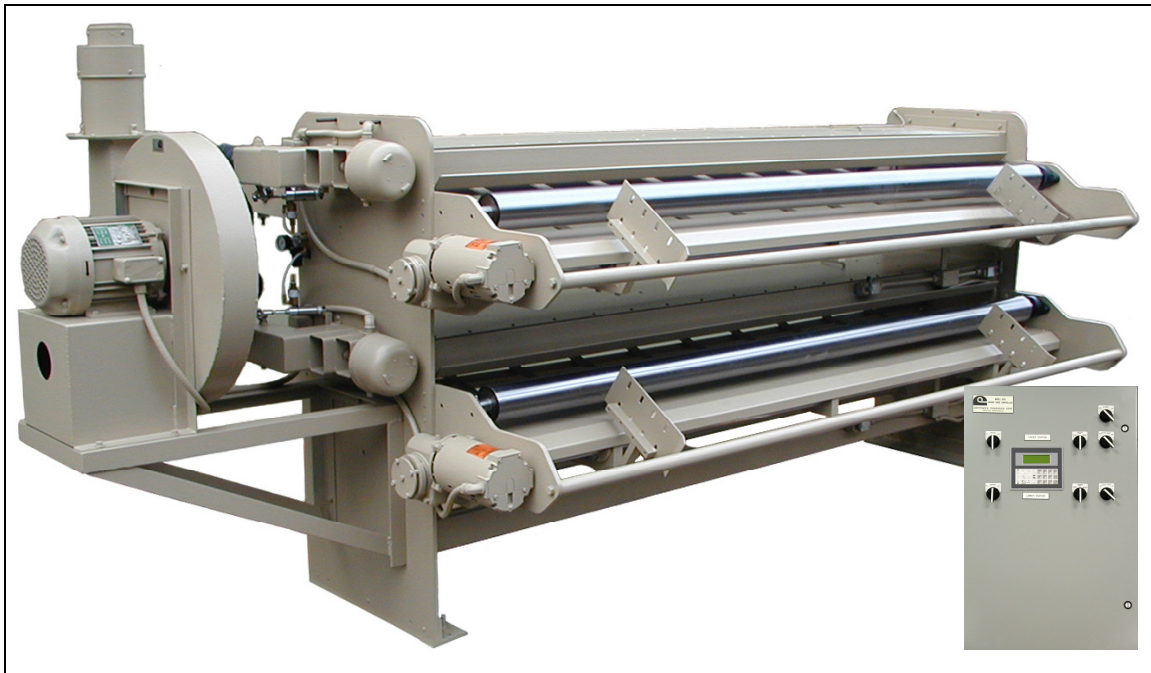




**CRITTENDEN CONVERSION CORPORATION**  
MOSES LAKE, WASHINGTON

## **VACUUM BRIDGE GUIDE 2002**



## Table of Contents

System Overview.....	4
Before Start.....	7
SYSTEM SETUP.....	8
CHANGE SETTINGS.....	9
Vacuum adjustment procedure.....	10
Change Pulses before stop to slow speed.....	12
Demo Mode.....	13
Set all values to default.....	14
Disable Upper / Lower stations.....	15
BG 2002 Operation.....	16
Troubleshooting.....	23
PLC DIGITAL INPUTS.....	25
PLC ANALOG INPUTS.....	26
PLC DIGITAL OUTPUTS.....	26
ANALOG OUTPUTS.....	27
POWER BUDGET.....	28
Keys.....	29
SCREENS, Screen #1.....	31
Screen #2.....	32
Screen #3.....	33
Screen #4.....	35
Screen #5.....	37
Screen #6.....	38
Screen #7.....	39
Screen #8.....	40
Screen # 9.....	42
Screen #10.....	44
Screen #11.....	45
Screen #12.....	46
Screen #13.....	48
Screen #14.....	49
Screen #15.....	50
Screen #16.....	52
Screen #17.....	53
Screen #18.....	54
Screen #19.....	55
Screen #20.....	56
Screen #21.....	58
Screen #22.....	59
Screen #23.....	61
Screen #24.....	63
Screen #25.....	65
Screen #26.....	66
Screen # 27.....	67
Screen #28.....	68
Screen #29.....	69
Screen #30.....	70
Screen #31.....	71
Screen #32.....	73
Screen #33.....	74

Screen #34 .....	76
Screen #35 .....	78
Screen #36 .....	79
Screen #37 .....	80
Screen #38 .....	81
Screen #39 .....	83
Screen #40 .....	85
Screen #41 .....	87
Screen #42 .....	88
Screen #43 .....	90
Screen #44 .....	91
Screen #45 .....	92
Screen #46 .....	93
Screen #47 .....	94
Screen #48, #49, #50, #51 .....	95
HELP SCREENS .....	96
Screen #400, #403, #404, #405 .....	96
Screen #406, #407, #408, #410, #411 .....	97
Screen #413, #414, #415, #417, #419, #420, #425, #426 .....	98
Screen #427, #428, #431, #433 .....	100

## APPENDIX

### SCHEMATIC DIAGRAMS

- 1 BG2 CONTROL PANEL 3-PHASE SCHEMATIC
- 2 BG2 CONTROL PANEL 120VAC TO 24/12 VDC DISTRIBUTION
- 3 BG2 CONTROL PANEL PLC INPUTS MAIN MODULE
- 4 BG2 CONTROL PANEL VACUUM CONTROL SWITCHES SCHEMATIC
- 5 BG2 CONTROL PANEL EXTENSION MODULES INPUTS SCHEMATIC
- 6 BG2 CONTROL PANEL OUTPUTS SCHEMATIC  
Extension module EM 235-OKD22-0XA0 AI4/AO Configuration Switch  
Settings
- 7 BG2 CONTROL PANEL TERMINAL STRIP WIRING SCHEMATIC
- 8 BG2 CONTROL PANEL BOX#1 TERMINAL STRIP WIRING SCHEMATIC
- 9 BG2 BLOWER 3-PHASE SCHEMATIC
- 10 MODEL MAR 8RH-8 120 50/60 0.6 AMP (VACUUM MORE/LESS)
- 11 BG-2002 - Vacuum Unit
- 12 DC-DC CONVERTER 24VDC/12VDC-VR-2002/12/10

### ASSEMBLING DIAGRAMS

- 1 CONDUITS AND JUNCTION BOXES
- 2 CABLES
- 3 JUNCTION BOX #1
- 4 MANUAL MOVE REMOTE CONTROL BOX
- 5 JUNCTION BOX#3&#4&#5&#6
- 6 JUNCTION BOX#7&#8&#9&#10
- 7 JUNCTION BOX#11
- 8 JUNCTION BOX#12
- 9 BG2 CONTROL PANEL FRONT INSIDE WIRING

VARIABLE FREQUENCY DRIVE SM410 PARAMETER TABLE  
 OIT TROUBLESHOOTING  
 BG2 PARTS LIST

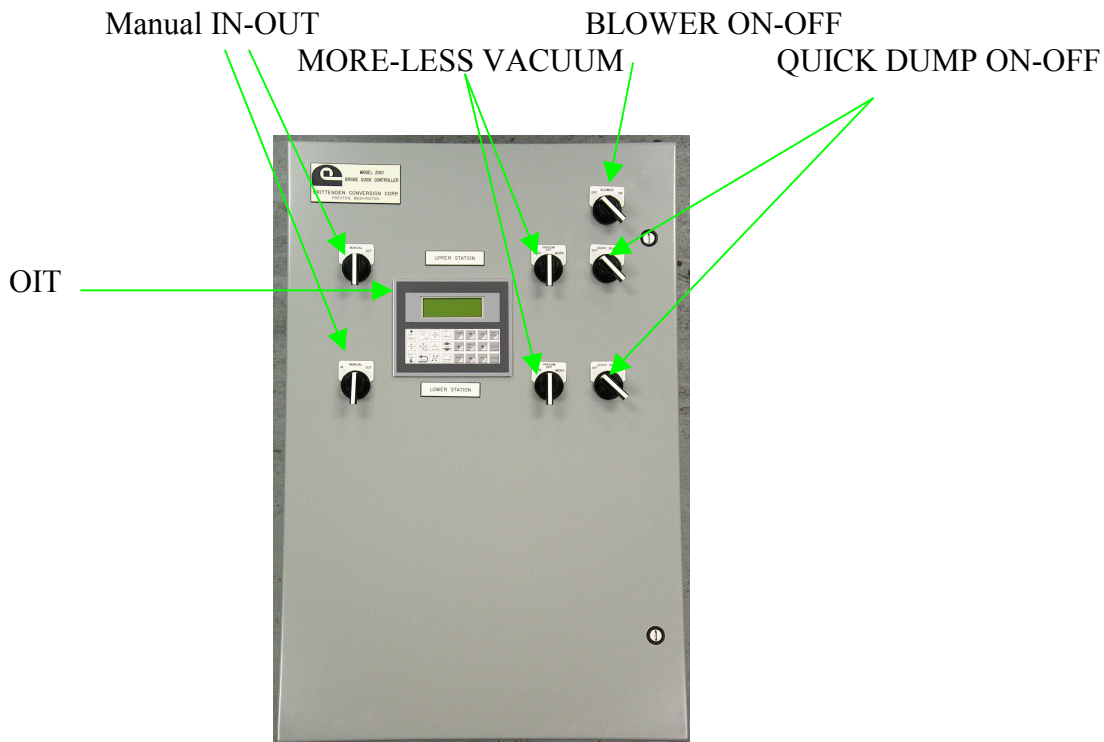
## System Overview

The bridge guide 2002 control system has been designed to provide automatic and manual opening width changing control for upper and lower bridge guide stations.

Guides are moved with two motors. Variable Frequency Drives (VFD) are used to drive the motors with two different speeds low and high. Positioning feedback information comes from the hollow shaft quadrature encoders, which send impulse sequences to the Programming Logic Controller (PLC). The PLC is used for processing these sequences and providing control signals to move and stop guides at desired positions.

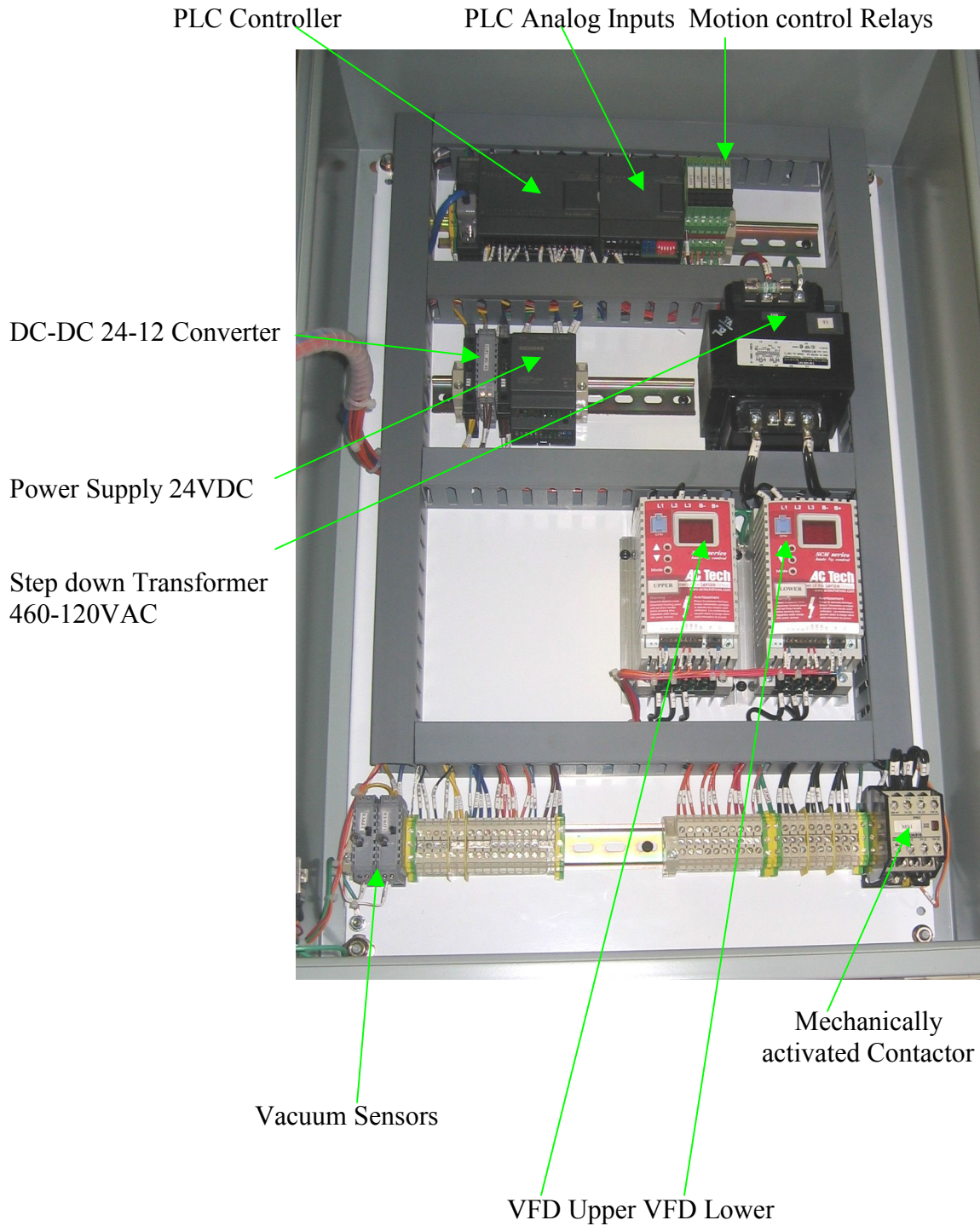
The blower unit with a 5 HP motor is used as a vacuum source for both vacuum chambers. Two MORE-LESS vacuum motors control the level of vacuum in the vacuum chambers. Two solenoids allow vacuum quick dump.

Operators can read and change vacuum and current position values for both stations from the Operator Interface Terminal (OIT) screen, guides may be moved using manual switches on the Main and Remote panel.



**Figure 1. Main Panel front view**

Two additional “Manual IN-OUT” switches locate on the opposite BLOWER side of the bridge to provide manual positioning control for the operator.



**Figure 2. Main Panel inside view.**

### Diagram of System Configuration

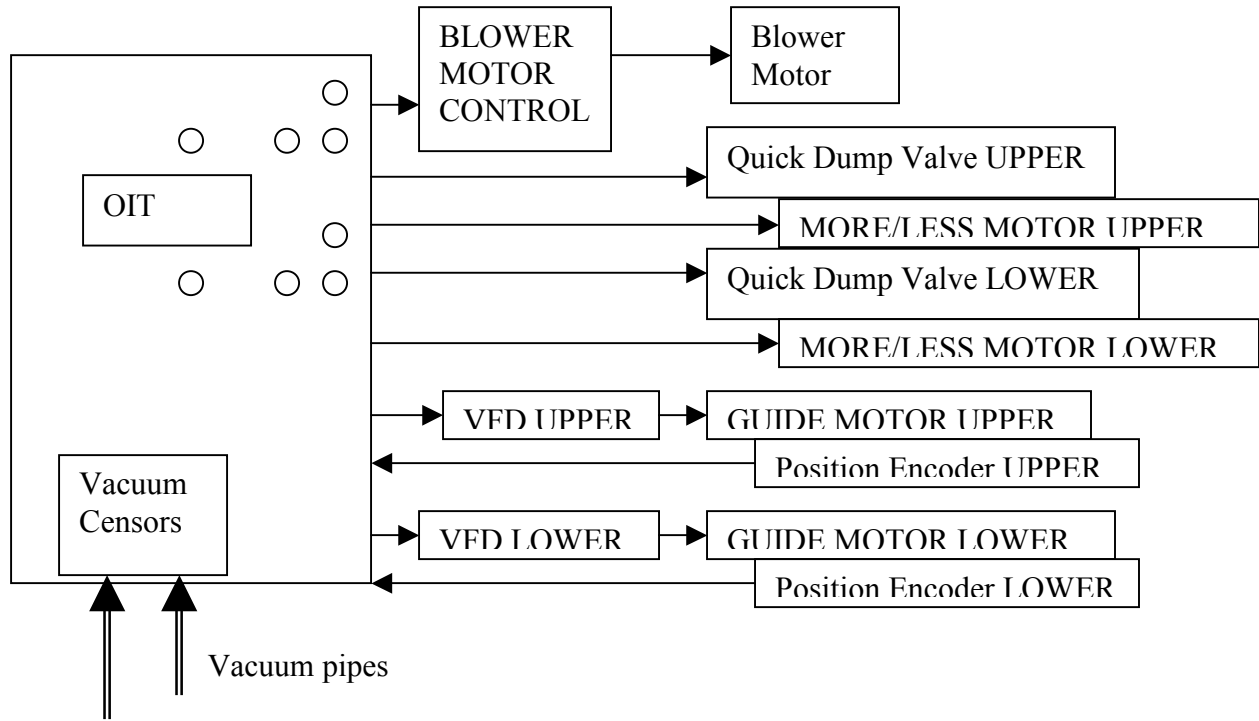


Figure 3. Diagram of System Configuration

## **Before Start**




1. Connect 3 phase 480VAC from the 15 AMP source to the inputs (L1, L2, L3) mechanically activated contactor in the Main panel. Run all high voltage wires separate from the low voltage and control wires.
2. Close the panel and make sure door is closed tightly.
3. After the introduction logo message appears on the Operator Interface Terminal (OIT) screen, turn “Blower ON/OFF” switch ON.
4. Check rotational direction of Blower. Swap the input two power wires if wrong.
5. Use “Manual IN/OUT” switches for all stations to move guides from the limit switches into the working area (Trip Arm is located between two limits). Check for the correct motion direction. Swap wires on the motors if wrong.
6. Guides must stop when they reach limit switches. Check limit switches (Normally Closed) and wiring if guides do not stop.

## SYSTEM SETUP


1. Make sure that Guides are locating in the working area (Trip Arm is located between limit switches). If not move them manually or use “Manual IN/OUT” switches.

**Attention!!! Do not try “Move home” until you make sure that the Guides are located between limit switches and Limit switches properly wired and tested.**


2. Push “Home” key. 

- On the message “Home?” Select “Yes” 
- To Stop Guide movement push “Stop” key  or 
- On message “Maximum width” enter measured width values for all stations (values can be **Metric** or **English**).

- Push Enter 

- Push Yes 
- On message “Minimum width” enter measured width values for all stations (values can be **Metric** or **English**).


- Push Enter 

- Push Yes 

3. System is ready. Numbers are now saved into the memory. Switching power OFF/ON does not change them. (It is possible to lose that setting if system remains OFF for more than 6 months.)




## Change settings

- 1) Push key 


On the screen you will see

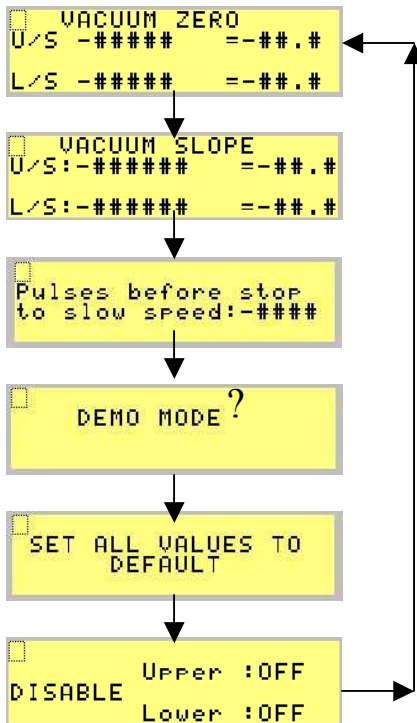


- 2) Push  - Yes


- 3) Enter password: **0000**

You will see first screen from the settings screen chain

Pushing  you can scroll between the available screens




## Vacuum adjustment procedure

- 1) Push key 

On the screen you will see



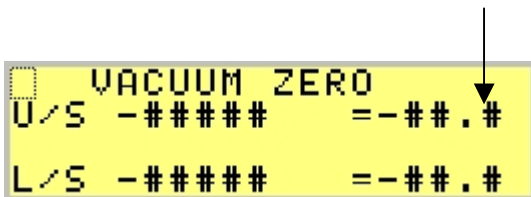
- 2) Push  - Yes



- 3) Enter password 0000

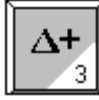
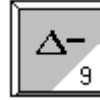
Turn off Blower.



On the screen you will see

Current Vacuum Readings for Upper/Lower




- 4) Use  and  to chose Upper, Middle or Lower station

- 5) Use  and  to Increase or Decrease Zero adjustment numbers

Or Push  and enter numbers, and then Push 

- 6) Change (~900) numbers until Current readings equal zero

- 7) Push 


Turn ON Blower and put paper on the vacuum chambers. Use vacuum meter gage to compare with readings.

On the screen you will see

- 8) 


- 9) Adjust slope similar with procedure described above (~1000). Use “More-Less” vacuum adjustments to set values in maximum (~15-20) and medium (~7-10).  
10) Return to the previous screen and repeat ZERO adjustment if it’s necessary.

## Change Pulses before stop to slow speed

- 1) Push key 


On the screen you will see

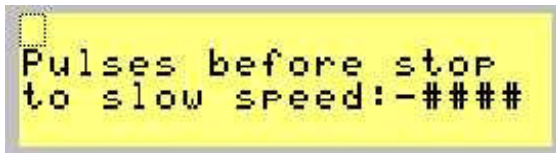


- 2) Push  - Yes



- 3) Enter password: **0000**

On the screen you will see first screen from the settings screen chain

- Push  until you will see



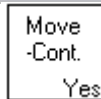
Screen.

- 4) Push  and enter number (~800), and then Push 

## DEMO Mode



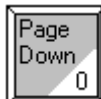
- 1) Push key
- On the screen you will see



- 2) Push

- 3) Enter password: **0000**

On the screen you will see first screen from the settings screen chain

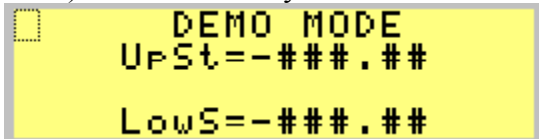


Push until you will see



- 4) Push

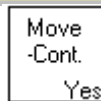
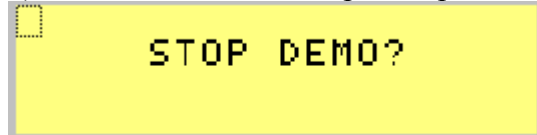
- 5) On the screen you will see and at the same time guides start motion out.



Numbers must change during motion both guides back and forward between limits.



- 6) Push



Push - Yes to stop demo or




to continue.

**Attention!!!**


**Do not try "Move home" until you make sure that the Guides are located between limit switches.**

## Set all values to default

- 1) Push key 

On the screen you will see




- 5) Push  - Yes

- 6) Enter password: **0000**


You will see first screen from the settings screen chain

- Push  until you will see




- Push  - Yes to set factory default settings values.

## Disable Upper / Lower stations

- 1) Push key 

On the screen you will see





- 2) Push  - Yes


- 3) Enter password: **0000**

You will see first screen from the settings screen chain

- 4) Push  until you will see



- 5) Use  and  to chose Upper or Lower station

- 7) Push  Toggle key to toggle between ON and OFF.

You can disable Upper and/or low station operation.

## BG 2002 Operation

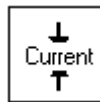


### 1. Get Help



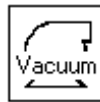
- Push and hold “Help” key
- Read Help screen

### 2. See current Width (values can be Metric or English).



- Push “Current” key

### 3. See current Vacuum readings.



- Push “Vacuum” key.

### 4. Enter New Upper station width(values can be Metric or English)..





- Push “New Upper” key;







- Push “Clear”,
- Enter numbers (for example: 44.5 > 4, 4, 5)





- Push "Enter" 
- Push "Yes" 




5. **Enter New Lower station width** (values can be **Metric** or **English**).

- Push "New Lower" key; 
- Push "Clear", 
- Enter numbers (for example: 44.5 > 4, 4, 5)
- Push "Enter" 
- Push "Yes" 









6. **Move to the new width.**

- Push "Move" 
- Check numbers on the screen "from 44.5 to 75.2"
- Push "Move" 


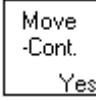
7. **Stop when moving.**

- Push "Stop" 
- On the message "Continue or Back" select "Move"  or "Back" 



## 8. Move Home.

- Push "Home" key. 
- On the message "Home?" Select "Yes"  or "NO" 
- You can stop any time to push "Stop" key. 
- On message "Maximum width" enter measured width values for all stations
- Push Enter 
- Push Yes 
- On message "Minimum width" enter measured width values for all stations. Push Enter 
- Push Yes 







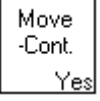

## 9. Abort motion and operation – Reset controller.

- Push "Abort"  or Turn power Off
- On message "Abort everything?" select "Yes". 

## 10. Change settings. (Vacuum scale and slope, distance before speed slow down, demo mode)

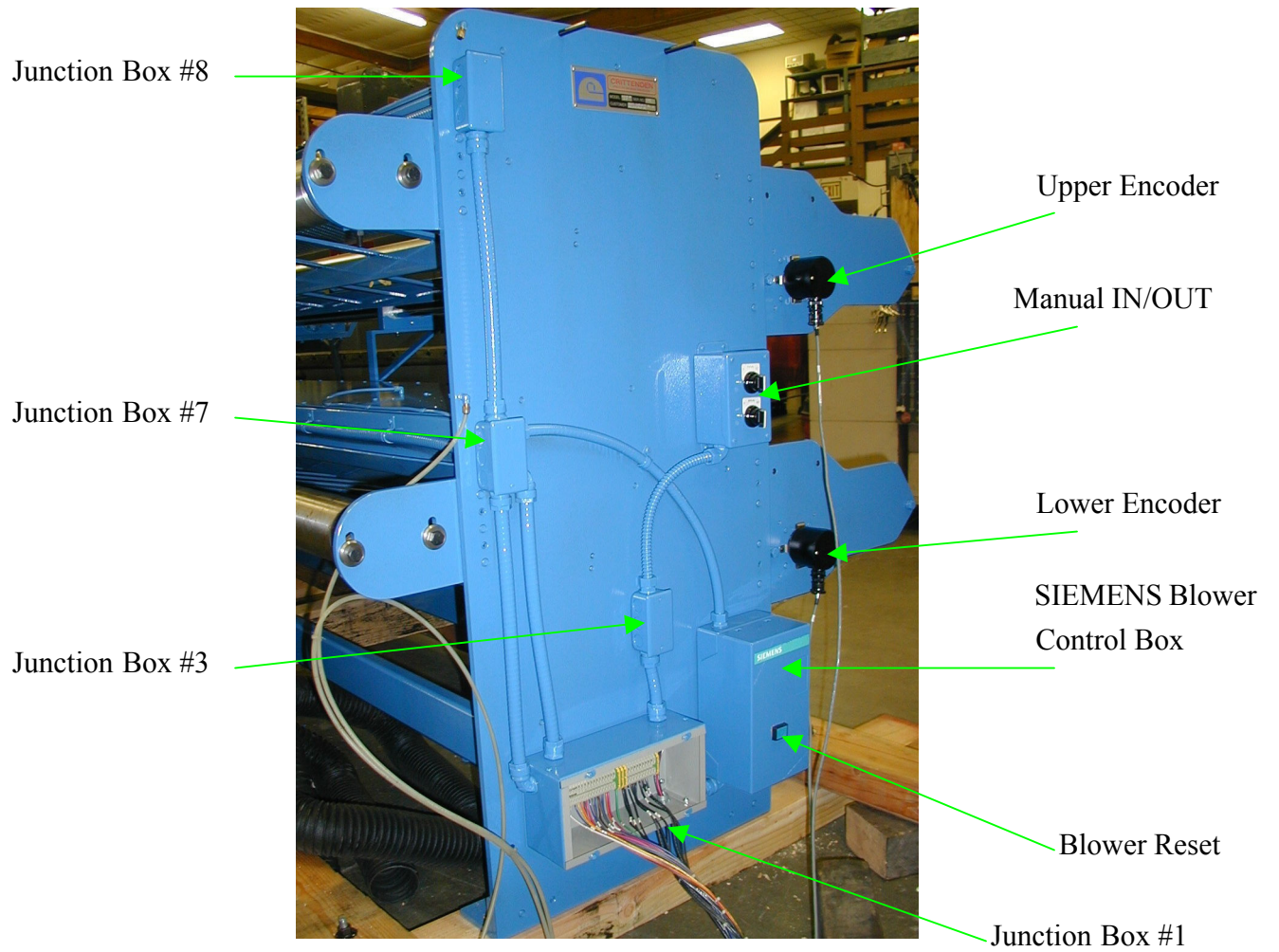
- Push "Settings" key 
- On the message "Are you sure to change settings?" select "Yes", 
- Enter password 0000,
- Change settings

## 11. Change Preset.

- Push "Preset" key. 
- Push "clear", 
- Enter new preset value.
- Push Enter 
- Push "Page Down" 
- On the message "Assign to new Upper Width?" Select "Yes"  or  
"No" 
- On message "Assign to new Lower Width?" select "Yes"  or "No"  

- ..... "Swap Upper new and Lower new"
- ..... "Assign to Upper new to lower new?"
- ..... "Assign to Lower new to Upper new?"

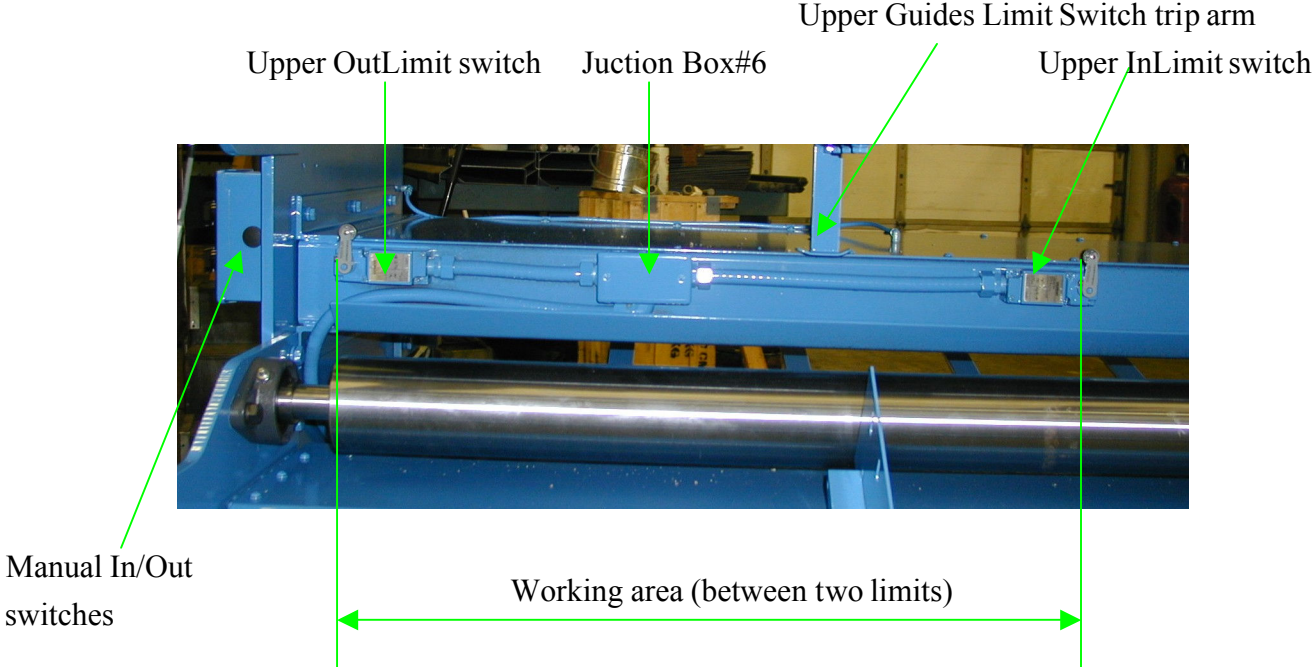
## 12. Stop Alarm

- Push "Alarm Acknowledgment" 

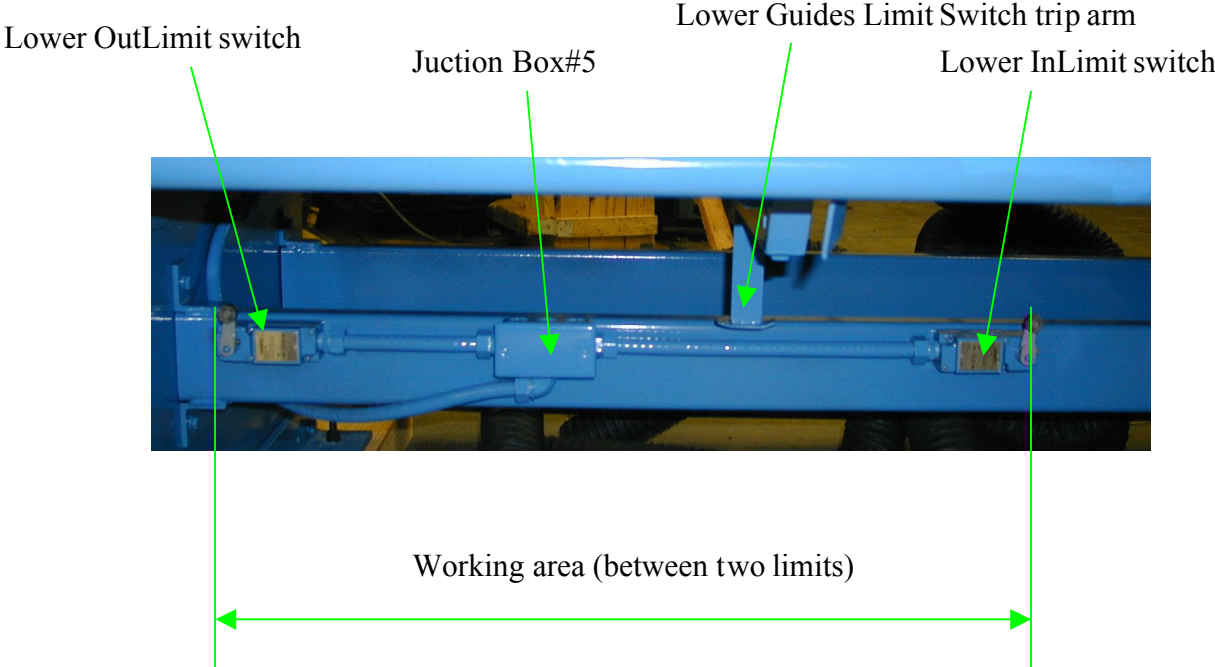


**Figure 4. Manual switches side.**

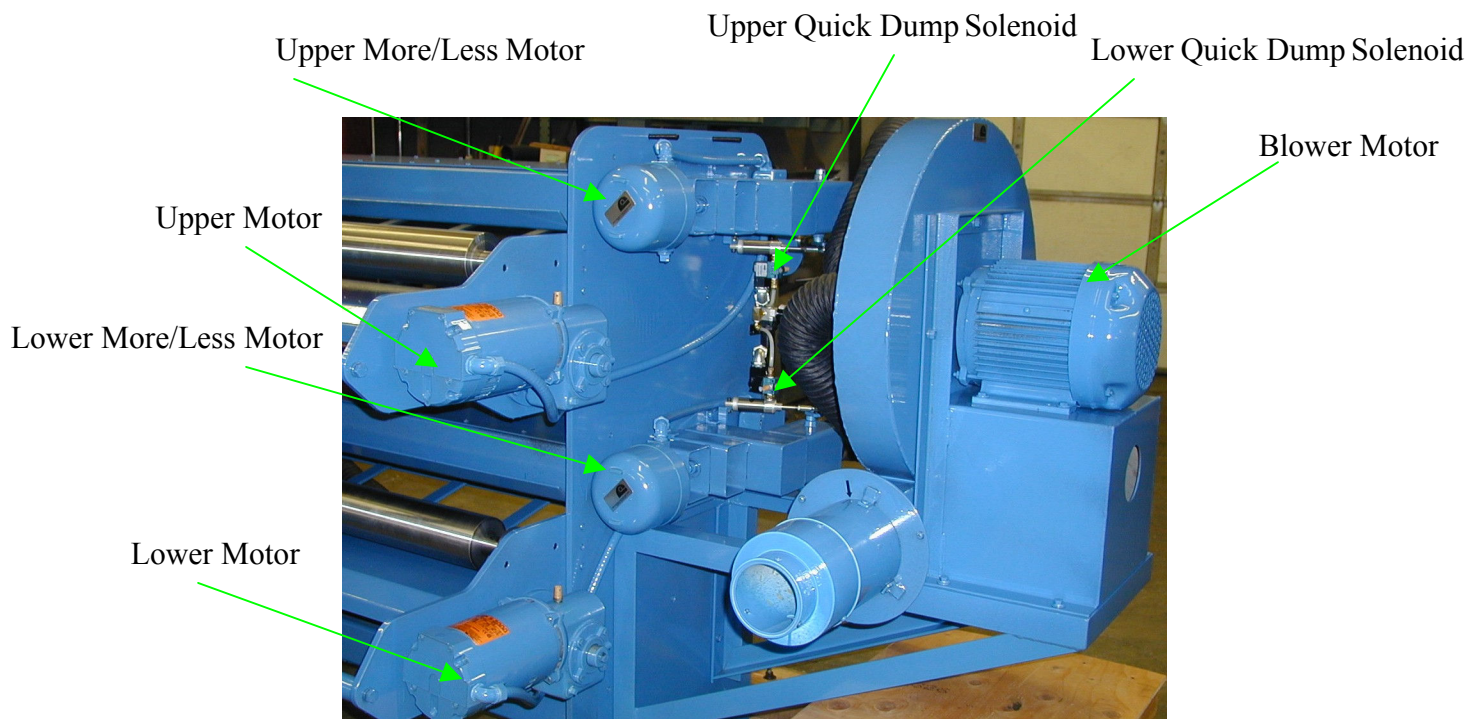
**Upper Station Limit Switches**



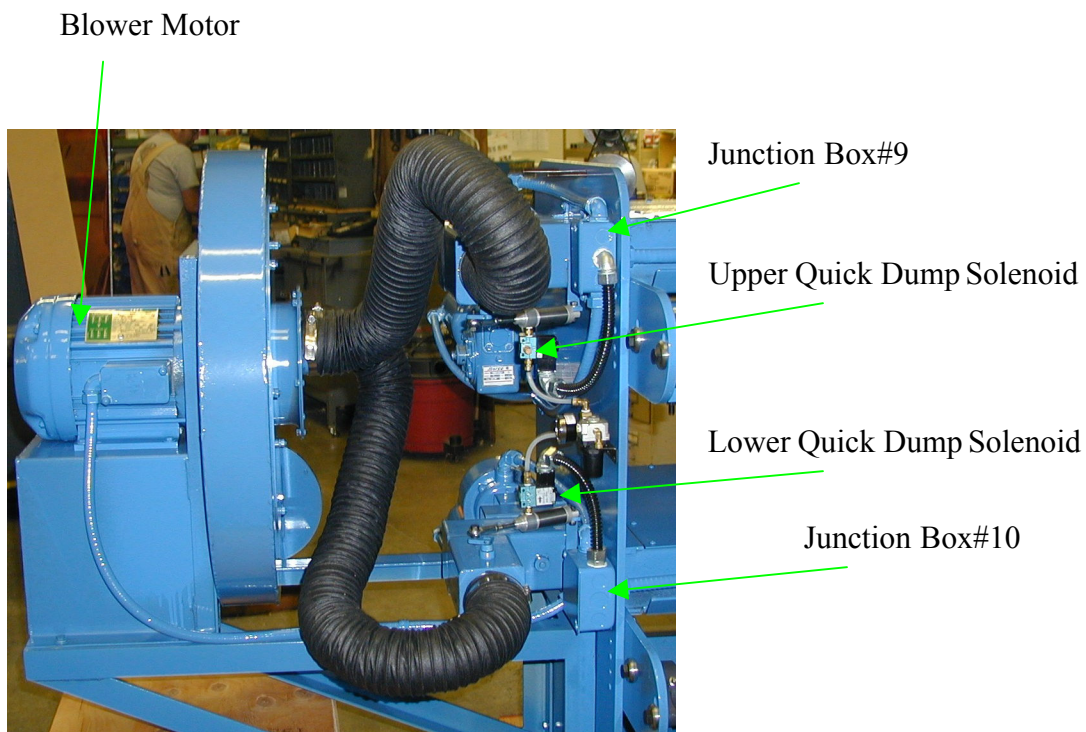
**Lower Station Limit Switches**



**Figure 5. Limit Switches**



**Figure 6. Blower side**



**Figure 7. Blower**



## Troubleshooting

ACTION	SCREEN/SYSTEM	POSSIBLE SOURCE OF PROBLEM	SOLUTION
System power on	The OIT screen is dark and -Manual IN and OUT does not work	No power 440VAC or 110 VAC No power 24 VDC.	Check the main panel door Is it completely closed? Check 440/110 Vac. Check the fuses in the main panel. Check 24 Vdc from the power supplies in the main panel.
System power on	The OIT screen is dark and -Manual IN and OUT does work	No power to OIT.	Check wires from terminal to the OIT in the main panel.
System power on	Error message on the OIT screen	Read message and follow recommendation on the screen and HELP screen.	Read message and follow recommendation on the screen
No motion	No messages	- Corresponding Control relays failed - VFD failed	Open main panel Power up manually and check error code from the VFD display. Check corresponding relays cause of the problem.
Checking vacuum	Readings “00” does not changing when using More or Less switch Blower working properly.	There is no paper. Vacuum pipe is not on vacuum sensor or bad sensor.	Check fuse or 12 DC on the sensor’s terminals. Install pipe or replace pipe or sensor
Start Blower	Blower starts but no vacuum	- No paper - Wrong rotational direction	- Put paper - Swap 2 input power wires
Start Blower	Blower does not start.	Overload protection relay turned off. No 460 VAC 3Phase power.	Push reset on the Blower control panel. Check 460 VAC 3 Phase power source.
Start More-Less	More-Less does not work	No power 110 VAC from the main panel or switch or “more less” motor does not work	Check power 110 VAC from main panel to the More-less switch and to the More-less motor

Start motion	Guides move into wrong direction	Wrong 3 phase power phasing	Swap two input 3 phase power wires on the corresponding motor.
Start motion	Numbers move in wrong direction	Wrong encoder phasing	Swap A and B channel encoder wires.
Start motion	Screen show motion screen but no any motion	- Check next width numbers for out limit values. - Check VFDs for possible errors	- Reenter correct next width -Open main panel. Power up and check for error messages on VFDs.
Start auto motion	Guides move and stop but does not reach the destination point (about an inch). Manual switches do not work.	Over torque on one of the station.	Eliminate source of over torque. Decrease max speed.(VFD parameter P31) Increase slow speed. (VFD parameter P32)



## PLC DIGITAL INPUTS

INPUTS	Device	Wires #	PLC ADDRESS
Upper station Positioning Encoder Pulses	Upper Encoder Ch A Ch B	A B	I0.0 I0.1
Upper station Manual IN	Switch Upper Manual In/Out	E	I0.2
Lower station Positioning Encoder Pulses	Lower Encoder Ch A Ch B	C D	I0.3 I0.4
Upper station Manual OUT	Switch Upper Manual In/Out	2	I1.4
Lower station Manual IN	Switch Lower Manual In/Out	3	I1.3
Lower station Manual OUT	Switch Lower Manual In/Out	4	I1.5
Upper station LIMIT switch	Upper Limit switches	5	I1.2
Lower station LIMIT switch	Lower Limit switches	6	I0.5
Upper Drive Fault	VFD Upper	UF	I1.0
Lower Drive Fault	VFD Lower	LF	I1.1
N/U			I0.6
N/U			I0.7

### PLC ANALOG INPUTS

INPUTS	Device	Wires##	PLC ADRESS
Vacuum sensor Upper	Vacuum sensor UP/PLC Analog Inputs module	A+	AIW4
Vacuum sensor Lower	Vacuum sensor Low/PLC Analog Inputs module	B+	AIW6

### PLC DIGITAL OUTPUTS

OUTPUTS	Device	Wires #	PLC ADDRESS
<b>Upper move Out</b>	<b>Relay Uout/VFD Upper</b>	<b>UOUT</b>	<b>Q0.0</b>
Upper move IN	Relay Uin /VFD Upper	UIN	Q0.2
Upper slow motion	Relay Uslow/ VFD Upper	USL	Q0.4
<b>Lower move Out</b>	<b>Relay Lout/ VFD Lower</b>	<b>LOUT</b>	<b>Q0.1</b>
Lower move IN	Relay Lin/ VFD Lower	LIN	Q0.3
Lower slow motion	Relay Lslow VFD Lower	LSL	Q0.5

## ANALOG OUTPUTS

Outputs	Control	Device	Wires##	VOLTAGE
Upper more vacuum	Upper more/less switch	Upper more/less motor	7	110VAC
Upper less vacuum	Upper more/less switch	Upper more/less motor	8	110VAC
Lower more vacuum	Lower more/less switch	Lower more/less motor	9	110VAC
Lower less vacuum	Lower more/less switch	Lower more/less motor	10	110VAC
Upper Quick dump	Upper Quick dump switch	Upper quick dump valve	11	110VAC
Lower Quick dump	Lower Quick dump Switch	Lower quick dump valve	12	110VAC
Blower ON/OFF	Blower Switch ON/OFF	Blower contactor	13	110VAC

## POWER BUDGET

### Double Station

System power Budget		440VAC		15 Amp source
System requirements:	Units Number	Amps per unit	Total amps	
Transformer 440/110	1	0.73	0.73	
VFDives 1 hp 2.5 A ( 0.5 hp 1.4 A)	2	2.5(1.4)	5.0(2.8)	
Blower motor 5 hp 6.2 Amp 460VAC	1	6.2	6.2	
Total (A)=			11.93(9.73)	

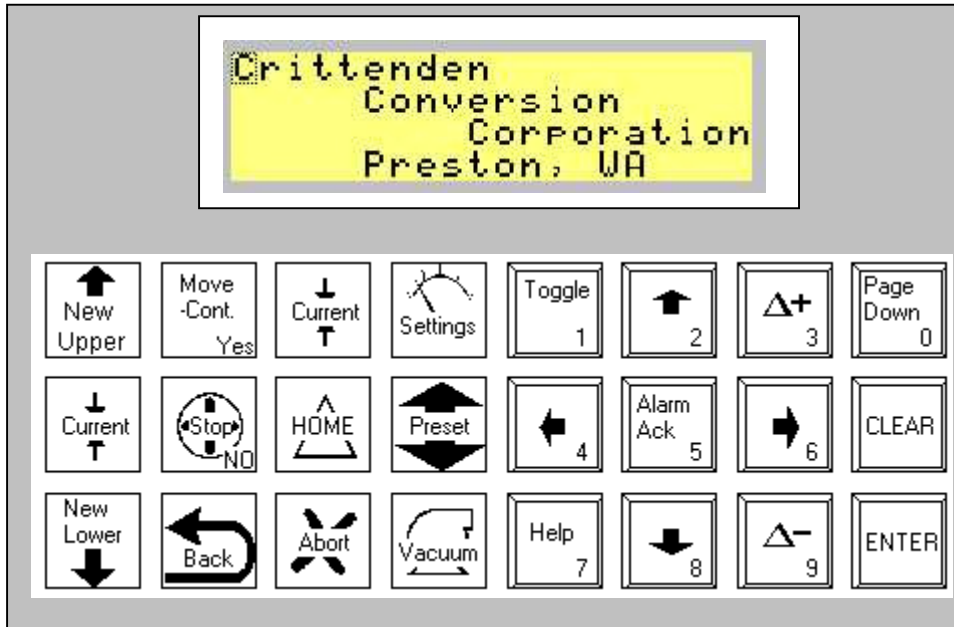
24VDC Power Budget		24VDC		
Power supply on CPU	<b>0.28 Amp</b>		No fuse	
System requirements	Units Number	Amps per unit	Total amps	
6 relays (outputs)	6	0.007	0.042	
Total (A)=			0.042	

Power supply External	<b>1.3 Amp</b>		Fuse inputs 1.5 AMP	
System requirements	Units Number	Amps per unit	Total amps	
OIT	1	0.1	0.1	
DC/DC 24/12VDC	1	0.15	0.15	
CPU 224	1	0.9	0.9	
Extension Module EM235	1	0.06	0.06	
Total (A)=			1.21	

110VAC				
Power supply	<b>3.33 Amp</b>		FUSE 3 AMP	
System requirements	Units Number	Amps per unit	Total amps	
110/24 power supply	1	0.48	0.48	
Blower starter	1	0.8	0.8	
Moreless vacuum motor	2	0.6	1.2	
Quick Dump solenoid	2	0.06	0.12	
Total(A)=			2.6	

12 VDC				
Power supply	<b>1 Amp</b>		Fuse 1 amps	
System requirements	Units Number	Amps per unit	Total amps	
Encoder	2	0.025	0.05	
12 inputs	12	0.004	0.048	
Vacuum sensor	2	0.01	0.02	
Total (A)=			0.118	

## Keys



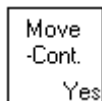
- Activate Home Procedure



- Enter NEW WIDTH for UPPER STATION



- Enter NEW WIDTH for LOWER STATION



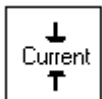
- Start Move or Continue or YES



- STOP MOTION or NO



- Move back to previous position



- Show current for UPPER and LOWER STATIONS



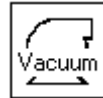
- ABORT all operation and reset controller



- Change settings (Password protected)



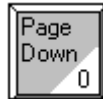
- Change preset and set preset



- Show vacuum values for UPPER and LOWER stations



- Get HELP on screen



- Scroll available screens



- Clear value



- Enter value



- 3 or Increment value



- 9 or Decrement value



- 5 or alarm acknowledgement



- 2 or cursor UP



- 4 or cursor LEFT



- 6 or cursor RIGHT



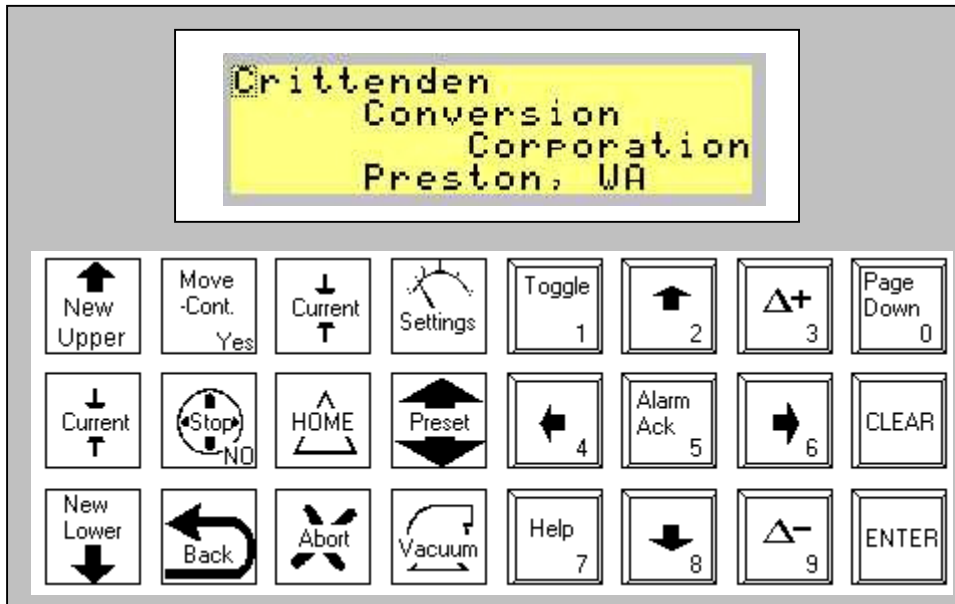
- 8 or cursor DOWN



- 1 or Toggle ON/OFF settings

# SCREENS

## Screen #1



### Screen Type:

Message

Start Up Screen

### Control Buttons.

SDF8



- OPEN screen #17 "Move Home?"

No password

### Chain screen.

Automatically go to the Screen #2 "Bridge Guide 2003 "

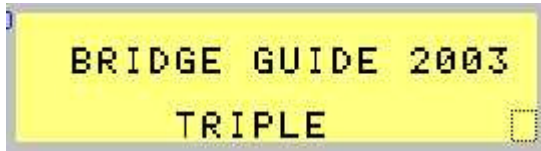
### Time showed.

2 sec

### Help screens.

Screen # 400

## Screen #2



**Screen Type:**

Message

**Control Buttons.**



- Open Screen #17 "Move Home?"

No password

**Chain screen.**

Automatically go to the Screen #3 "Information 800-755-7894"

**Time showed.**

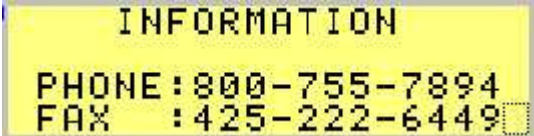
**5 sec**

**Help screens.**

Screen # 400



# Screen #3



**Screen Type:**

Message

**Control Buttons.**

**SDF1**

Screen #4 “Upper new Width?”  
No password

**SDF2**

Open Screen # 34 “Current Width”

**SDF3**

Screen # 23 “Low station new width”  
No password

**SDF4**

Open Screen # 34 “Current Width”  
No password

**SDF5**

Open Screen # 17 “HOME”

**SDF6**

Open Screen # 1 “Start UP”

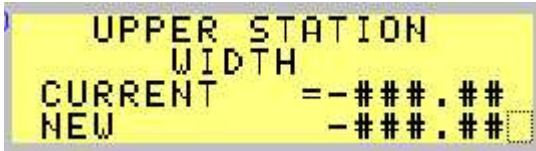


**SDF7**  
Open Screen # 34 "Current Width"



- Screen #17 "Move Home?"  
No password  
**Chain screen.**  
Automatically go to the Screen #22 "Current WIDTH"  
**Time showed.**  
**20 sec**  
**Help screens.**  
Screen # 400

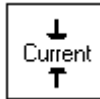
## Screen #4



### Screen Type:

Message

### Control Buttons.



**SDF2**

Open Screen # 34 "Current Width"

No password



**SDF3**

Screen # 23 "Low station new width"

No password



**SDF4**

Open Screen # 31 "Move from to "

No password



**SDF5**

Open Screen # 34 "Current width"



**SDF6**

Open Screen # Screen # 34 "Current width"



**SDF7**  
Open Screen # 34 "Current Width"



**SDF8**  
- Screen #17 "Move Home?"  
No password

**Chain screen.**  
Screen #34 "Current Width"  
**Time showed.**  
**60 sec**  
**Help screens.**  
Screen # 404

## Screen #5



**Screen Type:**  
Message Screen

**Sound**

**Beep**

**Control Buttons.**

**SDF1** A square button with a black border. Inside, there is a black upward-pointing arrow at the top, the word "New" in the middle, and the word "Upper" at the bottom.

Screen #4 "Upper new Width?"  
No password

**SDF7-** A square button with a black border. Inside, there is a black downward-pointing arrow at the top, the word "Current" in the middle, and a black upward-pointing arrow at the bottom.  
Open Screen # 34 "Current Width"

**SDF8** A square button with a black border. Inside, there is a black upward-pointing arrow at the top, the word "HOME" in the middle, and a black downward-pointing arrow at the bottom.

- Screen #17 "Move Home?"  
No password

**Chain screen.**  
#4 "New Upper Width"

**Time showed.**

**10 sec**

**Help screens.**

No

## Screen #6

```

MOTION      □←→--←→□
UpSt=-###.##
LoSt=-###.##

```

### Screen Type:

Message

### Control Buttons.



**SDF5**  
Stop motion



**SDF6**  
Back motion

### Chain screen.

No

### Time showed.

No

### Help screens.

#406

## Screen #7



**Screen Type:**

Message

**Control Buttons.**



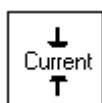
**SDF4**  
Continue Motion



**SDF5**  
Open Screen # 34 "Current Width"



**SDF6**  
Return to privies position



**SDF7**–  
Open Screen # 34 "Current Width"



**SDF8**

- Screen #17 "Move Home?"

**Chain screen.**

No

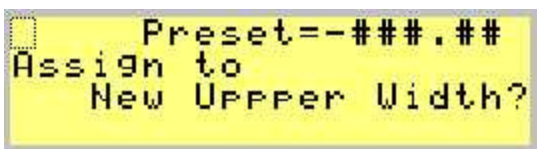
**Time showed.**

No

**Help screens.**

#407

## Screen #8



### Screen Type:

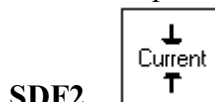
Message

### Control Buttons.



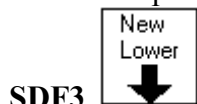
Screen #4 "Upper new Width?"

No password



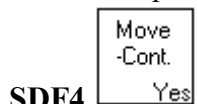
Open Screen # 34 "Current Width"

No password



Screen # 23 "Low station new width"

No password



Enter Preset

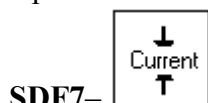
No password



Open Screen # 34 "Current Width"



Open Screen # 34 "Current Width"



Open Screen # 34 "Current Width"





- Screen #17 “Move Home?”

**Chain screen.**

Forward #55

Backward #33

**Time showed.**

No

**Help screens.**

No

## Screen # 9

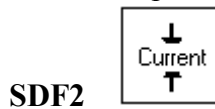


**Screen Type:**  
Message

### Control Buttons.



Screen #4 "Upper new Width?"  
No password



Open Screen # 34 "Current Width"  
No password



Screen # 23 "Low station new width"  
No password



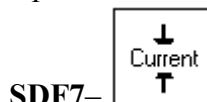
No password



Open Screen # 38 "Swap Width"



Open Screen # 34 "Current Width"



Open Screen # 34 "Current Width"



- Screen #17 "Move Home?"

**Chain screen.**

Forward #38

Backward #56

**Time showed.**

No

**Help screens.**

No

## Screen #10



**Screen Type:**

Message

**Sound .**

Beep.

**Control Buttons.**



Screen #17 "Move Home?"

No password

**Chain screen.**

Screen #17

**Time showed.**

255 sec

**Help screens.**

410

## Screen #11



**Screen Type:**

Message

**Sound .**

Beep.

**Control Buttons.**



SDF8

Screen #17 "Move Home?"

No password

**Chain screen.**

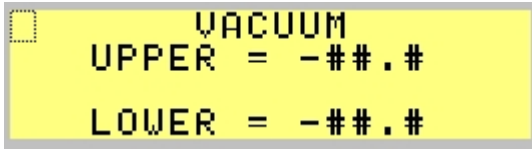
Screen #17

**Time showed.**

**Help screens.**

#411

## Screen #12



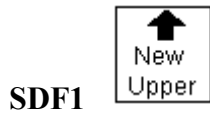
### Screen Type:

Message

Sound .

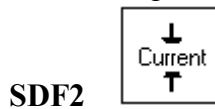
No

### Control Buttons.



Screen #4 "Upper new Width?"

No password



Open Screen # 34 "Current Width"

No password



Screen # 23 "Low station new width"

No password



Open Screen # 34 "Current Width"

No password



Open Screen # 34 "Current Width"

No password



Open Screen # 34 "Current Width"

No password



**SDF7**

Open Screen # 34 "Current Width"



**SDF8**

- Screen #17 "Move Home?"

No password

**Chain screen.**

Forward #34,

Backward #

**Time showed.**

**Help screens.**

## Screen #13



**Screen Type:**

Message

**Sound .**

Beep

**Control Buttons.**



SDF8

Screen #17 "Move Home?"

No password

**Chain screen.**

No

**Time showed.**

No

**Help screens.**

#413



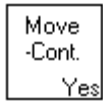
## Screen #14



**Screen Type:**  
Message

**Sound .**  
No

**Control Buttons.**



**SDF4**  
Screen #17 "Move Home?"  
No password



**SDF5**  
**DEMO continue**

**Chain screen.**

**Time showed.**  
sec

**Help screens.**  
#414

## Screen #15



**Screen Type:**  
Message

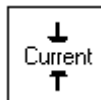
**Sound .**  
No

**Control Buttons.**



**SDF1**

Screen #4 "Upper new Width?"  
No password



**SDF2**

Open Screen # 34 "Current Width"  
No password



**SDF3**

Screen # 23 "Low station new width"  
No password



**SDF4**

**Start DEMO**

No password



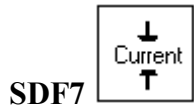
**SDF5**

Open Screen # 24 "Set all to default"  
No password



**SDF6**

Open Screen # 34 "Current Width"  
No password



**SDF7**  
Open Screen # 34 "Current Width"



**SDF8**  
- Screen #17 "Move Home?"  
No password  
**Chain screen.**  
FORWARD #24  
BACKWARD #45  
**Time showed 5 sec**  
**Help screens.415**

## Screen #16



**Screen Type:**  
Message

**Sound .**  
No

**Control Buttons.**



**STOP**

**Chain screen.**  
No

**Time showed.**

No

**Help screens.**

No

## Screen #17



**Screen Type:**

Message

**Sound .**

Beep

**Control Buttons.**



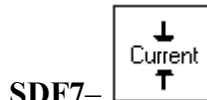
Move Home



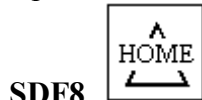
Open Screen # 34 "Current Width"



Open Screen # 34 "Current Width"



Open Screen # 34 "Current Width"



Screen #17 "Move Home?"

No password

**Chain screen.**

No

**Time showed.**

No

**Help screens.**

#417

## Screen #18



**Screen Type:**

Alarm

**Sound .**

Continuous Beep

**Control Buttons.**



**SDF8**

Screen #17 "Move Home?"

No password

**Chain screen.**

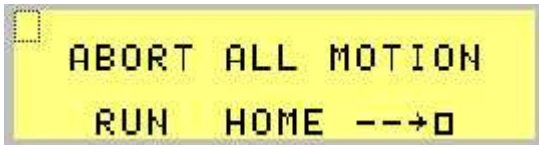
No

**Time showed.**

No

**Help screens.**

## Screen #19

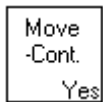


**Screen Type:**

Message

**Sound .**

Beep



**SDF4**

Screen #17 "Move Home?"

No password



**SDF5**

Open Screen # 34 "Current Width "

**Control Buttons.**



**SDF8**

Screen #17 "Move Home?"

No password

**Chain screen.**

17

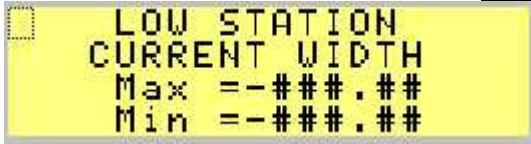
**Time showed.**

No

**Help screens.**

#419

## Screen #20



### Screen Type:

Message

Sound .

No

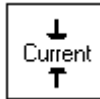
### Control Buttons.



SDF1

Screen #4 "Upper new Width?"

No password



SDF2

Open Screen # 34 "Current Width"

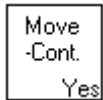
No password



SDF3

Screen # 23 "Low station new width"

No password



SDF4

Start DEMO

No password



SDF5

Open Screen # 24 "Set all to default"

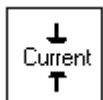
No password



SDF6

Open Screen # 34 "Current Width"

No password



SDF7

Open Screen # 34 "Current Width"





- Screen #17 "Move Home?"

**Chain screen.**

Forward #57

Backward #22

**Time showed.**

**5 sec**

**Help screens.**

#420

## Screen #21



**Screen Type:**

Message

**Sound .**

No

**Control Buttons.**



**SDF5**

**STOP**

**Chain screen.**

No

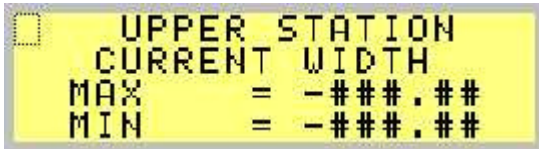
**Time showed.**

No

**Help screens.**

No

## Screen #22



### Screen Type:

Message

Sound .

No

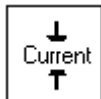
### Control Buttons.



SDF1

Screen #4 "Upper new Width?"

No password



SDF2

Open Screen # 34 "Current Width"

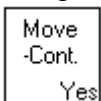
No password



SDF3

Screen # 23 "Low station new width"

No password



SDF4

Current width

No password



SDF5

Open Screen # 24 "Set all to default"

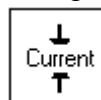
No password



SDF6

Open Screen # 34 "Current Width"

No password



SDF7

Open Screen # 34 "Current Width"



- Screen #17 "Move Home?"

**Chain screen.**

**Forward #20**

**Backward #3**

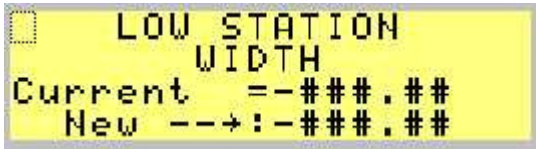
**Time showed.**

**5 sec**

**Help screens.**

**#420**

## Screen #23



### Screen Type:

Message

Sound .

No

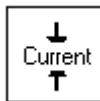
### Control Buttons.



SDF1

Screen #4 "Upper new Width?"

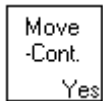
No password



SDF2

Open Screen # 34 "Current Width"

No password



SDF4

### Start motion

No password



SDF5

Open Screen # 24 "Set all to default"

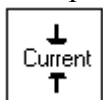
No password



SDF6

Open Screen # 34 "Current Width"

No password



SDF7

Open Screen # 34 "Current Width"

SDF8



- Screen #17 "Move Home?"

**Chain screen.**

34

**Time showed.**

No

**Help screens.**

404

## Screen #24



### Screen Type:

Message

Sound .

No

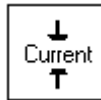
### Control Buttons.



**SDF1**

Screen #4 "Upper new Width?"

No password



**SDF2**

Open Screen # 34 "Current Width"

No password



**SDF3**

Screen # 23 "Low station new width"

No password



**SDF4**

Start set default values

No password



**SDF5**

Open Screen # 24 "Set all to default"

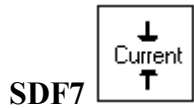
No password



**SDF6**

Open Screen # 34 "Current Width"

No password



**SDF7**  
Open Screen # 34 "Current Width"



**SDF8**  
- Screen #17 "Move Home?"  
**Chain screen.**  
**Forward #47**  
**Backward #15**

**Time showed.**  
**20 sec**  
**Help screens.**  
**#403**



## Screen #25



**Screen Type:**

Message

**Sound .**

**Beep**

**Control Buttons.**



**SDF8**

Screen #17 "Move Home?"

No password

**Chain screen.**

17

**Time showed.**

No

**Help screens.**

#425

## Screen #26

```

 HOME MinWidth
MEASURE Up/S:-###.##
AND
ENTER Low/S:-###.##

```

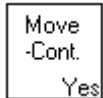
**Screen Type:**

Message

**Sound .**

Beep

**Control Buttons.**



**SDF4**

Continue

No password



**SDF8**

Screen #17 "Move Home?"

No password

**Chain screen.**

No

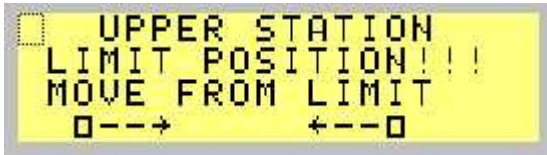
**Time showed.**

No

**Help screens.**

#426

## Screen # 27



**Screen Type:**

Message

**Sound .**

NO

**Control Buttons.**

**Chain screen.**

**Time showed.**

No

**Help screens.**

427

## Screen #28



**Screen Type:**

Message

**Sound .**

Beep

**Control Buttons.**

**Chain screen.**

**Time showed.**

**No**

**Help screens.**

428

## Screen #29



**Screen Type:**  
Message

**Sound .**  
NO

**Control Buttons.**

**Chain screen.**

**Time showed.**

**No**

**Help screens.**

427

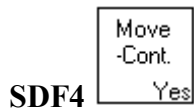
## Screen #30



**Screen Type:**  
Message

**Sound .**  
NO

**Control Buttons.**



Move

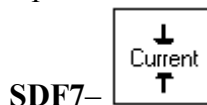
No password



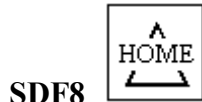
Open Screen # 34 "Current Width"



Open Screen # 34 "Current Width"



Open Screen # 34 "Current Width"



Screen #17 "Move Home?"

No password

**Chain screen.**

NO

**Time showed.**

No

**Help screens. 405**

## Screen #31

```
MOVE FROM → TO?  
U/S=-###.## :-###.##  
L/S=-###.## :-###.##
```

**Screen Type:**

Message

**Sound .**

NO

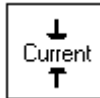
**Control Buttons.**



**SDF1**

Screen #4 "Upper new Width?"

No password



**SDF2**

Open Screen # 34 "Current Width"

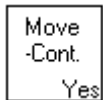
No password



**SDF3**

Screen # 23 "Low station new width"

No password



**SDF4**

**Move**

No password



**SDF5**

Open Screen # 24 "Set all to default"

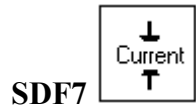
No password



**SDF6**

Open Screen # 34 "Current Width"

No password



**SDF7**  
Open Screen # 34 "Current Width"



**SDF8**  
- Screen #17 "Move Home?"

**Chain screen.**

34

**Time showed.**

No

**Help screens.**

431



## Screen #32



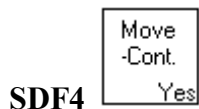
### Screen Type:

Message

### Sound .

NO

### Control Buttons.



Yes change settings

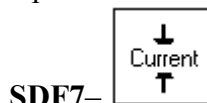
No password



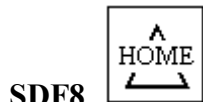
Open Screen # 34 "Current Width"



Open Screen # 34 "Current Width"



Open Screen # 34 "Current Width"



Screen #17 "Move Home?"

No password

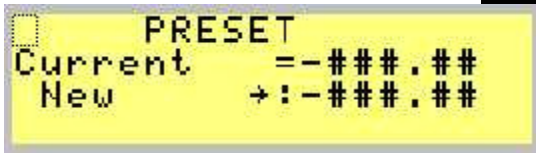
### Chain screen.

### Time showed.

No

### Help screens.

## Screen #33



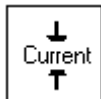
**Screen Type:**  
Message

**Sound .**  
NO

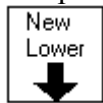
**Control Buttons.**



**SDF1**  
Screen #4 "Upper new Width?"  
No password



**SDF2**  
Open Screen # 34 "Current Width"  
No password



**SDF3**  
Screen # 23 "Low station new width"  
No password



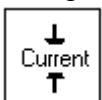
**SDF4**  
Continue  
No password



**SDF5**  
Open Screen # 24 "Set all to default"  
No password



**SDF6**  
Open Screen # 34 "Current Width"  
No password



**SDF7**

Open Screen # 34 "Current Width"



- Screen #17 "Move Home?"

**Forward #8**

**Backward #40**

**Time showed.**

**No**

**Help screens.**

433

## Screen #34

```

CURRENT WIDTH
UPPER      =-###.##
LOWER      =-###.##

```

### Screen Type:

Message

### Sound .

NO

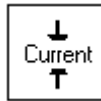
### Control Buttons.



SDF1

Screen #4 "Upper new Width?"

No password



SDF2

Open Screen # 34 "Current Width"

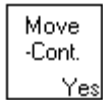
No password



SDF3

Screen # 23 "Low station new width"

No password



SDF4

Move to next widths

No password



SDF5

Open Screen # 24 "Set all to default"

No password



SDF6

Open Screen # 34 "Current Width"

No password



- Screen #17 "Move Home?"

**Chain screen.**

Forawrd #12

Backward #12

**Time showed.**

**Help screens.**

408

## Screen #35

```
□ HOME MaxWidth
Measure U/S:-###.##
and ---->
Enter L/S:-###.##
```

### Screen Type:

Message

### Sound .

Beep

### Control Buttons.



SDF4

YES continue after Max width entered



SDF5

Open Screen # 24 "Set all to default"

No password



SDF6

Open Screen # 34 "Current Width"

No password



SDF8

- Screen #17 "Move Home?"

### Chain screen.

NO

### Time showed.

NO

### Help screens.

NO

## Screen #36



### Screen Type:

Alarm

1 sec

### Sound .

Beep.

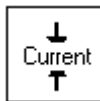
### Control Buttons.



### SDF1

Screen #4 "Upper new Width?"

No password



### SDF2

Open Screen # 34 "Current Width"

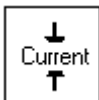
No password



### SDF6

Open Screen # 34 "Current Width"

No password



### SDF7

Open Screen # 34 "Current Width"



### SDF8

- Screen #17 "Move Home?"

### Chain screen.

Screen #23

### Time showed.

60 sec

### Help screens.

#

## Screen #37



**Screen Type:**

Alarm

1 sec

**Sound .**

Beep.

**Control Buttons.**



**SDF8**

Screen #17 "Move Home?"

No password

**Chain screen.**

**Time showed.**

60 sec

**Help screens.**

#



## Screen #38



### Screen Type:

Message

### Sound .

NO

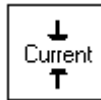
### Control Buttons.



#### SDF1

Screen #4 "Upper new Width?"

No password



#### SDF2

Open Screen # 34 "Current Width"

No password



#### SDF3

Screen # 23 "Low station new width"

No password



#### SDF4

Yes Swap

No password



#### SDF5

Open Screen # 24 "Set all to default"

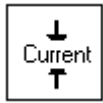
No password



#### SDF6

Open Screen # 34 "Current Width"

No password



**SDF7**

Open Screen # 34 "Current Width"



**SDF8**

- Screen #17 "Move Home?"

**Chain screen.**

**Forward #39**

**Backward #9**

**Time showed.**

**No**

**Help screens.**

## Screen #39



### Screen Type:

Message

### Sound .

NO

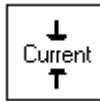
### Control Buttons.



**SDF1**

Screen #4 "Upper new Width?"

No password



**SDF2**

Open Screen # 34 "Current Width"

No password



**SDF3**

Screen # 23 "Low station new width"

No password



**SDF4**

Yes Assign

No password



**SDF5**

Open Screen # 24 "Set all to default"

No password



**SDF6**

Open Screen # 34 "Current Width"

No password



**SDF7**  
Open Screen # 34 "Current Width"



**SDF8**  
- Screen #17 "Move Home?"

**Chain screen.**

Forward #40

Backward #38

**Time showed.**

**No**

**Help screens.**

## Screen #40



### Screen Type:

Message

### Sound .

NO

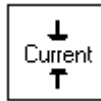
### Control Buttons.



#### SDF1

Screen #4 "Upper new Width?"

No password



#### SDF2

Open Screen # 34 "Current Width"

No password



#### SDF3

Screen # 23 "Low station new width"

No password



#### SDF4

Yes Assign

No password



#### SDF5

Open Screen # 24 "Set all to default"

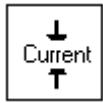
No password



#### SDF6

Open Screen # 34 "Current Width"

No password



**SDF7**

Open Screen # 34 "Current Width"



**SDF8**

- Screen #17 "Move Home?"

**Chain screen.**

Forward #33

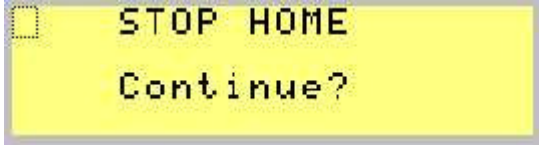
Backward #39

**Time showed.**

**No**

**Help screens.**

## Screen #41



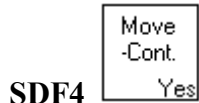
**Screen Type:**

Message

**Sound .**

NO

**Control Buttons.**



Yes

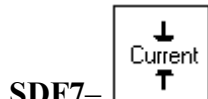
No password



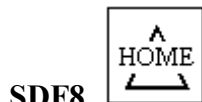
Open Screen # 34



Open Screen # 17



Open Screen # 34 "Current Width"



Screen #17 "Move Home?"

No password

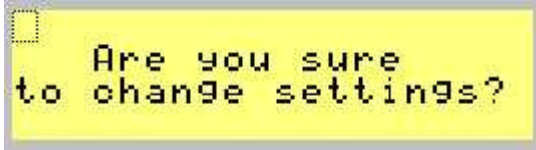
**Chain screen.**

**Time showed.**

No

**Help screens.**

## Screen #42



### Screen Type:

Message

Sound .

NO

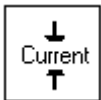
### Control Buttons.



**SDF1**

Screen #4 "Upper new Width?"

No password



**SDF2**

Open Screen # 34 "Current Width"

No password



**SDF3**

Screen # 23 "Low station new width"

No password



**SDF4**

Vacuum #43

No password



**SDF5**

Open Screen # 24 "Set all to default"

No password

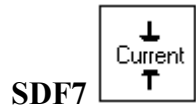


**SDF6**

Open Screen # 34 "Current Width"

No password





**SDF7**  
Open Screen # 34 "Current Width"



**SDF8**  
- Screen #17 "Move Home?"

**Chain screen.**

#34

**Time showed.**

No

**Help screens.**

## Screen #43

```

VACUUM ZERO
U/S -##### =-##.#
L/S -##### =-##.#

```

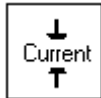
**Screen Type:**  
Message

**Sound .**  
NO

**Control Buttons.**



**SDF6**  
Open Screen # 34



**SDF7-** Open Screen # 34 "Current Width"



**SDF8**  
Screen #17 "Move Home?"  
No password

**Chain screen.**  
Forward #44  
Backward #47

**Time showed.**

No

**Help screens.**

## Screen #44

```

VACUUM SLOPE
U/S:-##### =-##.#
L/S:-##### =-##.#

```

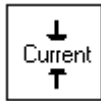
**Screen Type:**  
Message

**Sound .**  
NO

**Control Buttons.**



**SDF6**  
Open Screen # 34



**SDF7-** Open Screen # 34 "Current Width"



**SDF8**  
Screen #17 "Move Home?"  
No password

**Chain screen.**  
Forward #45  
Backward #43

**Time showed.**  
No  
**Help screens.**

## Screen #45



**Screen Type:**

Message

**Sound .**

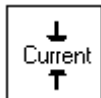
NO

**Control Buttons.**



**SDF6**

Open Screen # 34



**SDF7-**

Open Screen # 34 "Current Width"



**SDF8**

Screen #17 "Move Home?"

No password

**Chain screen.**

Forward #15

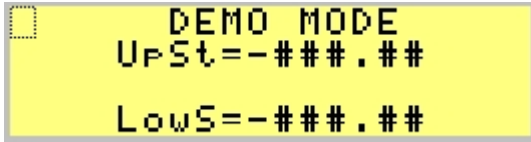
Backward #44

**Time showed.**

No

**Help screens.**

## Screen #46



**Screen Type:**

Message

**Sound .**

NO

**Control Buttons.**



**STOP DEMO**

**Chain screen.**

**Time showed.**

No

**Help screens.**

## Screen #47



**Screen Type:**  
Message

**Sound .**  
NO

**Control Buttons.**



- 2 or cursor UP



- 8 or cursor DOWN



- 1 or Toggle ON/OFF settings



**SDF6**  
Open Screen # 34



**SDF7-** Open Screen # 34 "Current Width"



**SDF8**  
Screen #17 "Move Home?"  
No password

**Chain screen.**  
Forward #43  
Backward #0

**Time showed.**  
10 sec  
**Help screens.**

## Screen #48,49



**Screen Type:**

Message

**Sound .**

3 beps

**Control Buttons.**

**Chain screen.**

Forward #43

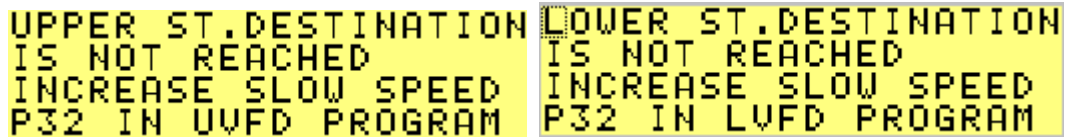
Backward #0

**Time showed.**

10 sec

**Help screens.**

## Screen #50,51



**Screen Type:**

Alarm.

**Sound.**

3 beps

**Control Buttons.**

Alarm Ack

**Chain screen.**

**Time showed.**

Help screens.

## HELP SCREENS

### Screen #400

Screen Type:

Help

```
Push "Home" to start  
INFORMATION  
PHONE:800-755-78947
```

### Screen#403

Screen Type:

Help

```
"YES"-Set all to  
Factory Default
```

### Screen #404

Screen Type:

Help

```
Push "Clear" enter New  
width and "Enter"  
Use number keys or  
decrement/increment
```

### Screen #405

Screen Type:

Help

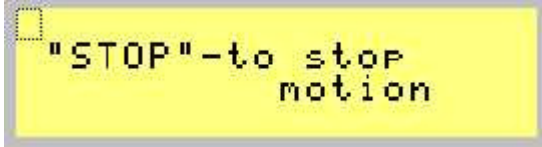
```
"YES"-MoveBack  
"Other Choices"
```



## Screen #406

Screen Type:

Help



## Screen #407

Screen Type:

Help



## Screen #408

Screen Type:

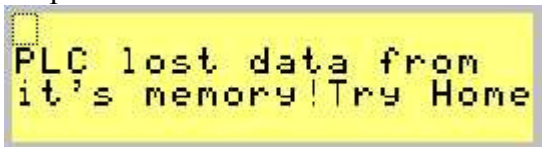
Help



## Screen #410

Screen Type:

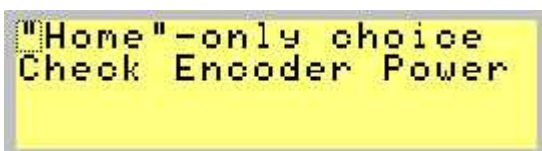
Help



## Screen #411

Screen Type:

Help



## Screen #413

Screen Type:

Help

```
Check Drive Error  
Power-Off-Start-Home
```

## Screen #414

Screen Type:

Help

```
"Yes"-Stop "DEMO"  
"No"-Continue "DEMO"
```

## Screen #415

Screen Type:

Help

```
"Yes"-Start "DEMO"
```

## Screen #417

Screen Type:

Help

```
"YES"-StartHome  
"Other choices"
```

## Screen #419

Screen Type:

Help

```
After "Abort" Run  
"HOME" to SetUp Sys.
```

## Screen #420

Screen Type:

Help

```
To change Run Home
```

## Screen #425

Screen Type:

Help

```
PLC lost data from  
it's memory Run Home
```

## Screen #426

Screen Type:

Help

```
Measure and Enter  
correct values
```

## Screen #427

Screen Type:

Help

```
Move guides from  
limit position
```

## Screen #428

Screen Type:

Help

```
Open box and check  
error code on drive
```

## Screen #431

Screen Type:

Help

```
Check values before  
"yes"-to start move
```

## Screen #433

Screen Type:

Help

```
"Yes"-NewPRST+CRNT  
See other Pages+
```

## **APPENDIX**

### ***SCHEMATIC DIAGRAMS***

- 1 BG2 CONTROL PANEL 3-PHASE SCHEMATIC
- 2 BG2 CONTROL PANEL 120VAC TO 24/12 VDC DISTRIBUTION
- 3 BG2 CONTROL PANEL PLC INPUTS MAIN MODULE
- 4 BG2 CONTROL PANEL VACUUM CONTROL SWITCHES SCHEMATIC
- 5 BG2 CONTROL PANEL EXTENSION MODULES INPUTS SCHEMATIC
- 6 BG2 CONTROL PANEL OUTPUTS SCHEMATIC  
Extension module EM 235-OKD22-0XA0 AI4/AO Configuration Switch Settings
- 7 BG2 CONTROL PANEL TERMINAL STRIP WIRING SCHEMATIC
- 8 BG2 CONTROL PANEL BOX#1 TERMINAL STRIP WIRING SCHEMATIC
- 9 BG2 BLOWER 3-PHASE SCHEMATIC
- 10 MODEL MAR 8RH-8 120 50/60 0.6 AMP (VACUUM MORE/LESS)
- 11 BG2-2003 - Vacuum Unit
- 12 DC-DC CONVERTER 24VDC/12VDC-VR-2002/12/10

### ***ASSEMBLING DIAGRAMS***

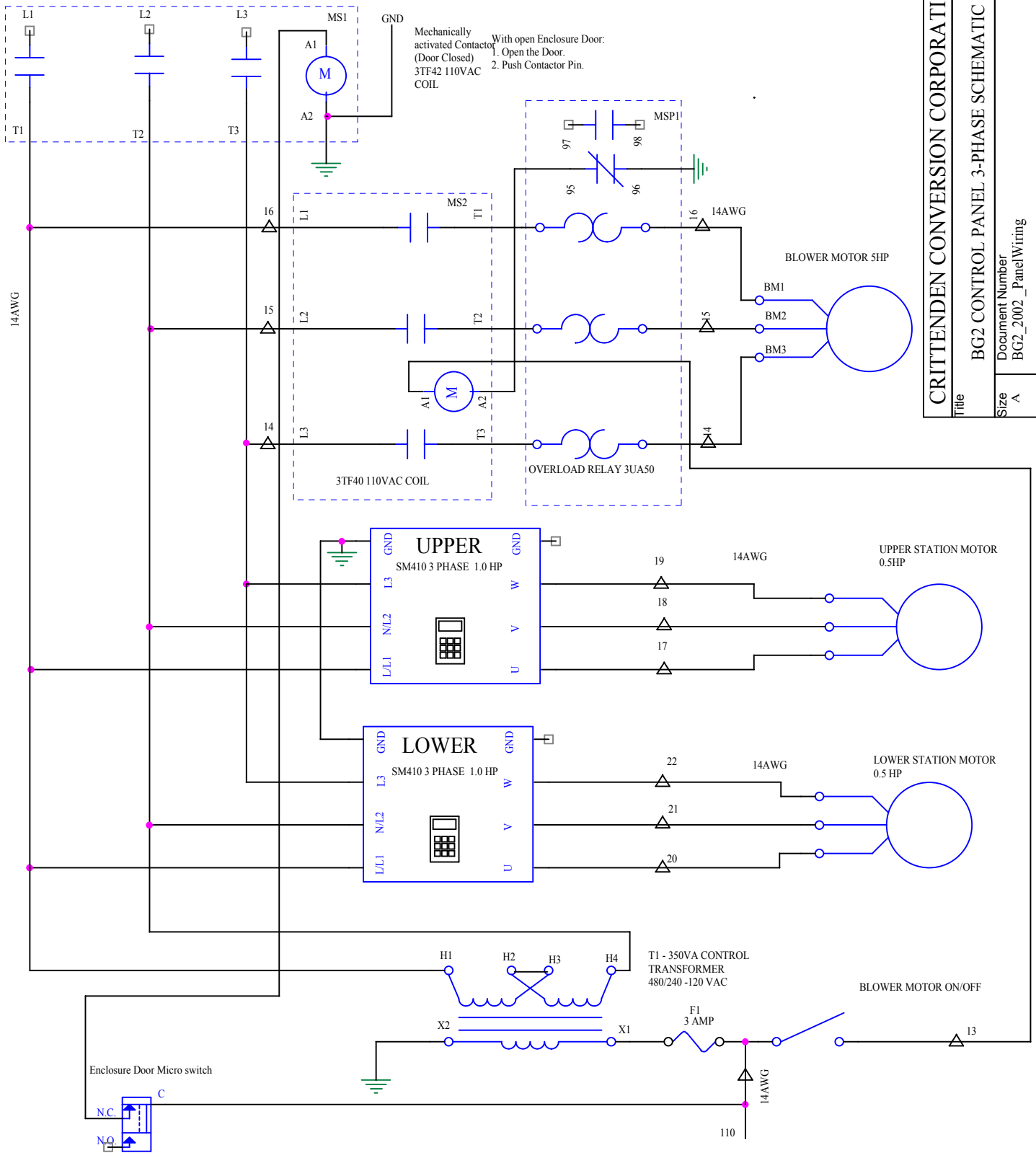
- 1 CONDUITS AND JUNCTION BOXES
- 2 CABLES
- 3 JUNCTION BOX #1
- 4 MANUAL MOVE REMOTE CONTROL BOX
- 5 JUNCTION BOX#3&#4&#5&#6
- 6 JUNCTION BOX#7&#8&#9&#10
- 7 JUNCTION BOX#11
- 8 JUNCTION BOX#12
- 9 BG2 CONTROL PANEL FRONT INSIDE WIRING

**VARIABLE FREQUENCY DRIVE SM410 PARAMETER TABLE**  
**OIT TROUBLESHOOTING**  
**BG2002 PARTS LIST**

## BRIDGE GUIDE 2002 PARTS LIST

Item	Qty	Part	Type-Title	Detail
1	1	6ES72141AD230XB0	SIEMENS PLC CPU-224 DC/DC/DC	CPU with 14 Inputs, 10 Outputs
2	1	6ES72918BA200XA0	SIEMENS PLC Battery Cartridge	For PLC memory
3	1	6EP13311SH02	SIEMENS POWER SUPPLY	1.3 A 24VDC
4	1	6ES7235-OKD22-0XA0	SIEMENS Extension module 4AI(+/-) 1 output.	Analog 4 inputs, 1 output
5	1	OIT 3185-A00	Maple System Operator Interface Terminal (OIT)	OIT RJ45 connector; RS-232, RS-422 or RS-485
6	1	7442-0025-5	Maple System Communication Cable for OIT	RJ45, DE9P connectors, twisted 3- pair shielded cable
7	2	SM410	ACTech Variable Speed AC Motor Drive	480V,3PH,1.0HP,2.1A
8	1	MT0350A	SIEMENS TRANSFORMER	350 VA 50/60 Hz 480-120
9	1	24VDC/12VDC-VR-2004/02/03	Crittenden DC/DC converter	DIN rail mount 24/12 VDC
10	2	PVSM2-2002/12/21	Crittenden Vacuum/Pressure Sensor Module	DIN rail mount
11	6	PLC-BSC-24DC/21	Phoenix Contact. Relay	DIN Rail Mount, 24 VDC, Output: max 250V/6A
12	2	FBST-500-PLC	Phoenix Contact. Relay plug-in jumper, Blue and Red	
13	1	LC1D12G7	SQD Contuctor	DIN Rail Mount
14	6	SIE52SB2BDB	SIEMENS selector switch	3 pos, sp. Rtn.L&R to C LONG LEVER
15	3	SIE52SB2AAB	SIEMENS selector switch	2 pos. MTN, LONG LEVER
16	15	SIE52BAK	SIEMENS N/O CONTACT BLOCK	
17	2	HRL1Q-200/12C	Photocraft Encoder	200 p/rev, 12 VDC, with cable
18	1	KCN0180	HONEYWELL MICRO SWITCH	Panel mounted
19	1	14DSD32BA	SIEMENS BLOWER MOTOR STARTER OVERLOAD RELAY	(110-120/220-240)NEMA1
20	5	8WA1 808	SIEMENS Terminal Blocks END RETAINER	Din rail Mount
21	6	8WA1 011-1PG00	SIEMENS Terminal Blocks (GROUND)	Din rail Mount
22	6	8WA1 011-1DF11	SIEMENS Terminal Blocks Single Pole	Din rail Mount
23	2	8WA1 011-0DF21	SIEMENS Terminal Blocks 10-POLE	Din rail Mount
24	1	8WA1 011-0DG21	SIEMENS Terminal Blocks 10-POLE	Din rail Mount
25	1	CTMBG200x, RPS 22-18/2.00-9	CRITTENDEN TERMINAL MARKERS, Wire markers	
26	2	UK 5-HES1	Fuse holder	DIN Mount
27	1	ATQ4, GM2, GMA500ma	Fuse 4 Amp, Fuse 2 Amp, Fuse .5 Amp	
28	1	C-SD 30208, C-P3020	HOFFMAN BOX, PANEL	30x20x8
29	1	E2PB	Vert.Pushbutt. Enclosure	Type12, 2 holes
30	1	EZ-501-8FT	Parker Air fitting coupler	
31	1	CCCSBG200x	CRITTENDEN Stickers on the front panel	Front Panel
32	1	dmr1	Phoenix Contact. Din mounting Rail	
33	1	ASE 12x8x4	Hoffman Box 12x8x4	Junction Box #1
34	9	G1X2LG6, C1LG6	Panduit Corp. PLASTIC WIRING DUCT, DUCT COVER	(1"x 2"x 6') (FEET)

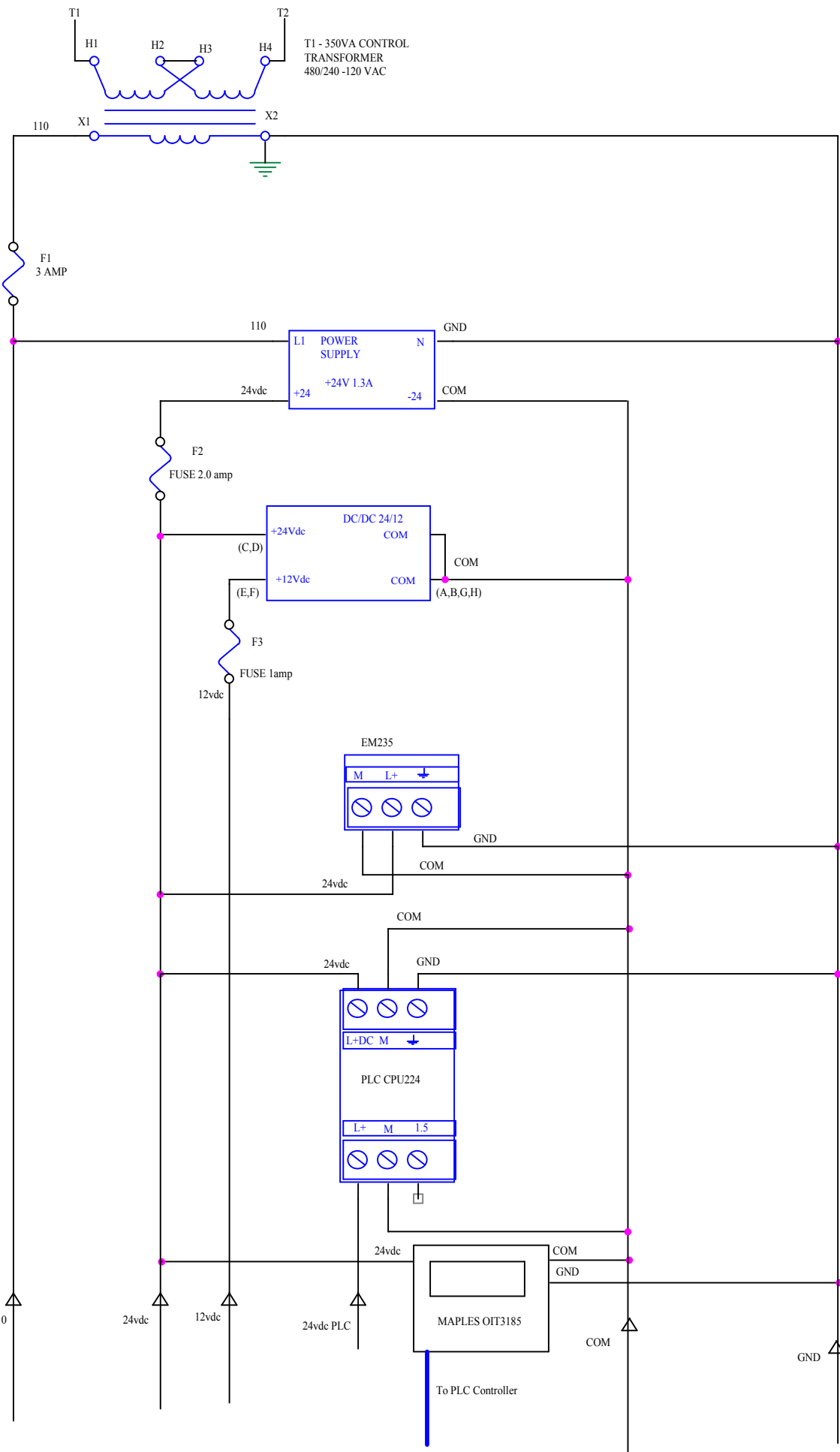
460 VAC 60 Hz 3-PHASE MAIN  
POWER FEEDER 15 AMP



Mechanically activated Contactor (Door Closed)  
3TF42 110VAC COIL

With open Enclosure Door:  
1. Open the Door.  
2. Push Contactor Pin.

<b>CRITTENDEN CONVERSION CORPORATION</b>	
Title BG2 CONTROL PANEL 3-PHASE SCHEMATIC	
Size A	Document Number BG2_2002_Panel Wiring
Rev A	Rev A
Date: Monday, December 11, 2006	Sheet 1 of 12



**CRITTENDEN CONVERSION CORPORATION**

Title: BG2 CONTROL PANEL 120VAC TO 24/12 VDC DISTRIBUTION

Size	A	Rev	A
Document Number	BG2_2003_PanelWiring		

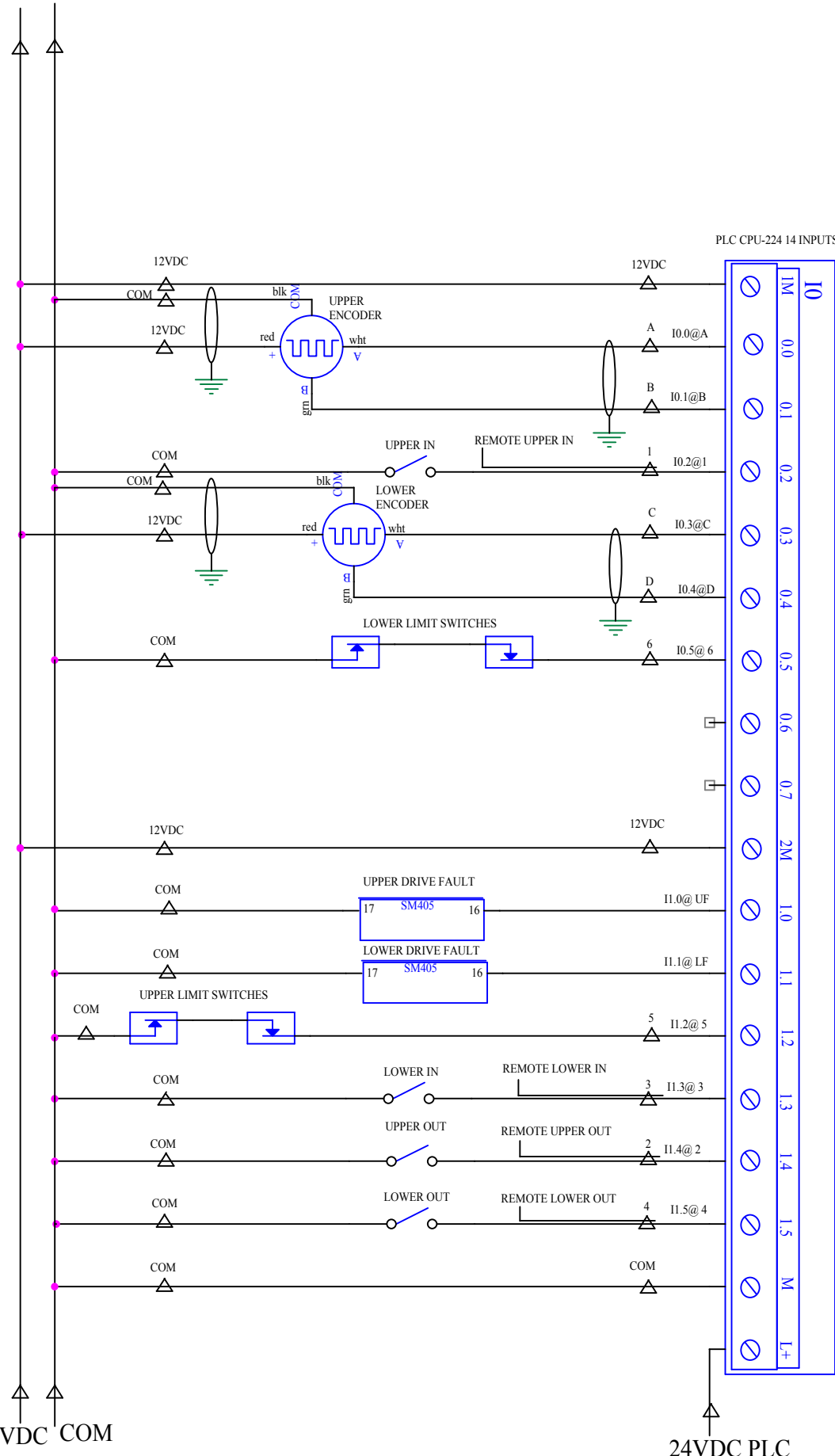
Date: Thursday, October 11, 2007 Sheet 2 of 12



+12VDC COM

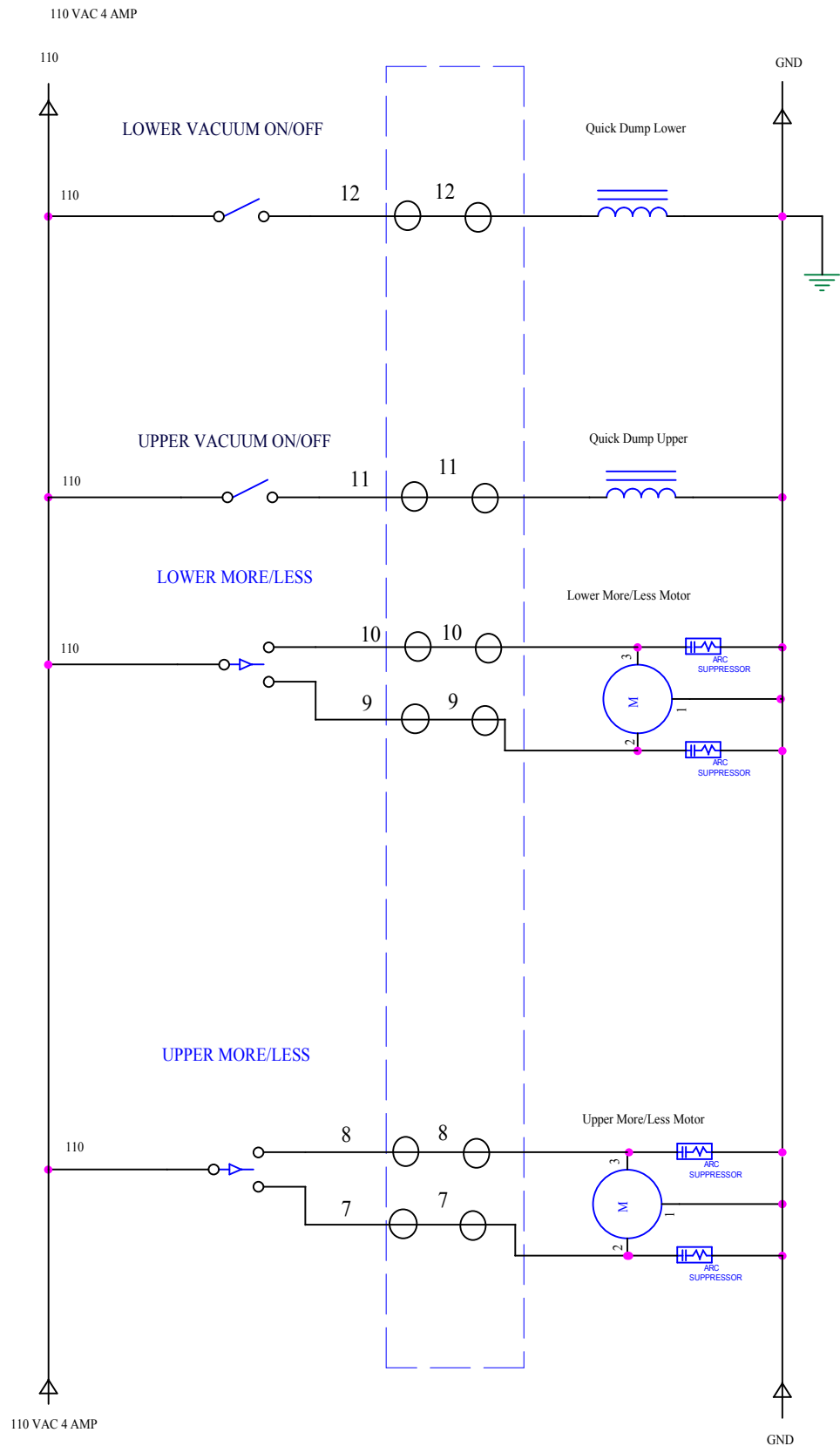
+12VDC COM

PLC CPU-224 14 INPUTS

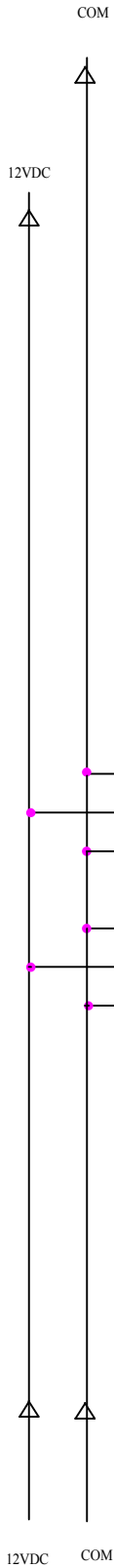


10	10.0	10.1	10.2	10.3	10.4	10.5	10.6	10.7	2M	10	11.0	11.1	11.2	11.3	11.4	11.5	M	1+
----	------	------	------	------	------	------	------	------	----	----	------	------	------	------	------	------	---	----

<b>CRITTENDEN CONVERSION CORPORATION</b>	
Title	BG2 CONTROL PANEL PLC INPUTS MAIN MODULE
Size	Document Number BG2_2003_PanelWiring
Rev	A
Date:	Monday, December 11, 2006
Sheet	3 of 12



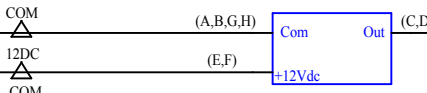
<b>CRITTENDEN CONVERSION CORPORATION</b>		
Title BG2 CONTROL PANEL VACUUM CONTROL SWITCHES SCHEMATIC		
Size A	Document Number BG2_2003_PanelWiring	Rev A
Date: Friday, September 28, 2007	Sheet 4	of 12



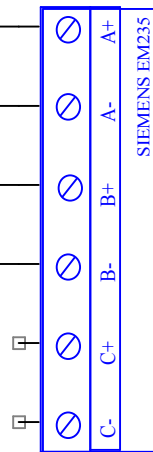
UPPER VACUUM SENSOR



LOWER VACUUM SENSOR



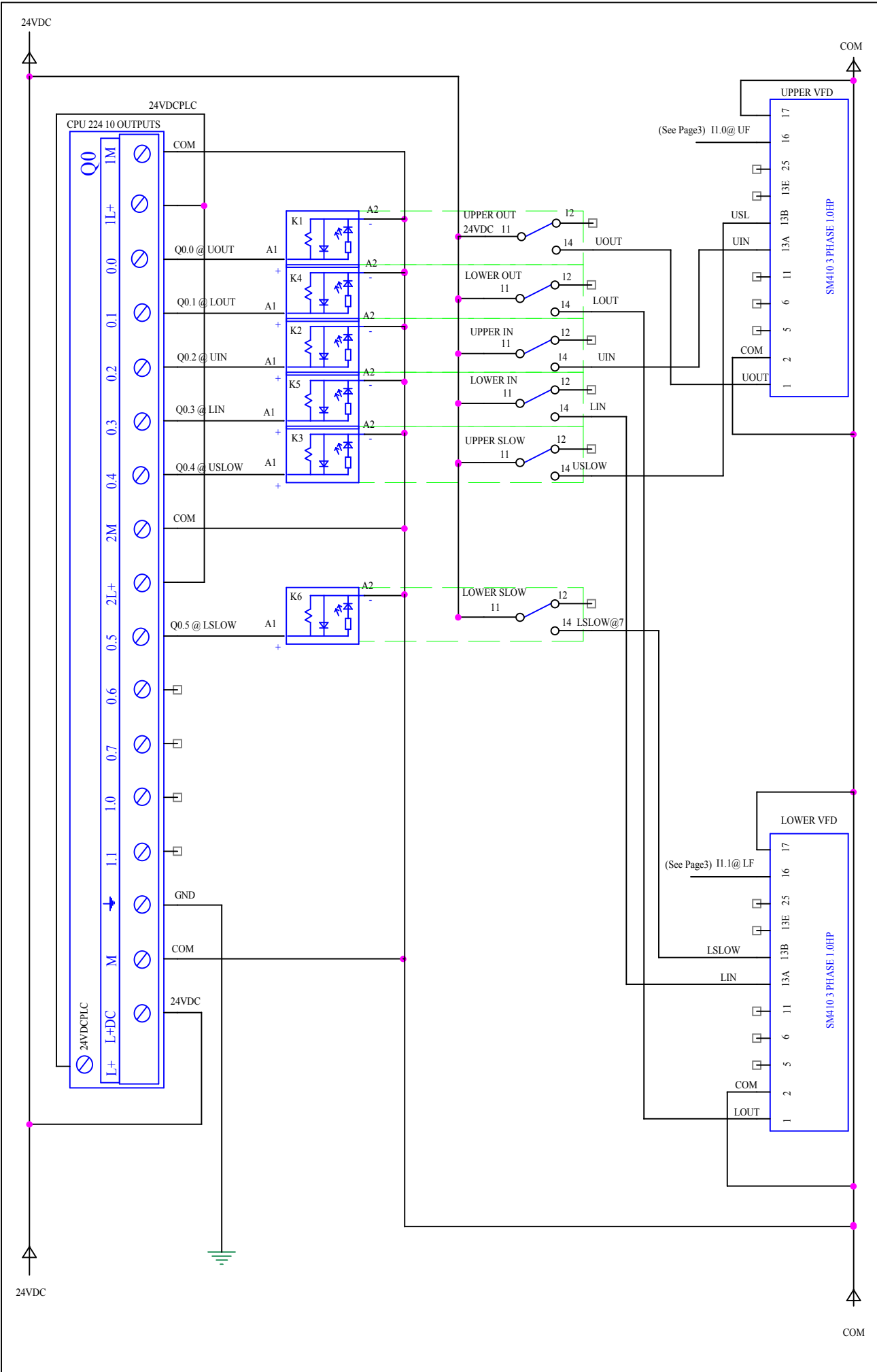
EXTENSION MODULE 4 ANALOG INPUTS EM235



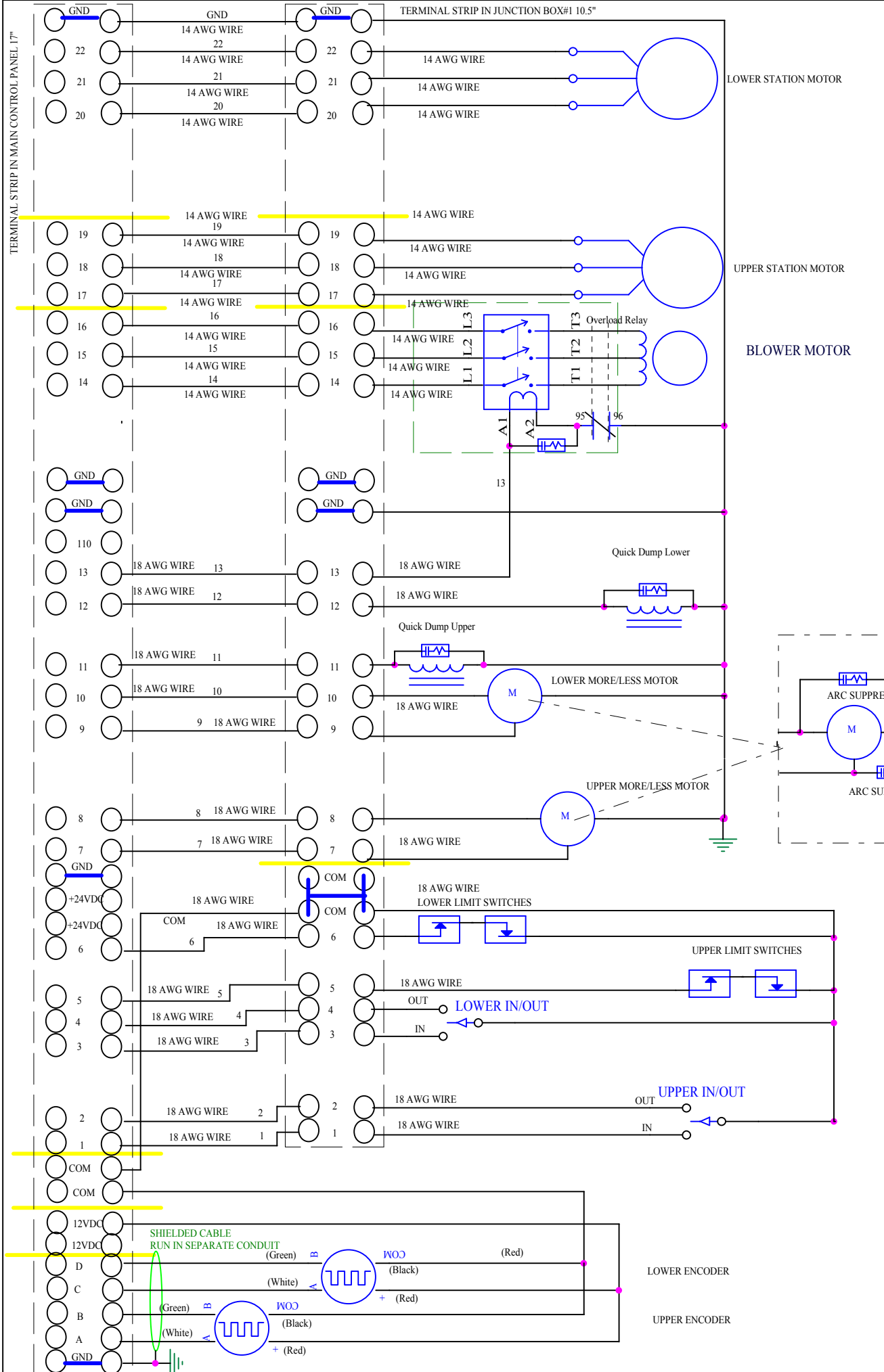
Extension module EM  
235 Configuration  
Switch Settings



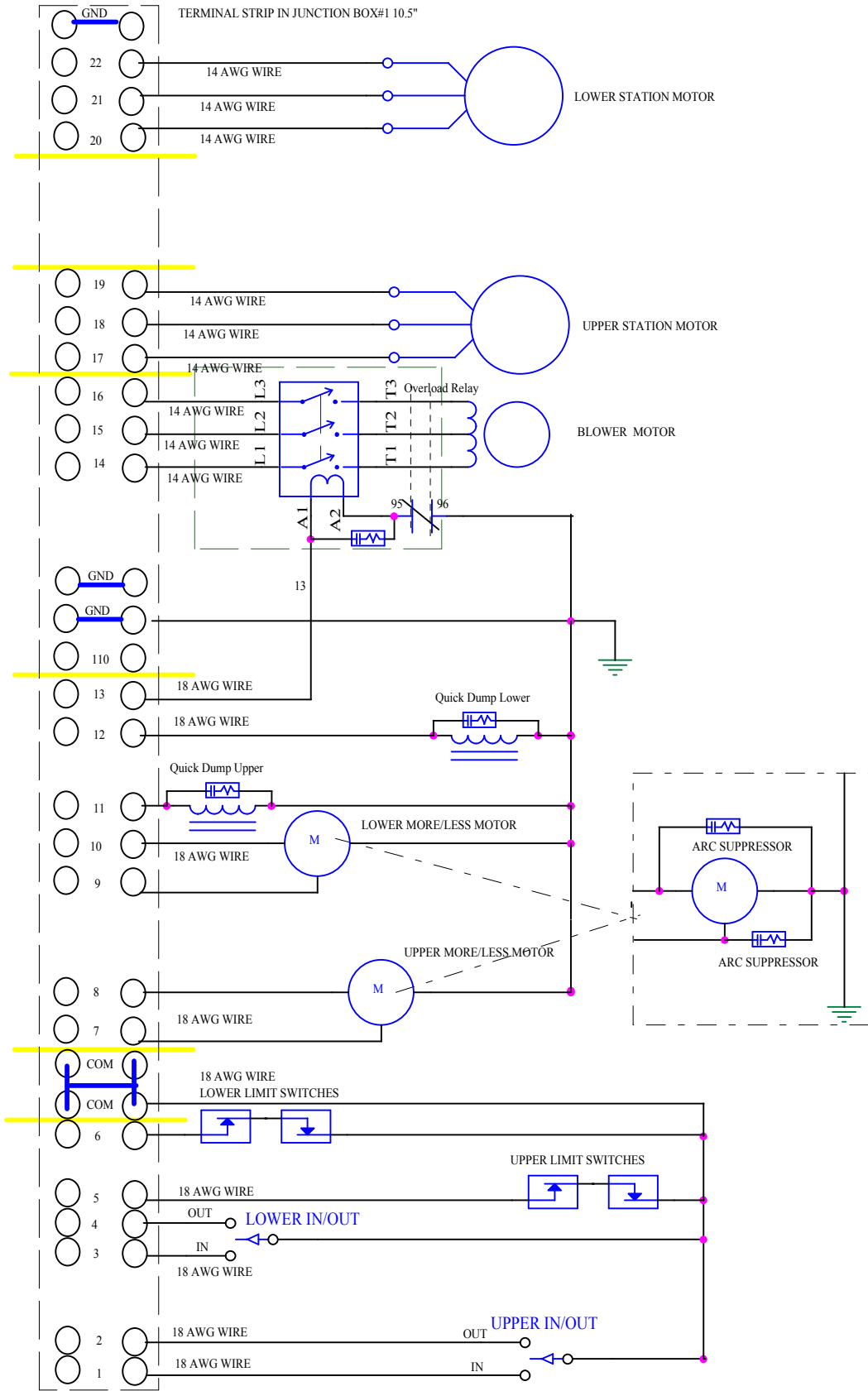
<b>CRITTENDEN CONVERSION CORPORATION</b>	
Title BG2 CONTROL PANEL EXTENSION MODULES INPUTS SCHEMATIC	
Size A	Document Number BG2_2003_PanelWiring
Rev A	Rev A
Date: Monday, May 10, 2004	Sheet 5 of 12



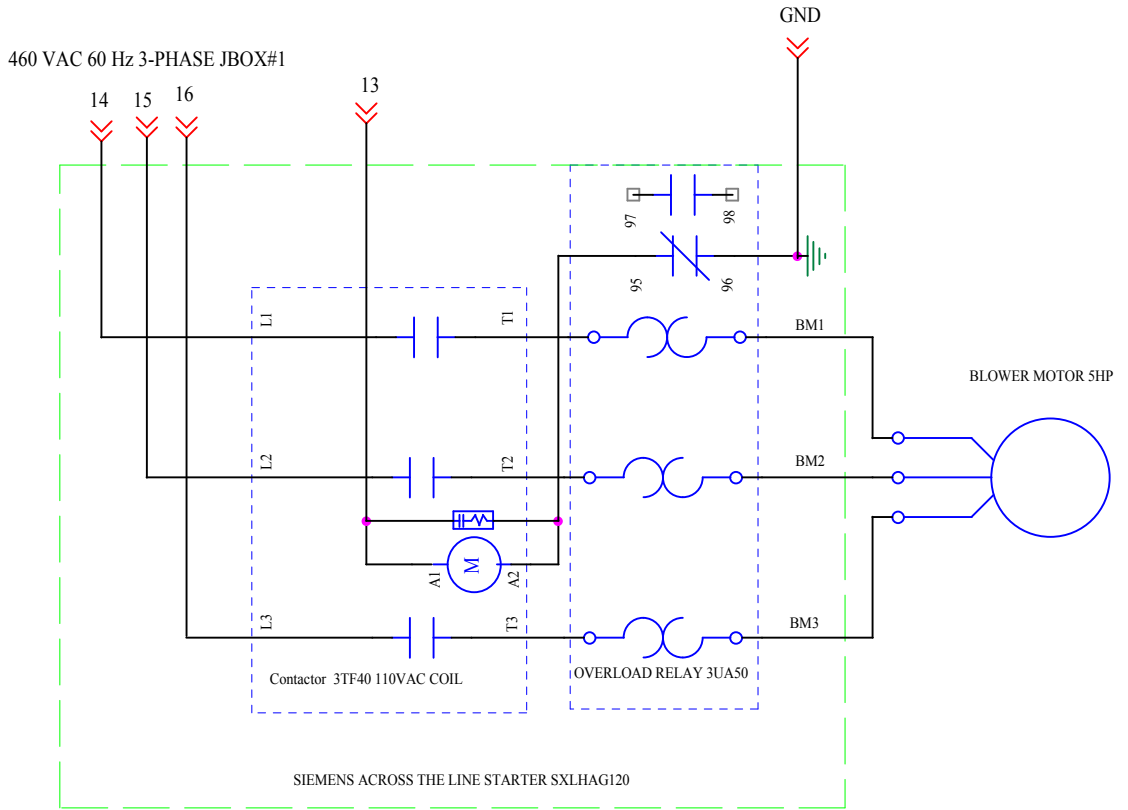
<b>CRITTENDEN CONVERSION CORPORATION</b>	
Title	BG2 CONTROL PANEL OUTPUTS SCHEMATIC
Size	Document Number BG2_2003_PanelWiring
Rev	A
Date:	Wednesday, September 13, 2006
Sheet	6 of 12



<b>CRITTENDEN CONVERSION CORPORATION</b> Title BG2 CONTROL PANEL TERMINAL STRIP WIRING SCHEMATIC		Rev	A
		Size	A
Document Number BG2_2003_PanelWiring		Date:	Friday, January 23, 2009
Sheet	7	of	12

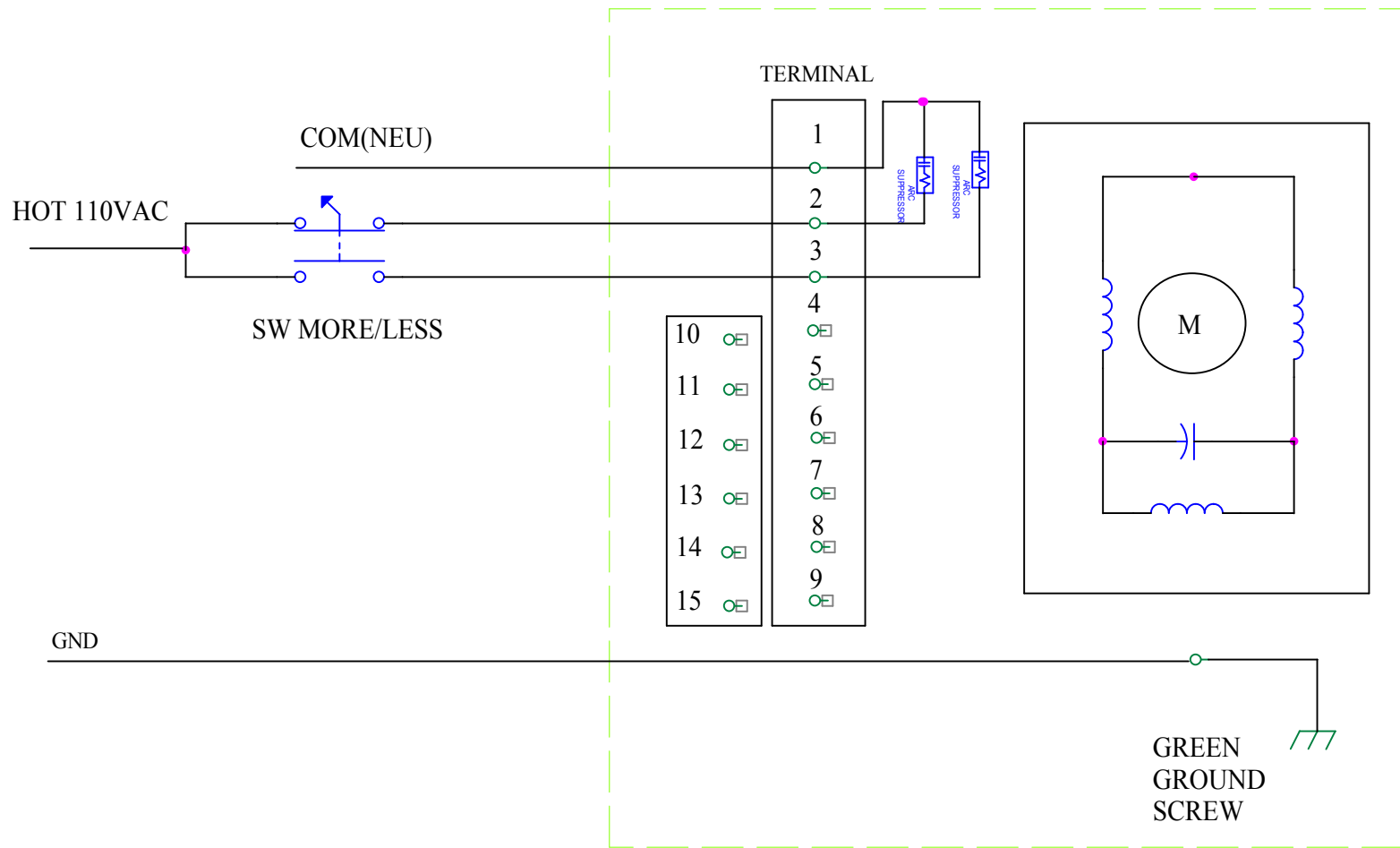


<b>CRITTENDEN CONVERSION CORPORATION</b>	
Title	BG2 CONTROL PANEL BOX#1 TERMINAL STRIP WIRING SCHEMATIC
Size	Document Number BG2_2003_PanelWiring
Rev	A
Date:	Wednesday, August 30, 2006
Sheet	8 of 12



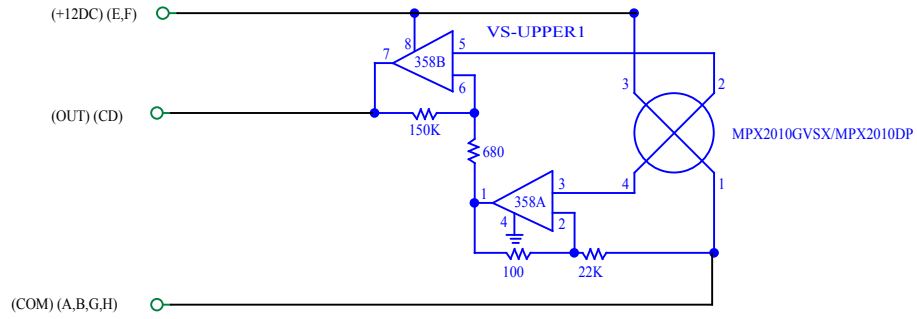
**CRITTENDEN CONVERSION CORPORATION**

Title		BG2 BLOWER 3-PHASE SCHEMATIC	
Size	Document Number	Rev	
A	BG2_2003	A	
Date:	Monday, May 10, 2004	Sheet	9 of 12

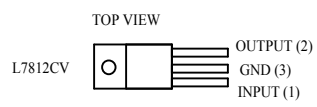
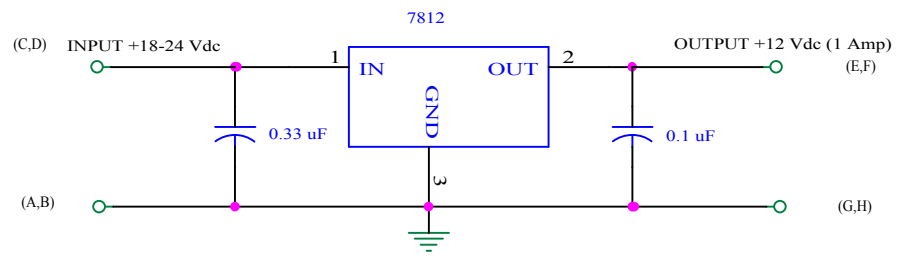


CRITTENDEN CONVERSION CORPORATION		
Title MODEL MAR8-8 120 50/60 0.6 AMP (VACUUM MORE/LESS)		
Size A	Document Number BG2_2003.DSN	Rev A
Date:	Monday, October 05, 2009	Sheet 10 of 12





CRITTENDEN CONVERSION CORPORATION		
Title BG-2002 - Vacuum Unit		
Size A	Document Number BG2_2003 3-PANEL WIRING.DSN	Rev A
Date:	Monday, June 02, 2008	Sheet 11 of 12



CRITTENDEN CONVERSION CORPORATION		
Title DC/DC CONVERTER 24-12 VDC PHOENIX		
Size A	Document Number BG2_2003_PanelWiring	Rev A
Date:	Thursday, October 11, 2007	Sheet 12 of 12

## APPENDIX B

VARIABLE FREQUENCY DRIVE SM410 PARAMETER TABLE

NO.	PARAMETER NAME	RANGE OF ADJUSTMENT	FACTORY DEFAULT	YOURS
01	LINE VOLTAGE	HIGH (01), LOW (02)	HIGH (01)	-----
02	CARRIER FREQUENCY	4kHz (01), 6 kHz (02), 8 kHz (03), 10 kHz (04)	6 kHz (02)	-----
03	START METHOD	NORMAL (01), START ON POWER UP (02), START WITH DC BRAKE (03), AUTO RESTART WITH DC BRAKE (04), FLYING RESTART 1 (05), FLYING RESTART 2 (06), FLYING RESTART 3 (07)	NORMAL (01)	-----
04	STOP METHOD	COAST (01), COAST WITH DC BRAKE (02), RAMP (03), RAMP WITH DC BRAKE (04)	COAST (01)	<b>RAMP (03)</b>
05	STANDARD SPEED SOURCE	KEYPAD (01), PRESET #1 (02), 0-10 VDC (03), 4-20 mA (04)	KEYPAD (01)	<b>PRESET#1 (02)</b>
06	RELAY OUTPUT	NONE (01), RUN (02), FAULT (03), INVERSE FAULT (04), FAULT LOCKOUT (05), AT SET SPEED (06), ABOVE PRESET #3 (07), CURRENT LIMIT (08), AUTO SPEED (09), REVERSE (10)	NONE (01)	<b>INVERSE FAULT (04)</b>
10	TB-13A FUNCTION SELECT	NONE (01), 0-10 VDC (02), 4-20 mA (03), PRESET SPEED #1 (04), START FORWARD (05), RUN REVERSE (06), START REVERSE (07), EXTERNAL FAULT (08), INVERSE EXT FAULT (09), AUXILIARY STOP (10), ACCEL/DECCEL #2 (11)	NONE (01)	<b>RUN REVERSE (06)</b>
11	TB-13B FUNCTION SELECT	NONE (01), 0-10 VDC (02), 4-20 mA (03), PRESET SPEED #2 (04), DECREASE FREQ (05), START FORWARD (06), JOG FORWARD (07), JOG REVERSE (08), EXTERNAL FAULT (09), INVERSE EXT FAULT (10), AUX. STOP (11), ACCEL/DECCEL #2 (12), REMOTE KEYPAD (13)	NONE (01)	<b>PRESET SPEED 2 (04)</b>

NO.	PARAMETER NAME	RANGE OF ADJUSTMENT	FACTORY DEFAULT	YOURS
12	TB-13E INPUT FUNCTIONS	NONE (01), 0-10 VDC (02), 4-20 mA (03), PRESET SPEED #3 (04), INCREASE FREQ (05), START FORWARD (06), EXTERNAL FAULT (07), INVERSE EXT FAULT (08), AUX. STOP (09), ACCEL/DECEL #2 (10),	NONE (01)	-----
	TB-13E OUTPUT FUNCTIONS	RUN (11), FAULT (12), INVERSE FAULT (13), FAULT LOCKOUT (14), AT SET SPEED (15), ABOVE PRESET #3 (16), CURRENT LIMIT (17), AUTO SPEED (18), REVERSE (19), DYNAMIC BRAKING (20),		
	OTHER FUNCTIONS	REMOTE KEYPAD (21)		
14	CONTROL	TERMINAL STRIP ONLY (01) REMOTE KEYPAD ONLY (02)	TERMINAL STRIP ONLY (01)	-----
16	UNITS EDITING	TENTHS OF UNITS (01), WHOLE UNITS (02)	WHOLE UNITS (02)	-----
17	ROTATION	FORWARD ONLY (01), FORWARD AND REVERSE (02)	FORWARD ONLY (01)	FORWARD AND REVERSE (02)
19	ACCELERATION TIME	0.1 - 3600.0 SEC	20.0 SEC	1
20	DECELERATION TIME	0.1 - 3600.0 SEC	20.0 SEC	0.1
21	DC BRAKE TIME	0.0 - 3600.0 SEC	0.0 SEC	-----
22	DC BRAKE VOLTAGE	0.0 - 30.0 %	0.0 %	-----
23	MINIMUM FREQUENCY	0.0 - MAXIMUM FREQUENCY	0.0 Hz	-----
24	MAXIMUM FREQUENCY	MINIMUM FREQUENCY - 240 Hz	SCL = 50.0 Hz SCM = 60.0 Hz	60
25	CURRENT LIMIT	30 - 180 %	180 %	-----
26	MOTOR OVERLOAD	30 - 100 %	100 %	53-0.5hp 77-0.75hp
27	BASE FREQUENCY	25.0 - 500.0 Hz	SCL = 50.0 Hz SCM = 60.0 Hz	60
28	FIXED BOOST	0.0 - 30.0 %	1.0 %	5.3
29	ACCEL BOOST	0.0 - 20.0 %	0.0 %	-----

NO.	PARAMETER NAME	RANGE OF ADJUSTMENT	FACTORY DEFAULT	YOURS
30	SLIP COMPENSATION	0.0 - 5.0 %	0.00%	-----
31-37	PRESET SPEEDS	0.0- MAXIMUM FREQUENCY	0.0 Hz	<b>31 – 60; 32- 5</b>
38	SKIP BANDWIDTH	0.0 - 10.0 Hz	0.0 Hz	-----
39	SPEED SCALING	0.0- 6500.0	0.0	-----
42	ACCEL/ DECEL #2	0.1 - 3600.0 SEC	20.0 SEC	<b>0.1</b>
44	PASSWORD	000 - 999	225	<b>0</b>
45	SPD AT MIN SIGNAL	MINIMUM FREQUENCY - 999 Hz	0.0 Hz	-----
46	SPDAT MAX SIGNAL	MINIMUM FREQUENCY - 999 Hz	SCL = 50.0 Hz SCM = 60.0 Hz	-----
47	CLEAR HISTORY	MAINTAIN (01), CLEAR (02)	MAINTAIN (01)	-----
48	PROGRAM SELECTION	USER SETTINGS (01), OEM SETTINGS (02), RESET OEM (03), RESET 60 (04), RESET 50 (05), TRANSLATE (06)	SCL = RESET 50 (05) SCM = RESET 60 (04)	-----
50	FAULT HISTORY	(VIEW-ONLY)	(NA)	-----
51	SOFTWARE CODE	(VIEW-ONLY)	(NA)	
52	DC BUS VOLTAGE	(VIEW-ONLY)	(NA)	
53	MOTOR VOLTAGE	(VIEW-ONLY)	(NA)	
54	LOAD	(VIEW-ONLY)	(NA)	
55	0-10VDC INPUT	(VIEW-ONLY)	(NA)	
56	4-20 mA INPUT	(VIEW-ONLY)	(NA)	
57	TB STRIP STATUS	(VIEW-ONLY)	(NA)	
58	KEYPAD STATUS	(VIEW-ONLY)	(NA)	

## APPENDIX C

# Troubleshooting

## Display Brightness and Viewing Angle

### Can the VFD Brightness be Changed?

Yes. In OITware-200 press SHIFT+F4 to open the OIT General Settings dialog box. In the Brightness group box, select the 100%, 75%, 60%, or 30% option button.

### Can the LCD Viewing Angle be Changed?

Yes; except on the OIT3600. To change the LCD viewing angle on the OIT5400, refer to the Installation Manual that came with the OIT. For the OIT3160, OIT3165, OIT3175, OIT3185, OIT3200 or OIT3250, in OITware-200 press SHIFT+F4 to open the OIT General Settings dialog box. In the LCD Contrast group box, select the appropriate option button.

## OIT Operation

### OIT Displays a Blank Screen when power is applied

#### Possible Causes:

- If the OIT displays a blank screen and you hear a steady beeping, then the OIT does not contain a complete project and is waiting in download/upload mode for OITware-200 to download a project. Simply connect the OIT to your computer and use OITware-200 to download a new project to the OIT.
- If the OIT displays a blank screen after displaying "Initializing" and "Attaching to PLC", then the OIT is communicating to the PLC, waiting for a command from the PLC or from the keyboard to display a message. Configure one of your messages as a startup message if you want a message to automatically display on the OIT after power is applied.

#### Possible Solutions:

- Download the OITware-200 project, OIT operational software, and PLC protocol software to the OIT again. Follow the steps in the Downloading an OITware-200 Project section in CHAPTER 1: Getting Started.
- Configure one of the messages as a startup message.

### OIT is Not Displaying Expected Information on the Display

#### Possible Causes:

- The OIT does not contain the entire OITware-200 project, OIT operational software, or PLC protocol software.
- The OITware-200 project was not configured to do what you expect.

#### Possible Solutions:

- Download the OITware-200 project, OIT operational software, and PLC protocol software to the OIT again. Follow the steps in the Downloading an OITware-200 Project section in CHAPTER 1: Getting Started. Observe the messages on both the PC and OIT.

Note any messages that indicate a problem.

- Review the OITware-200 project.

## **When the PLC Requests the Same Screen Twice the Screen is Not Displayed**

### **Possible Cause:**

- If the MRR already contained the screen number that the PLC requested, the OIT would not recognize the screen request.

### **Possible Solution:**

- Modify the PLC program so that when the MRR already contains the screen number that the PLC is requesting, the PLC writes a zero to the MRR before writing the screen number.
- If using an OIT3100 and OIT4100 Series, activate the Clear Register/Bit After Receiving Screen Request feature. Refer to the Configuring the MRR with Enhanced Features section in CHAPTER 5: Displaying Stored Screens.

## **OITware-200 PC Displays “Out of Memory” When Starting OITware-200**

### **Possible Cause:**

- The computer does not have sufficient resources to run OITware-200.

### **Possible Solution:**

- Use a computer that has at least 4MB of RAM.

## **OITware-200 Displays “Timeout Detected. OIT did not respond.”**

### **Possible Causes:**

- The OIT is not connected to the PC or is not in Download/Upload Mode.
- OITware-200 is not using the correct COM port.
- The configuration cable is not wired correctly.
- The configuration cable is not connected to the correct port on the OIT or the PC.
- If your OIT has two serial ports, something is connected to the RTS/CTS lines on port 1.

### **Possible Solutions:**

- Verify that the configuration cable is wired correctly and is in good condition.
- Follow the steps in the Downloading an OITware-200 Project section in CHAPTER 1: Getting Started.
- If your OIT has two serial ports, verify nothing is connected to the RTS/CTS lines on port 1.

## **OIT to PLC Communication**

### **OIT Displays “Cannot Connect To PLC During Startup.**

**\*\*\* Reconnect in progress \*\*\*” or “Can’t connect to PLC. Retry in Progress!”**

### **Possible Causes:**

- The PLC’s mode switch is not in the correct position.
- The PLC password in the OIT does not match the PLC.

- The communication settings (baud rate, parity, data bits, stop bits) for the OIT and PLC do not match.
- The communication cable is not wired correctly.
- The communication cable is not connected to the correct port on the OIT or PLC.
- The wrong PLC protocol was downloaded to the OIT

**Possible Solutions:**

- Verify that your PLC's mode switch (if applicable) is in the correct position. The switch may need to be in a mode other than run mode; such as terminal mode or xxxxxx mode. Refer to your controller operations manual or the applicable Controller Information Sheet from Maple Systems.
- Verify that the PLC password in the OIT matches the password in your PLC. In OITware-200 press F4 to open the OIT - Controller Settings dialog box. In the Password group box, enter the correct PLC password.
- Verify that the communication settings in the OIT and PLC match. In OITware-200 press F4 to open the OIT - Controller Settings dialog box. In the OIT - Controller Serial Communications Settings group box, select the correct communication settings.
- Verify that the communication cable is wired correctly and in good condition.
- Verify that the OIT and PLC are connected correctly. Refer to the Installation Manual that came with the OIT.
- Download the project with the correct PLC protocol from OITware-200. Follow the steps in the Downloading an OITware-200 Project section in CHAPTER 1: Getting Started.

**OIT Displays “Cannot write to Msg Request Register!” or “Error: Setting up Mailbox During Startup”**

**Possible Cause:**

- The PLC address for the Message Request Register (MRR) is outside the memory supported by the PLC's CPU.

**Possible Solution:**

- Change the PLC address for the MRR. In OITware-200 press SHIFT+F6 to open the OIT Message Control Settings dialog box. In the Message Request Register group box, select a supported PLC address. If you are using the MRR enhanced features, to set the PLC address(es) for the MRR(s), refer to the Configuring the MRR section in CHAPTER 5: Displaying Stored Screens.

**OIT Displays “Cannot write to the Status Coils!” or**

**“Error: Setting up Status Coils On Startup” or**

**“Cannot set the Reset Status Coil!” or**

**“Error: Setting STAT\_RESET during Startup” or**

**“Cannot set the Alarm Empty Status Coil!” or**

**“Error: Setting ALM\_EMPTY During Startup”**

**Possible Cause:**

- The PLC address for the Status Coils is outside the memory supported by the PLC's CPU.

**Possible Solution:**



- Change the PLC address for the Status Coils. In OITware-200 press F4 to open the OIT - Controller Settings dialog box. In the Status Coils group box, select a supported PLC address.

### **OIT Displays “Cannot write to the Function Key Coils!” or “Error: Setting up Key Coils On Startup”**

#### **Possible Cause:**

- The PLC address for the Function Key Coils is outside the memory supported by the PLC’s CPU.

#### **Possible Solution:**

- Change the PLC address for the Function Key Coils. In OITware-200 press F5 to open the Function Key Editor dialog box. In the Coil Address group box, select a supported PLC address.

## **Alarms**

### **How Many Alarms are Supported?**

Each OIT can store and display up to 500 screens (250 on the OIT5400). Of these 500 screens, any or all can be alarms.

### **How are Alarms Displayed?**

The PLC requests an alarm screen by placing the number that corresponds to that screen in the Message Request Register (MRR). When the OIT reads the number in the MRR, the OIT displays the corresponding alarm screen, sounds the audible alert, and blinks the alarm LED. Refer to the Alarm Screens section in CHAPTER 3: Stored Screens for more information.

### **What Happens When the OIT Operator Pushes the Alarm Ack Key?**

The audible alert is silenced, the alarm LED is cleared, and the Acknowledge Alarm status coil is set. If the alarm stack contains additional alarms, the next alarm in the stack is displayed. Otherwise, the prior non-alarm screen is displayed.

### **Is There an Alarm Stack?**

Yes, but only for pending alarms. Once the OIT operator acknowledges an alarm screen, the alarm request is terminated and discarded.

### **Alarms are Cleared Before the OIT Operator Acknowledges Them**

#### **Possible Cause:**

- The PLC is setting the Clear Alarm or Clear Alarm Stack status coil.

#### **Possible Solution:**

- Modify the PLC program so that the PLC does not set the Clear Alarm or Clear Alarm Stack status coils. From the starting PLC address for the status coils, the Clear Alarm status coil is offset 7 bits and the Clear Alarm Stack status coils is offset 8 bits. To determine the starting PLC address for the status coils, press F4 in OITware-200. The OIT - Controller Settings dialog box appears. The Status Coils group box contains the starting PLC address for the status coils.

## **When the PLC Requests the Same Alarm Twice the Alarm is Not Displayed**

Possible Cause:

- If the MRR already contained the screen number that the PLC requested, the OIT would not recognize the screen request.

### **Possible Solutions:**

- Modify the PLC program so that when the MRR already contains the screen number that the PLC is requesting, the PLC writes a zero to the MRR before writing the screen number. This allows the OIT to recognize the alarm request and does not clear the OIT's display.
- If using an OIT3160, OIT3165, OIT3175, OIT3185, OIT4160, OIT4165, OIT4175, or OIT4185, activate the Clear Register/Bit After Receiving Screen Request feature. Refer to the Configuring the MRR with Enhanced Features section in CHAPTER 5: Displaying Stored Screens.

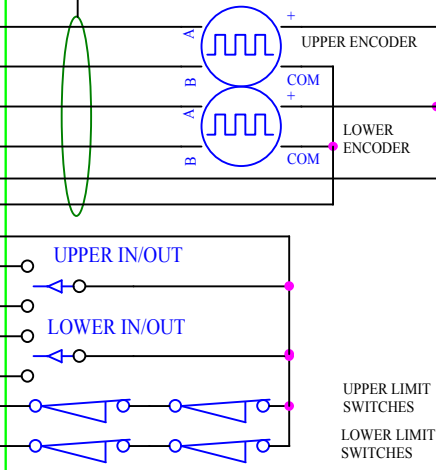
**NEW 2002 CONTROL BOX**

**TERMINAL STRIP**

GROUND SHLD
A U/ENCODER A
B U/ENCODER B
C L/ENCODER A
D L/ENCODER B
+12 VDC
COM
COM
1 U/MOVE IN
2 U/MOVE OUT
3 L/MOVE IN
4 L/MOVE OUT
5 U/LIMIT
6 L/LIMIT
7 U-MORE
8 U-LESS
9 L-MORE
10 L-LESS
11 U-QDUMP
12 L-QDUMP
13 BLWR ON
GROUND
14 BLOWER L1
15 BLOWER L2
16 BLOWER L3
17 UPPER GUIDE L1
18 UPPER GUIDE L2
19 UPPERGUIDE L3
20 LOWER GUIDE L1
21 LOWER GUIDE L2
22 LOWER GUIDE L3
GROUND

SHIELDED CABLE RUN IN SEPARATE CONDUIT

**NEW WIRING**

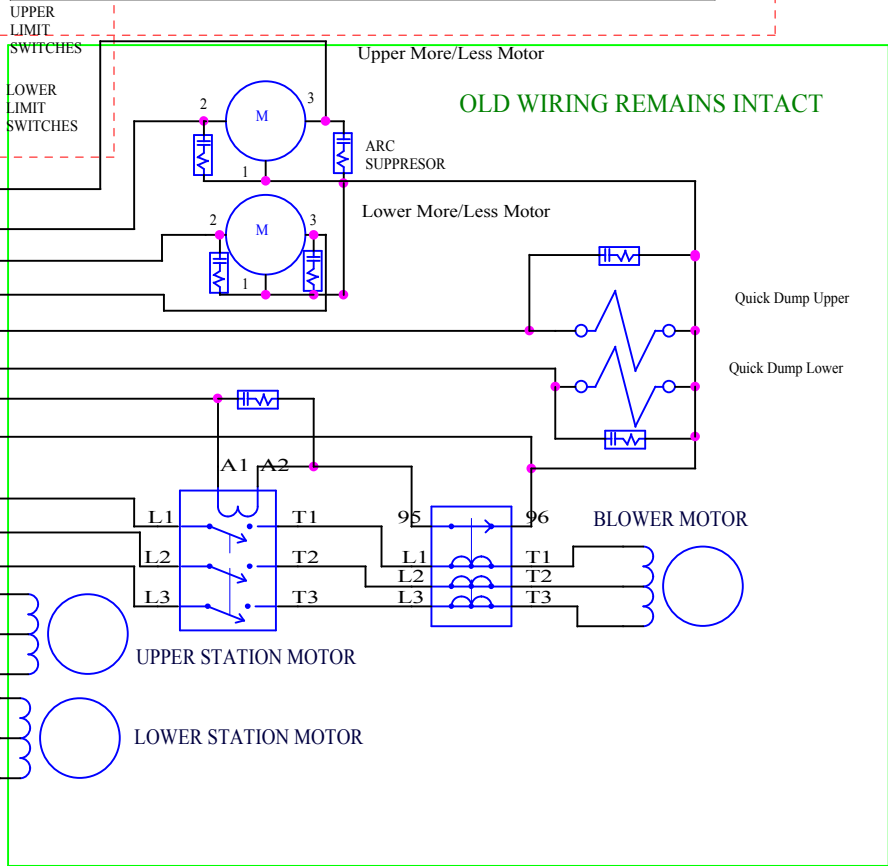
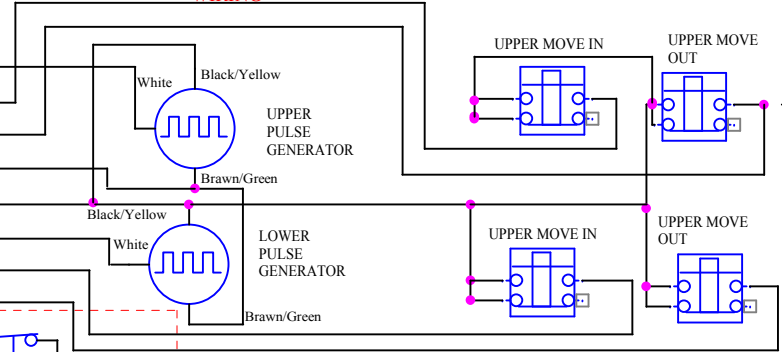


**OLD 201 CONTROL BOX**

**TERMINAL STRIP**

A U/ENCODER
B U/MOVE IN
C U/MOVE OUT
D GROUND SHLD
E +5 VDC
F L/ENCODER
G L/MOVE IN
H L/MOVE OUT
1 U/IN LIMIT
2 U/OUT LIMIT
3 GROUND
4 L/IN/ LIMIT
5 L/OUT/ LIMIT
6 O P E N
7 U-MORE
8 U-LESS
9 L-MORE
10 L-LESS
11 U-QDUMP
12 L-QDUMP
13 BLWR ON
14 GROUND
15 110 VAC HOT
16 BLOWER L1
17 BLOWER L2
18 BLOWER L3
19 UPPER GUIDE L1
20 UPPER GUIDE L2
21 UPPERGUIDE L3
22 LOWER GUIDE L1
23 LOWER GUIDE L2
24 LOWER GUIDE L3

**COMPLETELY REMOVE OLD WIRING**

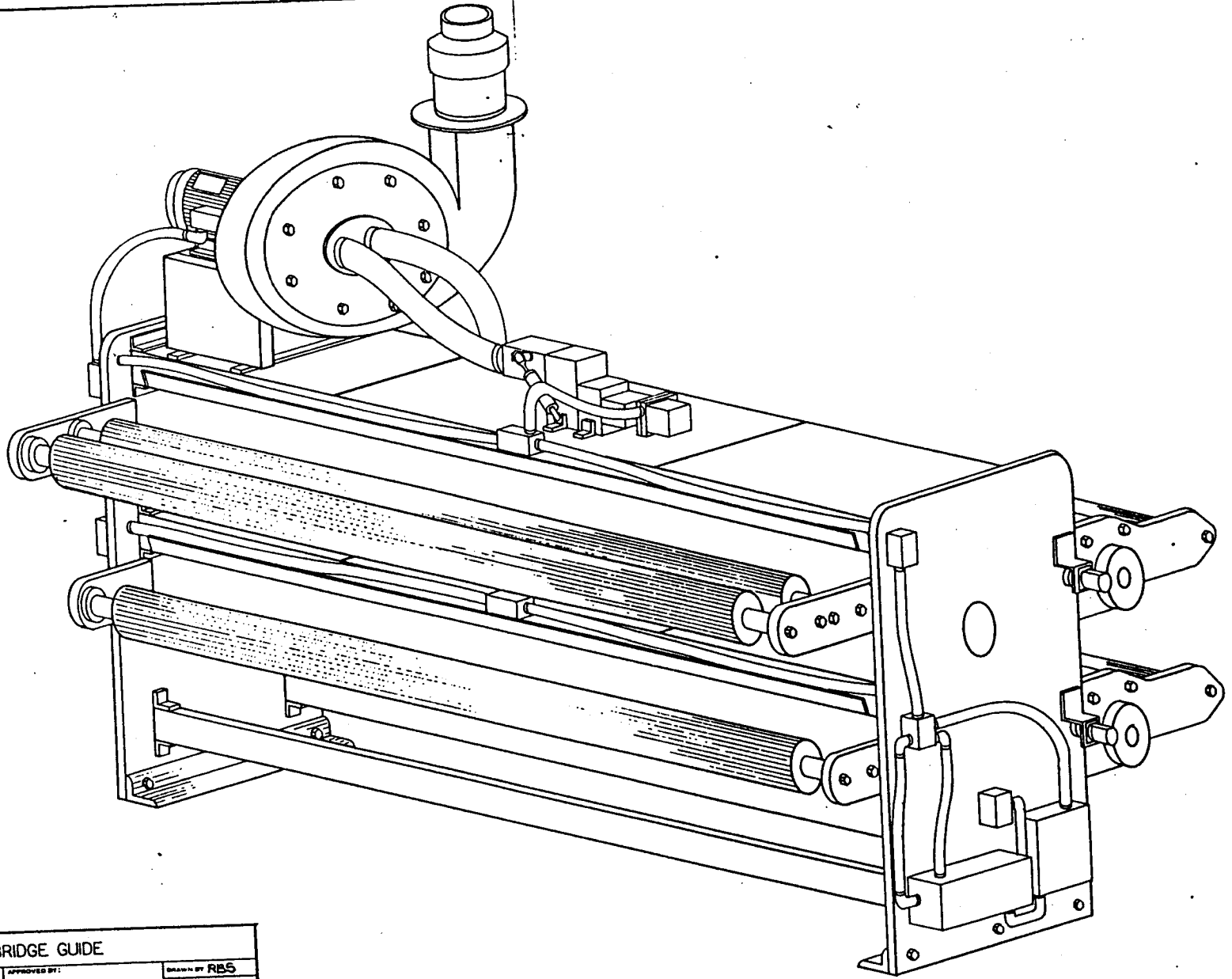


**OLD WIRING REMAINS INTACT**

**CRITTENDEN CONVERSION CORPORATION**

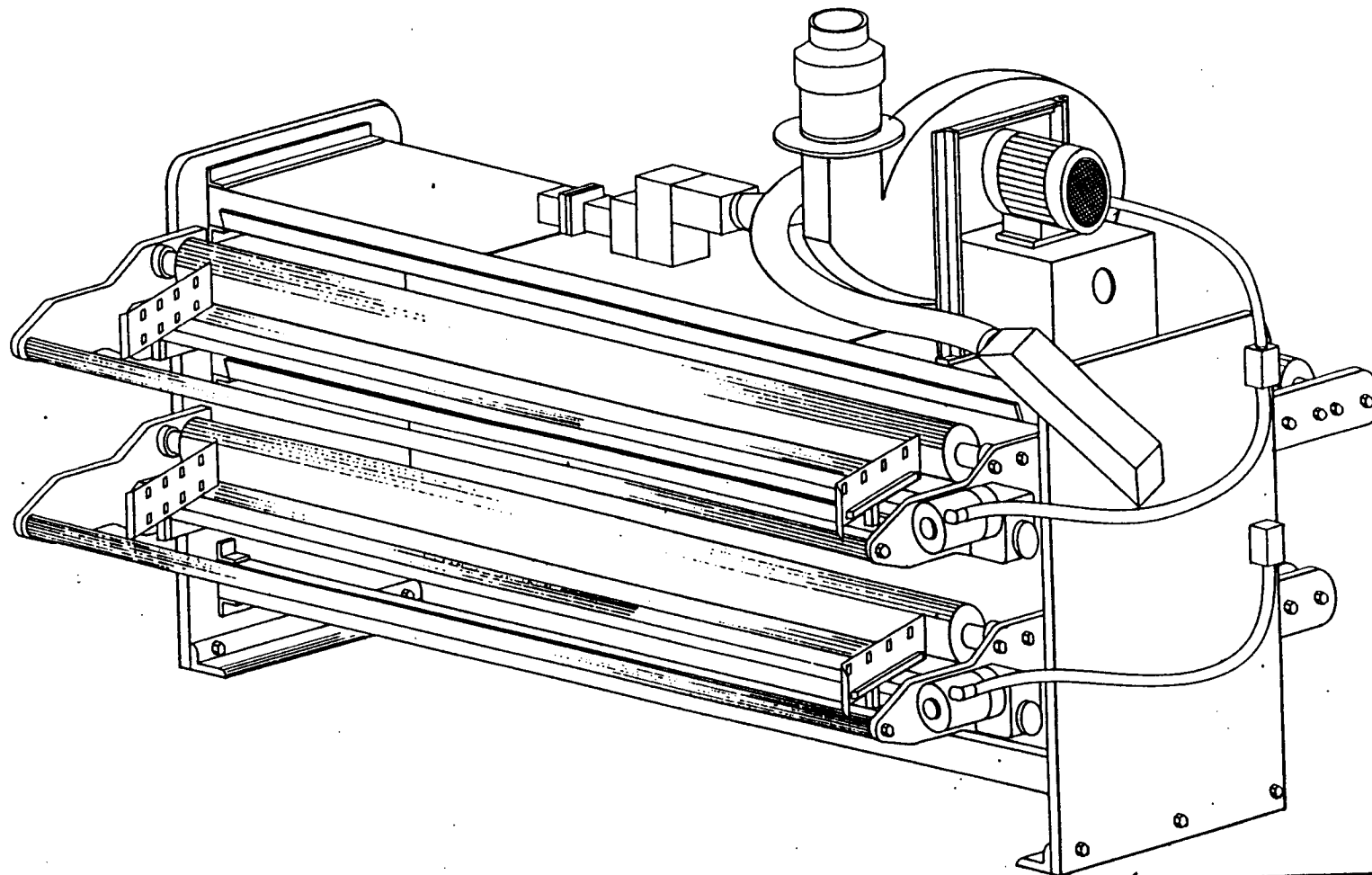
Title  
BG 201 TO 2002 CONTROL PANEL WIRING MODIFICATION

Size A	Document Number BG2-2003.dsnP11	Rev A
-----------	------------------------------------	----------



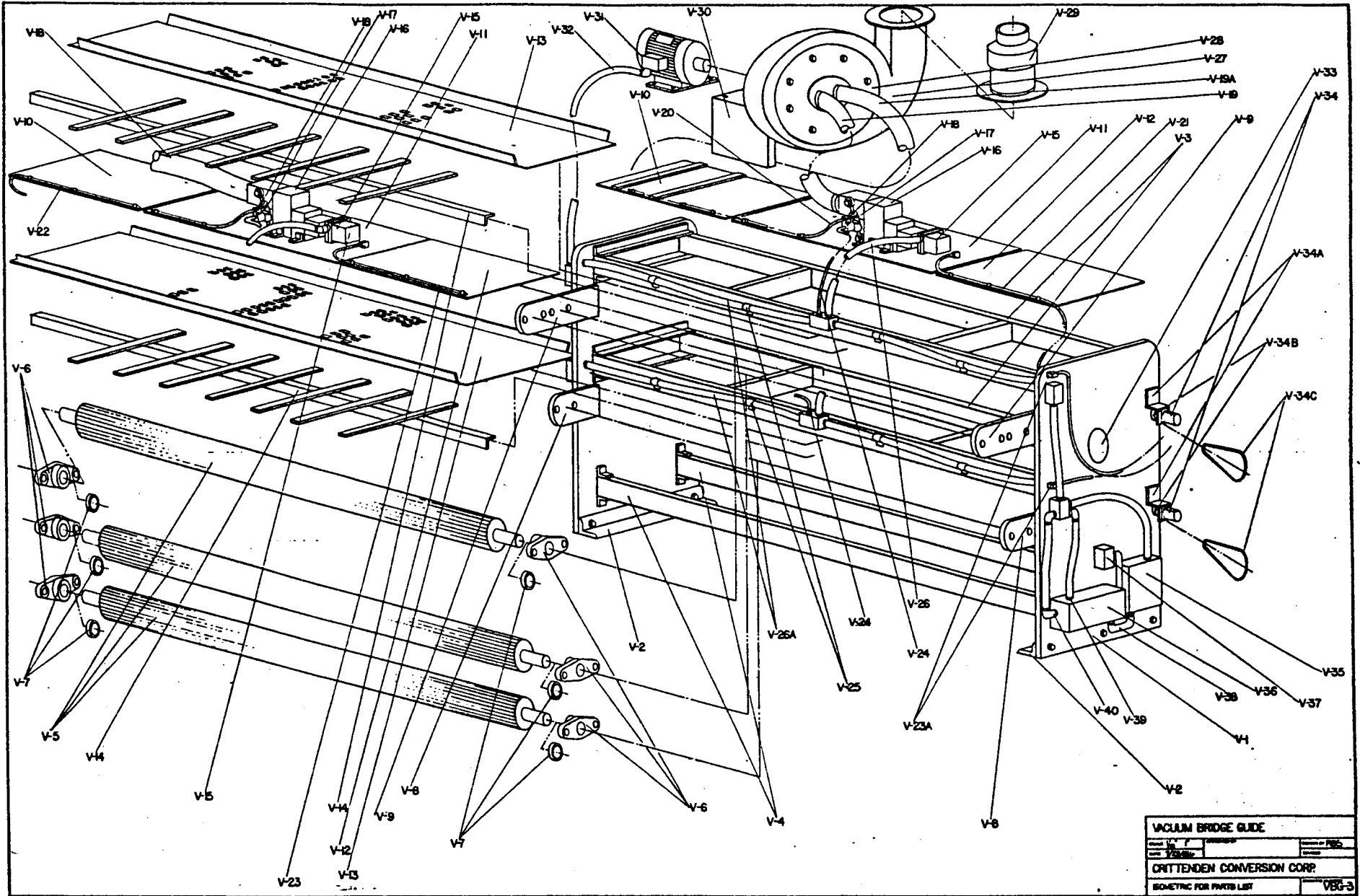
VACUUM BRIDGE GUIDE		
SCALE: $\frac{3}{8}'' = 1''$	APPROVED BY:	DRAWN BY: RBS
DATE: 7/18/66		REVISED:
CRITTENDEN CONVERSION CORP.		
ISOMETRIC FOR SALES BROCHURE		DRAWING NUMBER: VBG-1

IX

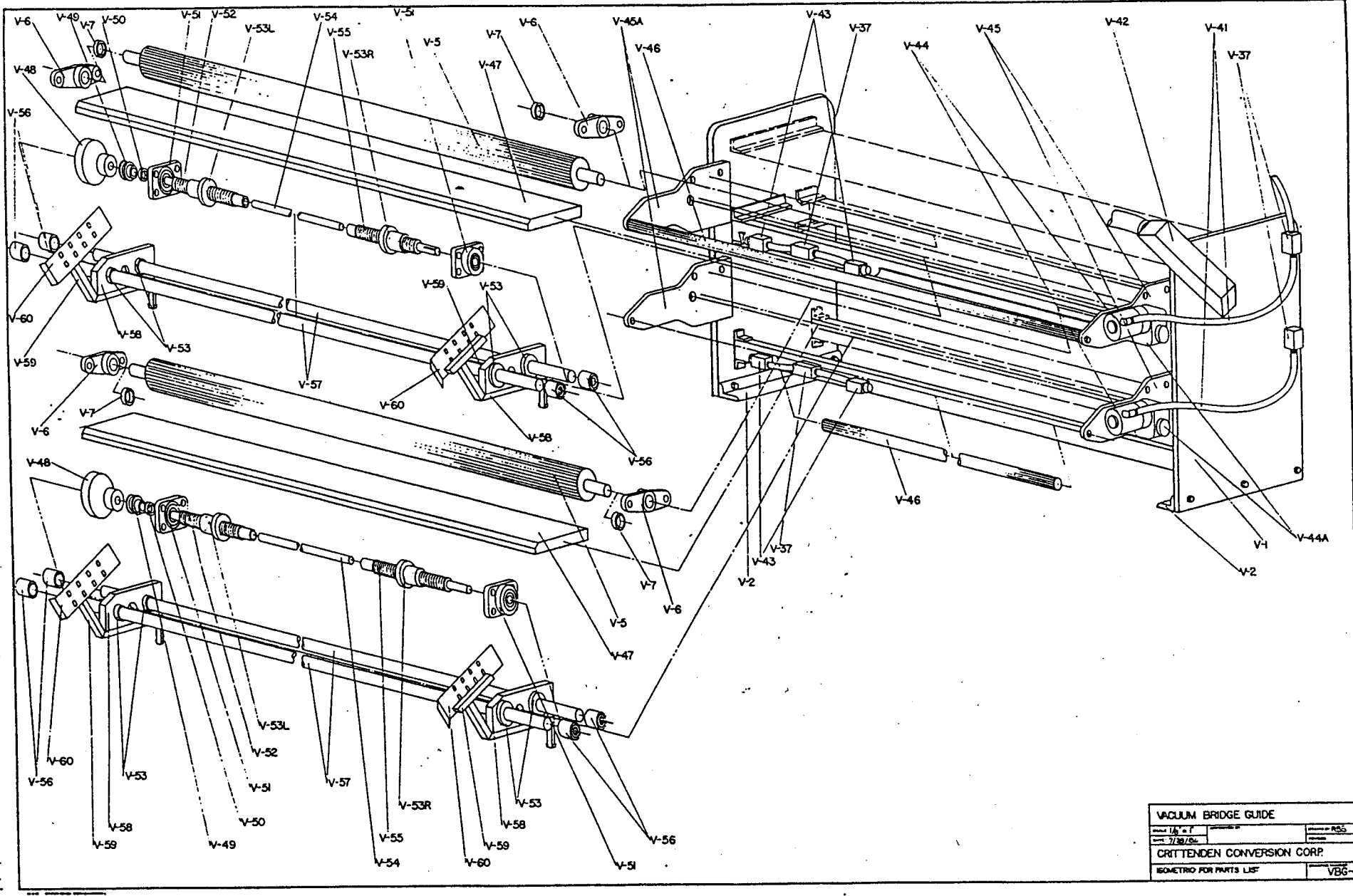


<b>VACUUM BRIDGE GUIDE</b>		
SCALE: $\frac{1}{8}'' = 1''$	APPROVED BY:	DRAWN BY: RBS
DATE: 7/21/66		REVISED:
<b>CRITTENDEN CONVERSION CORP.</b>		
ISOMETRIC FOR SALES BROCHURE	DRAWING NUMBER:	<b>VBG-2</b>

XIX



VACUUM BRIDGE GUIDE	
Part No. _____	Rev. _____
Drawn by _____	Checked by _____
CRITTENDEN CONVERSION CORP.	
ISOMETRIC FOR PARTS LIST	
V8G-3	



III X

VACUUM BRIDGE GUIDE		REV. 855
Model: 1/2" x 1"	Part: 7/30/50	
CRITTENDEN CONVERSION CORP.		
METRIC FOR PARTS LIST		VBG-4

## Spare Parts for Crittenden Vacuum Bridge Guide

Index#	Description	Part#	Notes
V-15	Butterfly actuator	MAR8R-8	
V-17	Dump Air Cylinder	SSRD091RD <sup>1</sup>	
V-18	Dump solenoid valve	111B111CA	
V-29	Vac Blower muffler	VB-EXMUF	
V-31	5HP Blower Motor	5HP3600	
V-34	5PPR Encoder	720-5	Pre 9/87
V-34C	Timing Belt	220XL037	Pre 9/87
V-44	1/3 HP Guide Motor	P56H3000	
V-44A	5:1 Gearbox	18GSF1556C87	
V-52	LH Guide Screw	1.5-4 LHS	
V-53	Guide Bushing	1.5 GCB	
V-53L	LH Guide Nut	1.5-4 LHN	
V-53R	RH Guide Nut	1.5-4 RHN	
V-55	RH Guide Screw	1.5-4 RHS	
V-57	Guide Rod	VB-GDRD	
V-60	Guide Plate	VB-GDPLT	
N/A	Durant Count/Controller	51905-400	Obsolete
N/A	Red Lion Counter	GEN42000	
N/A	Control PC Board	BGC-001	
N/A	Encoder Pickup – Guide Control	EP-001	
N/A	H2O/Vac Gauge ¼ NPT small	25.224.15"	
N/A	0-20" H2O Magnahelic gauge, lg.	DWY 2020	



BY EMPLOYING COMMON SENSE AND GOOD ENGINEERING PRACTICES THE CHANGEOVER WILL BE RELATIVELY EASY.

REMOVE OLD ENCODER BOXES AND WIRING. REMOVE OPERATOR LEAD SCREW AND 7/8" JACK SHAFT. SHORTEN JACK SHAFT BY TWO (2) INCHES. LOOSEN DRIVE GEARBOX, PULL AWAY FROM SIDE FRAME AND REASSEMBLE LEAD SCREW. NOTE ON OPERATOR SIDE THE 4 HOLE FLANGE BEARING, ORIGINALLY ON OUTSIDE OF FRAME, GOES TO INSIDE OF FRAME PER PICTURE #3.

REMOVE DRAG BRAKE ASSEMBLY FROM DRIVE GEARBOX AND REPLACE WITH RETAINING WASHERS PROVIDED PER PICTURE #1.

CENTER BEARING SUPPORT IS SECURED TO 1 1/2" SHAFT BY SET SCREWS FROM BOTTOM. REMOVE SET SCREWS THEN INSTALL SUPPORT FRAME PER PICTURE #2

AFTER LEAD SCREWS ARE REINSTALLED, SLIP ENCODER OVER END OF OPERATOR LEAD SCREW. DRILL & TAP 10-32 INTO SIDE FRAME TO SECURE ENCODER PER PICTURE #4. TIGHTEN ENCODER SET SCREWS TO LEAD SCREW.

THE MANUAL CONTROL BOX SHOULD BE MOUNTED WITHIN EASY REACH OF GUIDES.

PLEASE CALL IF THERE ARE ANY QUESTIONS  
MIKE BYRD FOR MECHANICAL QUESTIONS OR  
VITALIY SOLOMATIN FOR ELECTRICAL @ (425) 222-5167

## 16.0 TROUBLESHOOTING

To aid in troubleshooting, Parameters 50 through 60 can be accessed without entering the PASSWORD. Simply press the **Mode** button twice to “skip” over the PASSWORD prompt, and “P50” will be displayed to indicate that the parameter menu has been entered and Parameter 50 (FAULT HISTORY) can be viewed. The **▲** and **▼** buttons can then be used to scroll from Parameter 50 to Parameter 60. Once the desired parameter is found, press the **Mode** button to view its “contents”. When finished, press **Mode** to exit the parameter menu. An example is shown below:

Press **Mode** once

Display reads "00"

Upper right decimal point blinks



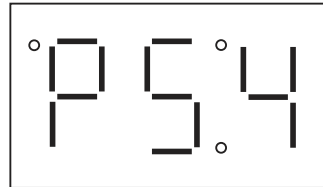
Press **Mode** again

Display reads "P50" (FAULT HISTORY)



Use **▲** and **▼** to scroll to the desired parameter number

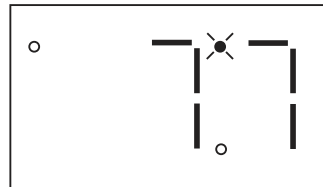
(In this example Parameter 54 has been selected, which is MOTOR LOAD)



Press **Mode** to view parameter contents (77 = 77% LOAD)

Upper right decimal point blinks

Press **Mode** again to exit



In the example above, Parameter 54 - MOTOR LOAD is being viewed. The “77” in the example indicates that the load on the motor is 77% of the output current rating of the drive.

The table below lists the fault conditions that will cause the drive to shut down, as well as some possible causes. Please contact the factory for more information on troubleshooting faults.

<b>FAULT MESSAGES</b>	
<b>FAULT</b>	<b>DESCRIPTION &amp; POSSIBLE CAUSES</b>
AF	High Temp. Fault: Ambient temperature is too high; Cooling fan has failed (if equipped).
CF	Control Fault: A blank EPM, or an EPM with corrupted data has been installed. Perform a factory reset using Parameter 48 - PROGRAM SELECTION.
cF	Incompatibility Fault: An EPM with an incompatible parameter version has been installed. Either remove the EPM or perform a factory reset (Parameter 48) to change the parameter version of the EPM to match the parameter version of the drive.
dF	Dynamic Braking Fault: The drive has sensed that the dynamic braking resistors are overheating and shuts down to protect the resistors.
EF	External Fault: One of the TB-13 terminals is set as an External Fault input and that terminal is open with respect to TB-11. Refer to Parameters 10, 11 and 12.
GF	Data Fault: User data and OEM defaults in the EPM are corrupted.
HF	High DC Bus Voltage Fault: Line voltage is too high; Deceleration rate is too fast; Overhauling load. For fast deceleration or overhauling loads, dynamic braking may be required.
JF	Remote Keypad Fault: The communication link between the drive and the optional Remote Keypad has been lost. Check for proper wiring and/or noise.
LF	Low DC Bus Voltage Fault: Line voltage is too low.
OF	Output Transistor Fault: Phase to phase or phase to ground short circuit on the output; Boost settings are too high; Acceleration rate is too fast; Failed output transistor.
PF	Current Overload Fault: VFD is undersized for the application; Mechanical problem with the driven equipment.
UF	Start Fault: Start command was present when the drive was powered up. Must wait 2 seconds after power-up to apply Start command if START METHOD is set to NORMAL.
F1	EPM Fault: The EPM is missing or damaged.
FC, F2 - F9, Fo	Internal Faults: The control board has sensed a problem - consult factory.

To clear a fault, issue a STOP command on the terminal strip. The fault will only clear if the condition that caused the fault has passed. For example, if the drive trips on a LOW DC BUS VOLTAGE FAULT (LF) due to low input voltage, the fault cannot be cleared until the input voltage returns to a normal level.

If the drive is programmed to automatically restart after a fault (see Parameter 03), the drive will attempt to restart three times after a fault (the drive will not restart after CF, cF, GF, FC, F1, F2-F9, or Fo faults). If all three restart attempts are unsuccessful, the drive will trip into FAULT LOCKOUT (LC), which requires a manual reset as described above.

## 17.0 SCL/SCM DISPLAY MESSAGES

The following describes the various displays and messages that can appear on the SCL/SCM drive.

### 17.1 SPEED DISPLAY

If the drive is in a STOP state (indicated by "- -" on the display), and the commanded speed is changed, the display will show the commanded speed, and the upper left decimal point will turn on solid. About five seconds after a change is made, the display will begin to alternate between the commanded speed value and the "- -" display. If the **Mode** button is pressed, the display will stop alternating and show the "- -" display only.

When the drive is given a START command, the displayed speed will start increasing as the drive accelerates up to the commanded speed. If the commanded speed is changed while the drive is running, the display will show the commanded speed rather than the actual speed, until the actual speed reaches the commanded speed.

If the commanded speed is changed faster than the drive can accelerate or decelerate, the upper left decimal point will blink to indicate that the the drive is accelerating or decelerating to the new speed. Once the actual speed reaches the commanded speed, the upper left decimal point will turn on solid for 5 seconds and then turn off to indicate that the commanded speed has been reached, and that the display is now showing the actual speed.

### 17.2 CHANGING THE SPEED REFERENCE SOURCE

When the speed source is changed while the drive is running, the display will flash the message for the new speed source to indicate that the new speed source is active. Also, if the drive is being controlled from a speed source other than the ▲ and ▼ buttons (0-10 VDC, 4-20 mA, etc), and one of the ▲ or ▼ buttons is pressed, the display will flash the present speed source message to indicate that the ▲ and ▼ buttons are invalid.

**Example 1:** The drive is running and the present speed source is the keypad. TB-13A is programmed to select a 4-20 mA signal as the speed source. When TB-13A is closed to TB-11, the display will flash "EI" to indicate that the speed source has changed to the 4-20 mA signal. If the contact between TB-13A and TB-11 is opened, the display will flash "CP" to indicate that the speed source has changed back to the ▲ and ▼ buttons.

**Example 2:** The speed source is a 0-10 VDC signal. If the ▲ or ▼ button is pushed, the display will flash "EU" to indicate that the present speed source is the 0-10 VDC signal and that the ▲ and ▼ buttons are invalid.

Refer to the table below for the possible speed reference source displays:

<b>SPEED SOURCE DISPLAYS</b>	
<b>DISPLAY</b>	<b>DESCRIPTION</b>
CP	CONTROL PAD: Speed is set using the ▲ and ▼ buttons on the front of the drive.
EI	EXTERNAL CURRENT: Speed is controlled by a 4-20 mA signal wired to TB-25 and TB-2.
EU	EXTERNAL VOLTAGE: Speed is controlled by a 0-10 VDC signal wired to TB-5 and TB-2.
JG	JOG: The drive is in Jog mode, and the speed is set by Preset Speed #2 (Parameter 32).
OP	MOP (Motor Operated Pot): Contacts wired to TB-13B and TB-13C are used to increase and decrease the drive speed.
Pr1 - Pr7	PRESET SPEEDS #1-7: Speed is set by the indicated Preset Speed (Parameters 31-37).

**NOTE:** The speed source displays will flash when the speed reference source is changed while the drive is running to indicate that the new speed reference source is active.

### 17.3 STATUS AND WARNING MESSAGES

<b>STATUS AND WARNING MESSAGES</b>	
<b>DISPLAY</b>	<b>DESCRIPTION</b>
br	DC BRAKING: The DC braking circuit is activated.
cE	"cE" will be displayed if an EPM with a different parameter version is installed and then an attempt is made to change parameter settings without performing the TRANSLATE function. Refer to PROGRAM SELECTION (Parameter 48).
CL	CURRENT LIMIT: The output current has exceeded the CURRENT LIMIT setting (Parameter 25) and the drive is reducing the output frequency to reduce the output current. If the drive remains in CURRENT LIMIT for too long, it can trip into a CURRENT OVERLOAD fault (PF).
Er	ERROR: Invalid data has been entered or an invalid command was attempted.
GE	"GE" will be displayed if an attempt is made to change the OEM default settings when the drive is operating in the OEM mode (see Parameter 48).
GF	If "GF" is displayed when a RESET OEM is attempted, it indicates that the OEM defaults in the EPM are corrupted. If "GF" is displayed upon power-up, it indicates that the OEM defaults and the user settings in the EPM are corrupted. Refer to Section 13.2.
LC	FAULT LOCKOUT: The drive has failed three restart attempts and now requires manual reset.
SE	SERIAL: The optional remote keypad is active as the user interface instead of the buttons on the front of the drive. See Parameter 14 - CONTROL.
SP	START PENDING: "SP" blinks during the interval between restart attempts.
✕ ✕	DECEL OVERRIDE (both upper decimal points blinking): The drive has stopped decelerating to avoid tripping into an HF fault due to regenerative energy from the motor.