



**CRITTENDEN CONVERSION CORPORATION**  
**MOSES LAKE, WASHINGTON**

## **VACUUM BRIDGE GUIDE 2001**



## Table of Contents

System Overview.....	4
Before Start .....	7
SYSTEM SETUP .....	8
Vacuum adjustment procedure.....	9
BG 2001 Operation .....	11
Troubleshooting .....	18
PLC DIGITAL INPUTS.....	20
PLC ANALOG INPUTS .....	21
PLC DIGITAL OUTPUTS .....	21
ANALOG OUTPUTS.....	22
POWER BUDGET .....	23
Keys .....	24
SCREENS.....	26
Screen #1 .....	26
Screen #2 .....	27
Screen #3 .....	28
Screen #4.....	30
Screen #5 .....	32
Screen #6 .....	33
Screen #7 .....	34
Screen #8 .....	35
Screen # 10 .....	37
Screen #11 .....	38
Screen #12 .....	39
Screen #13 .....	41
Screen #14 .....	42
Screen #15 .....	43
Screen #16 .....	45
Screen #17 .....	46
Screen #18 .....	47
Screen #19 .....	48
Screen #20 .....	49
Screen #21 .....	49
Screen #22 .....	50
Screen #23 .....	52
Screen #24 .....	52
Screen #25 .....	54
Screen #26 .....	55
Screen # 27 .....	56
Screen #30 .....	57
Screen #31 .....	58
Screen #32 .....	60
Screen #33 .....	61
Screen #34 .....	63
Screen #35 .....	65
Screen #41 .....	66
Screen #42 .....	67
Screen #43 .....	69
Screen #44 .....	70
Screen #45 .....	71
Screen #46 .....	72
Screen #47 .....	73
Screen #48 .....	74
HELP SCREENS.....	75
Screen #400 .....	75

Screen#403 .....	75
Screen #404 .....	75
Screen #405 .....	75
Screen #406 .....	76
Screen #407 .....	76
Screen #408 .....	76
Screen #410 .....	76
Screen #411 .....	76
Screen #413 .....	77
Screen #414 .....	77
Screen #415 .....	77
Screen #417 .....	77
Screen #419 .....	78
Screen #420 .....	78
Screen #425 .....	78
Screen #426 .....	78
Screen #427 .....	79
Screen #428 .....	79
Screen #431 .....	79
Screen #433 .....	79

#### SCHEMATIC DIAGRAMS

- 1 BG1 CONTROL PANEL 3-PHASE SCHEMATIC
- 2 BG1 CONTROL PANEL 120VAC TO 24/12 VDC DISTRIBUTION
- 3 BG1 CONTROL PANEL PLC INPUTS MAIN MODULE
- 4 BG1 CONTROL PANEL VACUUM CONTROL SWITCHES SCHEMATIC
- 5 BG1 CONTROL PANEL EXTENSION MODULES INPUTS SCHEMATIC
- 6 BG1 CONTROL PANEL OUTPUTS SCHEMATIC  
Extension module EM 235-OKD22-0XA0 AI4/AO Configuration Switch

#### Settings

- 7 BG1 CONTROL PANEL TERMINAL STRIP WIRING SCHEMATIC
- 8 BG1 CONTROL PANEL BOX#1 TERMINAL STRIP WIRING SCHEMATIC
- 9 BG1 BLOWER 3-PHASE SCHEMATIC
- 10 MODEL MAR 8RH-8 120 50/60 0.6 AMP (VACUUM MORE/LESS)
- 11 BG-2001 - Vacuum Unit
- 12 DC-DC CONVERTER 24VDC/12VDC-VR-2002/12/10

#### ASSEMBLING DIAGRAMS

- 1 CONDUITS AND JUNCTION BOXES
- 2 CABLES
- 3 JUNCTION BOX #1
- 4 MANUAL MOVE REMOTE CONTROL BOX
- 5 JUNCTION BOX#3
- 6 JUNCTION BOX#6
- 7 BG1 CONTROL PANEL FRONT INSIDE WIRING

#### VARIABLE FREQUENCY DRIVE SM410 PARAMETER TABLE OIT TROUBLESHOOTING

## System Overview

The bridge guide 2001 control system has been designed to provide automatic and manual opening width changing control for a single bridge guide station.

Guides are moved with 1/2 HP motor. Variable Frequency Drive (VFD) is used to drive the motor with two different speeds low and high. Positioning feedback information comes from the hollow shaft quadrature encoder, which sends impulse sequences to the Programming Logic Controller (PLC). The PLC is used for processing these sequences and providing control signals to move and stop guides at desired positions.

The blower unit with a 5 HP motor is used as a vacuum source for both vacuum chambers. MORE-LESS vacuum motor controls the level of vacuum in the vacuum chamber. One solenoid allows vacuum quick dump.

Operators can read and change vacuum and current position values for the station from the Operator Interface Terminal (OIT) screen, guides may be moved using manual switch on the Main and Remote panel.

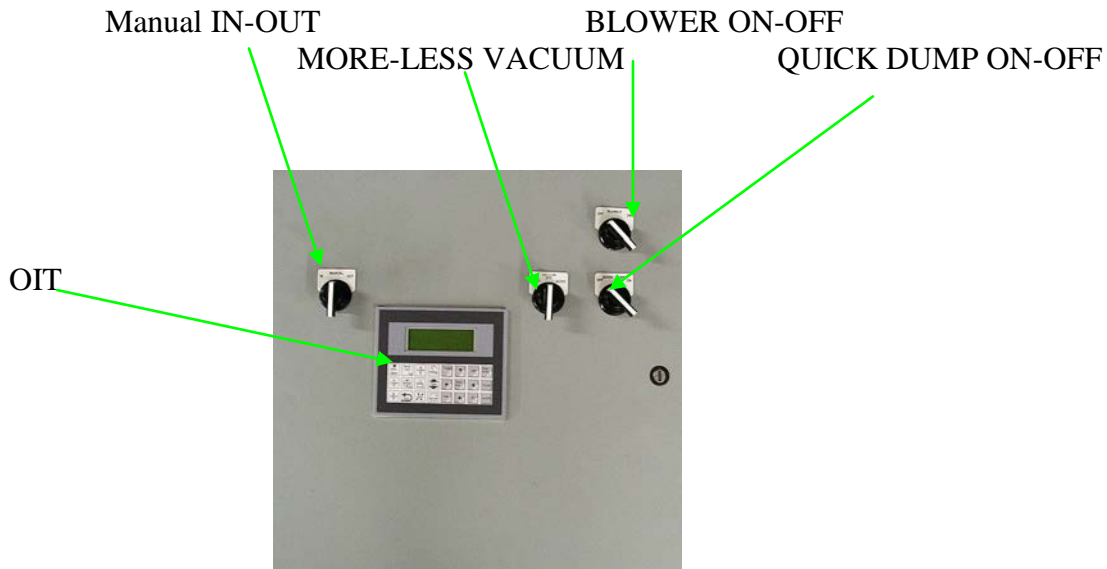

**Figure 1. Main Panel front view**

Additional “Manual IN-OUT” switch locates on the opposite BLOWER side of the bridge to provide manual positioning control for the operator.

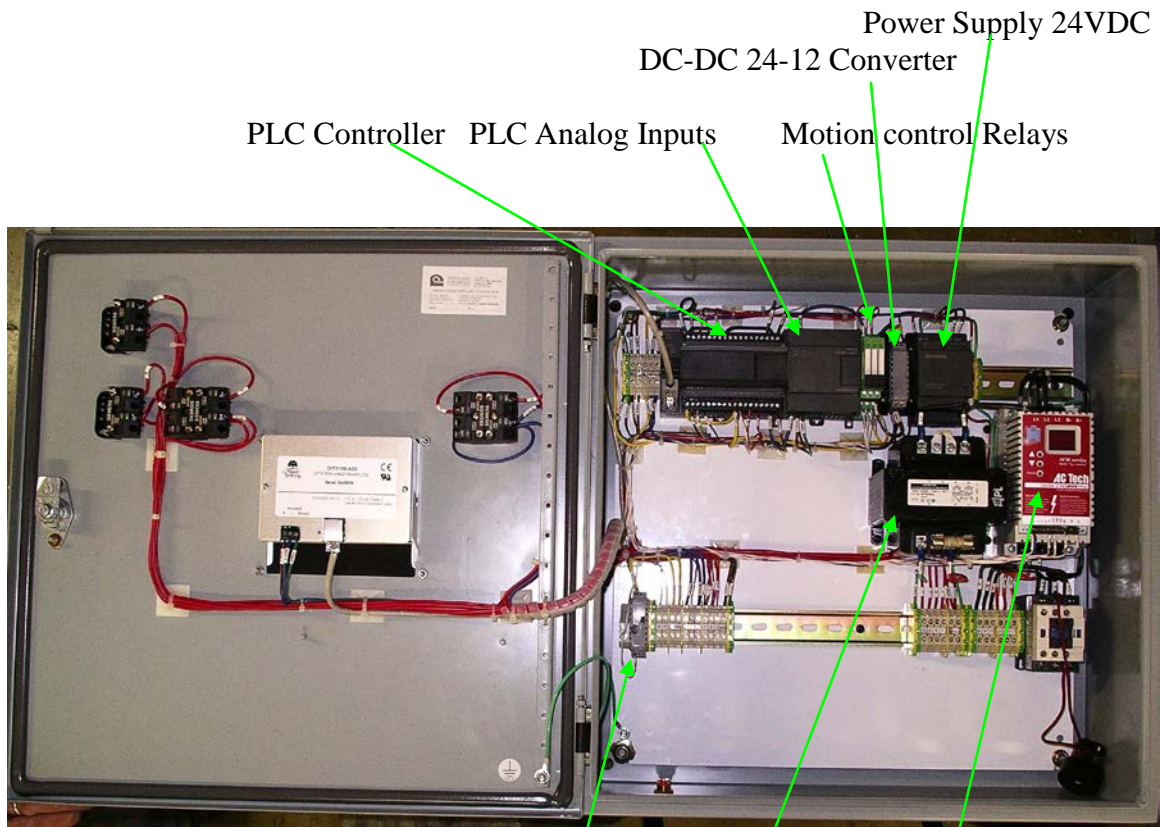

Power Supply 24VDC  
 DC-DC 24-12 Converter  
 PLC Controller   PLC Analog Inputs   Motion control Relays

**Figure 2. Main Panel inside view.**

Vacuum Sensor  
 Step down Transformer  
 460-120VAC                      VFD

**Figure 2. Main Panel inside view**

### Diagram of System Configuration

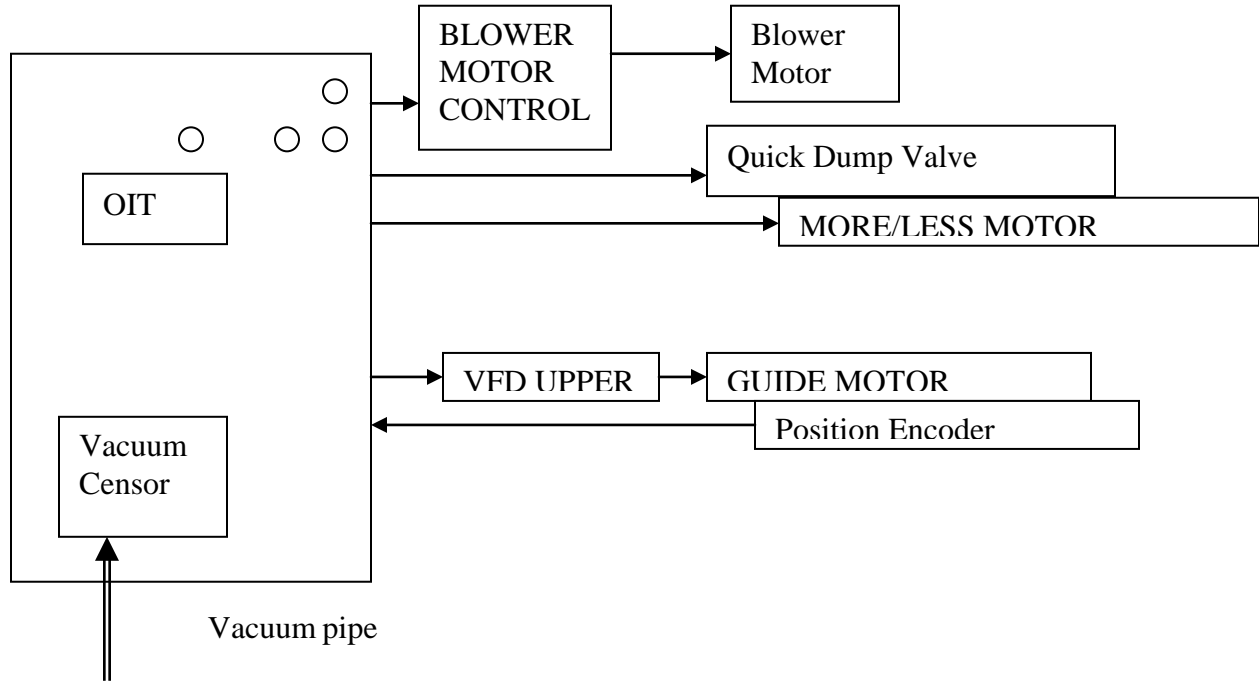

Figure 3. Diagram of System Configuration







## **Before Start**

1. Connect 3 phase 480VAC from the 10 AMP source to the inputs (L1, L2, L3) mechanically activated contactor in the Main panel. Run all high voltage wires separate from the low voltage and control wires.
2. Close the panel and make sure door is closed tightly.
3. After the introduction logo message appears on the Operator Interface Terminal (OIT) screen, turn “Blower ON/OFF” switch ON.
4. Check rotational direction of Blower. Swap the input two power wires if wrong.
5. Use “Manual IN/OUT” switch for the station to move guides from the limit switches into the working area (Trip Arm is located between two limits). Check for the correct motion direction. Swap wires on the motors if wrong.
6. Guides must stop when they reach limit switches. Check limit switches (Normally Closed) and wiring if guides do not stop.

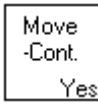
## SYSTEM SETUP

1. Make sure that Guides are locating in the working area (Trip Arm is located between limit switches). If not move them manually or use “Manual IN/OUT” switches.

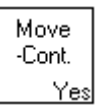
**Attention!!! Do not try “Move home” until you make sure that the Guides are located between limit switches and Limit switches properly wired and tested.**

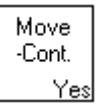
2. Push “Home” key. 
    - On the message “Home? “ Select “Yes” 
    - To Stop Guide movement push “Stop” key  or 
    - On message “Maximum width” enter measured width values for all stations (values can be **Metric** or **English**).
    - Push Enter 
    - Push Yes 
    - On message “Minimum width” enter measured width values for all stations (values can be **Metric** or **English**).
    - Push Enter 
    - Push Yes 
3. System is ready. Numbers are now saved into the memory. Switching power OFF/ON does not change them. (It is possible to lose that setting if system remains OFF for more than 6 months.)



## Vacuum adjustment procedure

- 1) Push button 

On the screen you will see



- 2) Push  - Yes



- 3) Enter password 0000

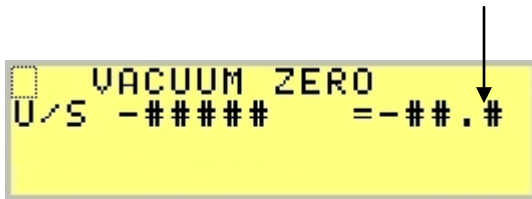

Turn off Blower.

On the screen you will see

Current Vacuum Readings



- 4) Use  and  to Increase or Decrease Zero adjustment numbers

Or Push  and enter numbers, and then Push 

- 5) Change numbers until Current readings equal zero

6) Push 

Turn ON Blower and put paper on the vacuum chambers. Use vacuum meter gage to compare with readings.

On the screen you will see

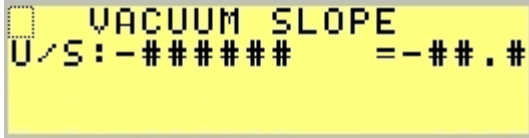
7) 

- 8) Adjust slope similar with procedure described above. Use “More-Less” vacuum adjustments to set values in maximum (~15-20) and medium (~7-10).
- 9) Return to the previous screen and repeat ZERO adjustment if it’s necessary.

## BG 2001 Operation

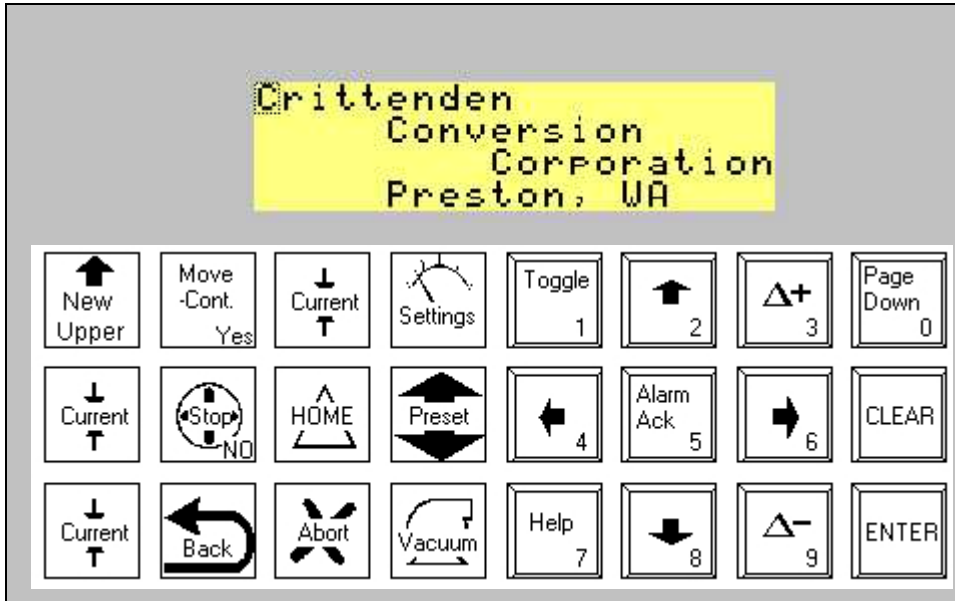

### 2. Get Help



- Push and hold "Help" key
- Read Help screen

### 3. See current Width (values can be Metric or English).

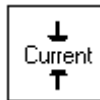

- Push "Current" key

### 4. See current Vacuum readings.

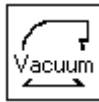

- Push "Vacuum" key.



### 5. Enter New Upper station width(values can be Metric or English)..



- Push "New Upper" key;



- Push "Clear",
- Enter numbers (for example: 44.5 > 4, 4, 5)



- Push "Enter" 
- Push "Yes" 

### 6. Move to the new width.





- Push "Move" 
- Check numbers on the screen "from 44.5 to 75.2"





- Push "Move" 

### 7. Stop when moving.



- Push "Stop" 
- On the message "Continue or Back" select "Move"  or "Back" 

### 8. Move Home.



- Push "Home" key. 
- On the message "Home?" Select "Yes"  or "NO" 
- You can stop any time to push "Stop" key. 
- On message "Maximum width" enter measured width values for all stations

- Push Enter 
- Push Yes 
- On message “Minimum width” enter measured width values for all stations. Push Enter 
- Push Yes 



**9. Abort motion and operation – Reset controller.**





- Push “Abort”  or Turn power Off
- On message “Abort everything?” select “Yes”. 

**10. Change settings. (Vacuum scale and slope, distance before speed slow down, demo mode)**

- Push “Settings” key 
- On the message “Are you sure to change settings?” select “Yes”, 
- Enter password 0000,
- Change settings

**11. Change Preset.**

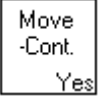
- Push “Preset” key. 
- Push “clear”, 
- Enter new preset value.
- Push Enter 

- Push "Page Down" 
- On the message "Assign to new Upper Width?" Select "Yes"  or "No" 
- On message "Assign to new Lower Width?" select "Yes"  or "No" 
- ..... "Swap Upper new and Lower new"
- ..... "Assign to Upper new to lower new?"
- ..... "Assign to Lower new to Upper new?"

## 12. Stop Alarm

- Push "Alarm Acknowledgment" 

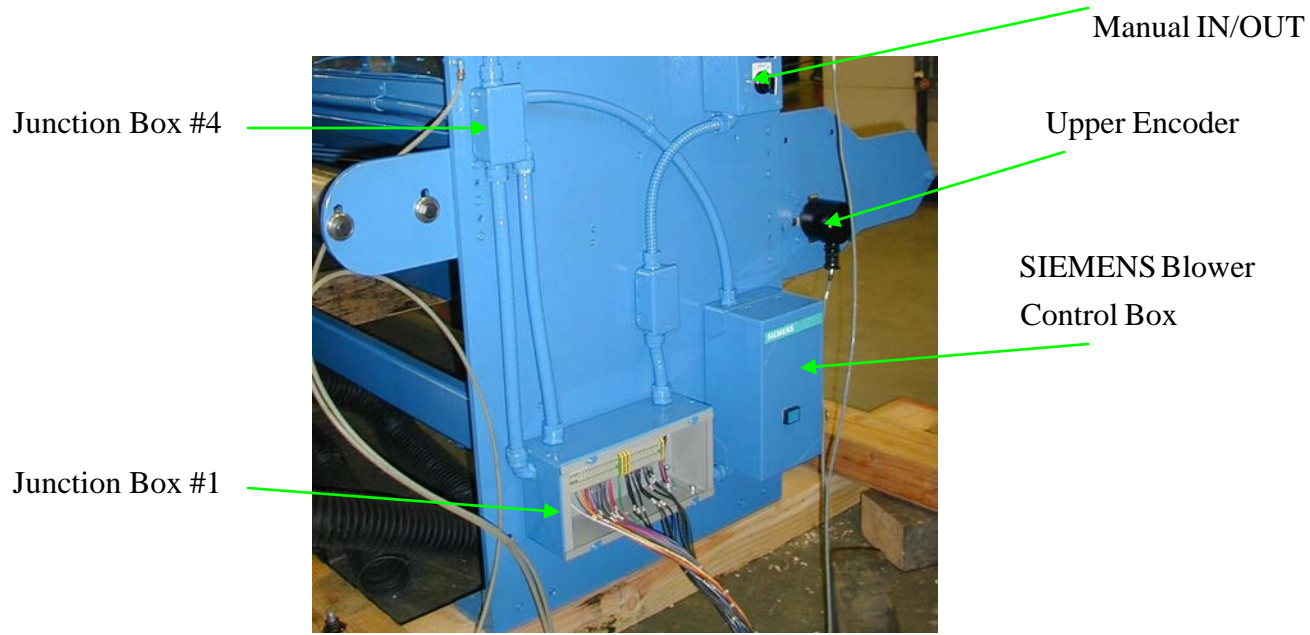

**Figure 4. Manual switches side.**

### Station Limit Switches

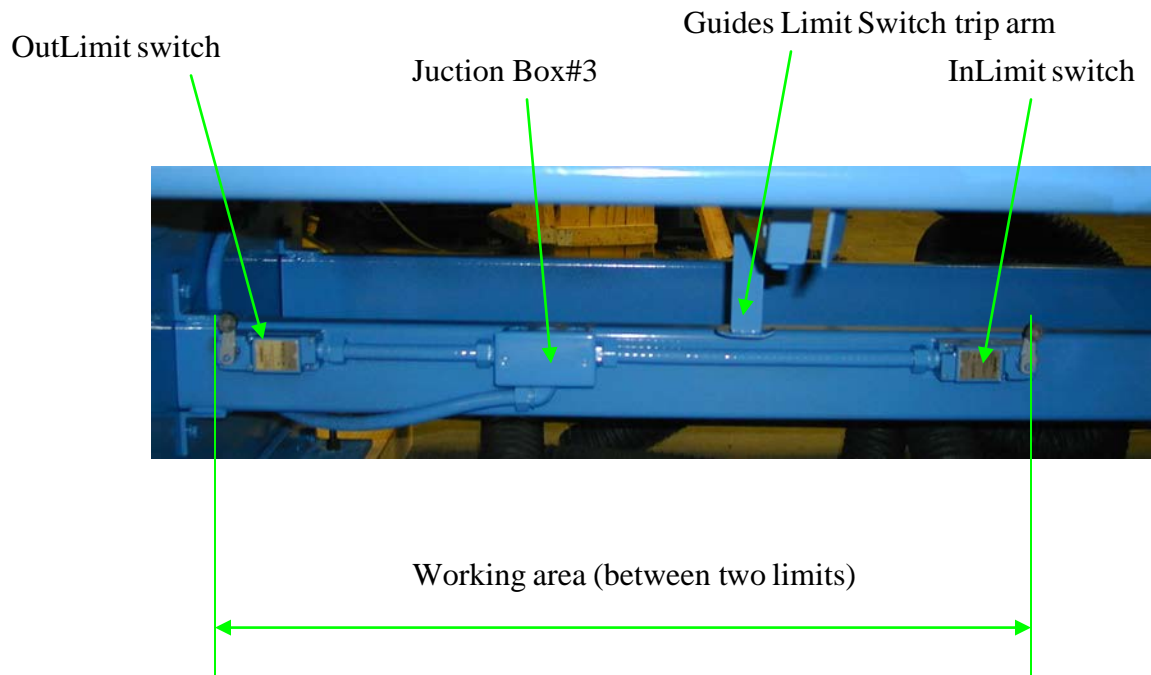
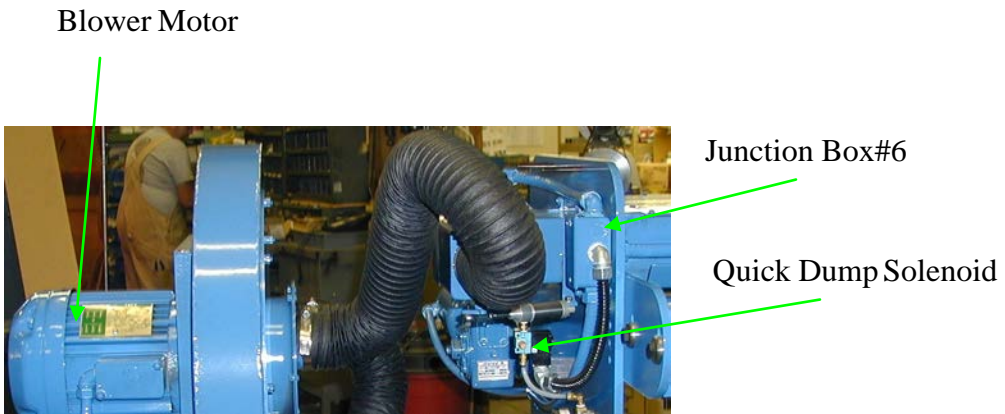

Figure 4. Limit Switches





**Figure 5. Blower side**



**Figure 6. Blower**

## Troubleshooting

ACTION	SCREEN/SYSTEM	POSSIBLE SOURCE OF PROBLEM	SOLUTION
System power on	The OIT screen is dark and -Manual IN and OUT does not work	No power 440VAC or 110 VAC No power 24 VDC.	Check the main panel door Is it completely closed? Check 440/110 Vac. Check the fuses in the main panel. Check 24 Vdc from the power supplies in the main panel.
System power on	The OIT screen is dark and -Manual IN and OUT does work	No power to OIT.	Check wires from terminal to the OIT in the main panel.
System power on	Error message on the OIT screen	Read message and follow recommendation on the screen and HELP screen.	Read message and follow recommendation on the screen
No motion	No messages	- Corresponding Control relays failed - VFD failed	Open main panel Power up manually and check error code from the VFD display. Check corresponding relays cause of the problem.
Checking vacuum	Readings “00” does not changing when using More or Less switch Blower working properly.	There is no paper. Vacuum pipe is not on vacuum sensor or bad sensor.	Check fuse or 12 DC on the sensor’s terminals. Install pipe or replace pipe or sensor
Start Blower	Blower starts but no vacuum	- No paper - Wrong rotational direction	- Put paper - Swap 2 input power wires
Start Blower	Blower does not start.	Overload protection relay turned off. No 460 VAC 3Phase power.	Push reset on the Blower control panel. Check 460 VAC 3 Phase power source.

Start More-Less	More-Less does not work	No power 110 VAC from the main panel or switch or “more less” motor does not work	Check power 110 VAC from main panel to the More-less switch and to the More-less motor
Start motion	Guides move into wrong direction	Wrong 3 phase power phasing	Swap two input 3 phase power wires on the corresponding motor.
Start motion	Numbers move in wrong direction	Wrong encoder phasing	Swap A and B channel encoder wires.
Start motion	Screen show motion screen but no any motion	- Check next width numbers for out limit values. - Check VFDs for possible errors	- Reenter correct next width -Open main panel. Power up and check for error messages on VFDs.

### PLC DIGITAL INPUTS

INPUTS	Device	Wires #	PLC ADDRESS
Upper station Positioning Encoder Pulses	Upper Encoder Ch A Ch B	A B	I0.0 I0.1
Upper station Manual IN	Switch Upper Manual In/Out	1	I0.2
Upper station Manual OUT	Switch Upper Manual In/Out	2	I1.4
Upper station LIMIT switch	Upper Limit switches	3	I1.2
Upper Drive Fault	VFD Upper	UF	I1.0

### PLC ANALOG INPUTS

INPUTS	Device	Wires##	PLC ADDRESS
Vacuum sensor Upper	Vacuum sensor UP/PLC Analog Inputs module	A+	AIW4

### PLC DIGITAL OUTPUTS

OUTPUTS	Device	Wires #	PLC ADDRESS
Upper move Out	Relay Uout/VFD Upper	UOUT	Q0.0
Upper move IN	Relay Uin /VFD Upper	UIN	Q0.2
Upper slow motion	Relay Uslow/ VFD Upper	USL	Q0.4

## ANALOG OUTPUTS

Outputs	Control	Device	Wires##	VOLTAGE
Upper more vacuum	Upper more/less switch	Upper more/less motor	4	110VAC
Upper less vacuum	Upper more/less switch	Upper more/less motor	5	110VAC
Upper Quick dump	Upper Quick dump switch	Upper quick dump valve	6	110VAC
Blower ON/OFF	Blower Switch ON/OFF	Blower contactor	7	110VAC

## POWER BUDGET

### SINGLE Station

System power Budget		440VAC		10 Amp source
System requirements:	Units Number	Amps per unit	Total amps	
Transformer 440/110	1	0.5	0.5	
VFD drives	1	1.4	1.4	
Blower motor 5 hp 6.2 Amp 460VAC	1	6.2	6.2	
Total (A)=			8.1	

24VDC Power Budget		24VDC		
Power supply on CPU	<b>0.28 Amp</b>		No fuse	
System requirements	Units Number	Amps per unit	Total amps	
6 relays (outputs)	3	0.007	0.021	
Total (A)=			0.021	

Power supply External	<b>1.3 Amp</b>		Fuse inputs 1.5 AMP	
System requirements	Units Number	Amps per unit	Total amps	
OIT	1	0.1	0.1	
DC/DC 24/12VDC	1	0.15	0.15	
CPU 224	1	0.9	0.9	
Extension Module EM235	1	0.06	0.06	
Total (A)=			1.21	

110VAC				
Power supply	<b>2.02 Amp</b>		FUSE 3 AMP	
System requirements	Units Number	Amps per unit	Total amps	
110/24 power supply	1	0.48	0.48	
Blower starter	1	0.8	0.8	
More/less vacuum motor	1	0.6	0.6	
Quick Dump solenoid	1	0.06	0.06	
Total(A)=			1.94	

12 VDC				
Power supply	<b>1 Amp</b>		Fuse 1 amps	
System requirements	Units Number	Amps per unit	Total amps	
Encoder	1	0.025	0.025	
12 inputs	4	0.004	0.016	
Vacuum sensor	1	0.01	0.01	
Total (A)=			0.051	

## Keys

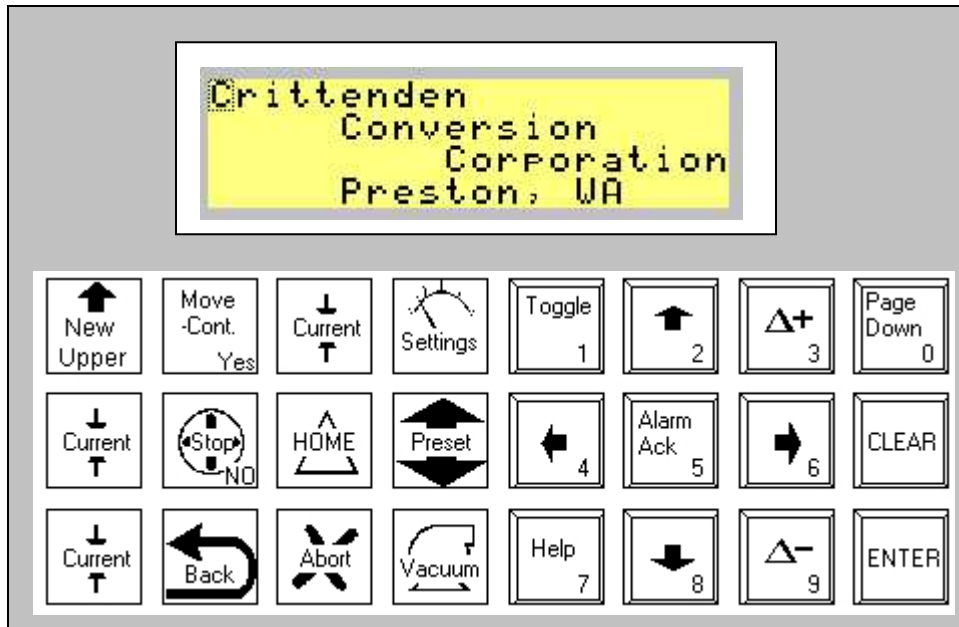

- Activate Home Procedure



- Enter NEW WIDTH for UPPER STATION

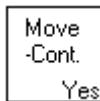

- Start Move or Continue or YES



- STOP MOTION or NO



- Move back to previous position

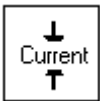

- Show current for UPPER and LOWER STATIONS



- ABORT all operation and reset controller



- Change settings (Password protected)





- Change preset and set preset

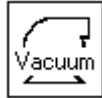

- Show vacuum values for UPPER and LOWER stations



- Get HELP on screen

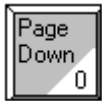

- Scroll available screens



- Clear value



- Enter value



- 3 or Increment value



- 9 or Decrement value



- 5 or alarm acknowledgement



- 2 or cursor UP



- 4 or cursor LEFT



- 6 or cursor RIGHT



- 8 or cursor DOWN



- 1 or Toggle ON/OFF settings

# SCREENS

## Screen #1

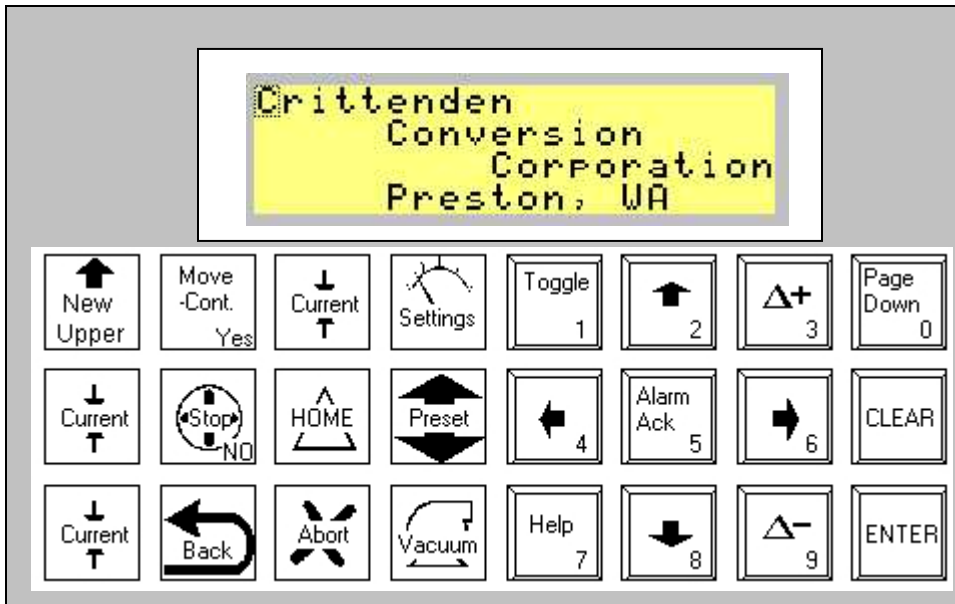

### Screen Type:

Message

Start Up Screen

### Control Buttons.

SDF8



- OPEN screen #17 "Move Home?"

No password

### Chain screen.

Automatically go to the Screen #2 "Bridge Guide 2003 "

### Time showed.

2 sec

### Help screens.

Screen # 400

## Screen #2

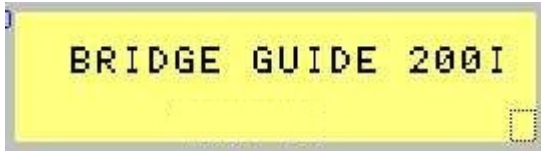

**Screen Type:**

Message

**Control Buttons.**



- Open Screen #17 "Move Home?"

No password

**Chain screen.**

Automatically go to the Screen #3 "Information 800-755-7894"

**Time showed.**

5 sec

**Help screens.**

Screen # 400

### Screen #3

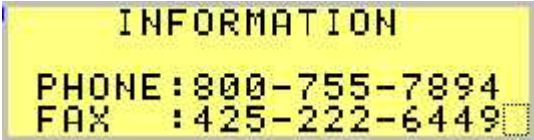

**Screen Type:**

Message

**Control Buttons.**

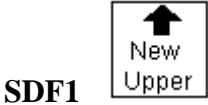

Screen #4 "Upper new Width?"

No password

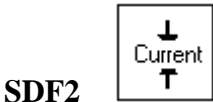

Open Screen # 34 "Current Width"



Screen # 23 "Low station new width"

No password



Open Screen # 34 "Current Width"

No password



Open Screen # 17 "HOME"



Open Screen # 1 "Start UP"



**SDF7**  
Open Screen # 34 "Current Width"



**SDF8**  
- Screen #17 "Move Home?"  
No password  
**Chain screen.**  
Automatically go to the Screen #22 "Current WIDTH"  
**Time showed.**  
**20 sec**  
**Help screens.**  
Screen # 400

# Screen #4

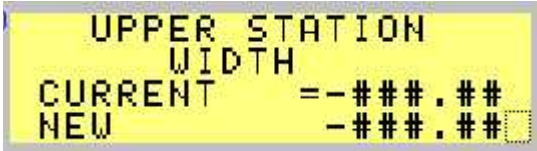

**Screen Type:**

Message

**Control Buttons.**

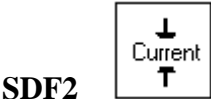

Open Screen # 34 "Current Width"  
No password



Screen # 23 "Low station new width"  
No password



Open Screen # 31 "Move from to "  
No password



Open Screen # 34 "Current width"



Open Screen # Screen # 34 "Current width"



**SDF7**  
Open Screen # 34 "Current Width"



**SDF8**  
- Screen #17 "Move Home?"  
No password

**Chain screen.**  
Screen #34 "Current Width"  
**Time showed.**  
**60 sec**  
**Help screens.**  
Screen # 404

## Screen #5



**Screen Type:**  
Message Screen

**Sound**

**Beep**

**Control Buttons.**

**SDF1** A square button with a black border. At the top is a black upward-pointing arrow. Below the arrow, the word "New" is on the top line and "Upper" is on the bottom line, both in a black, monospaced font.

Screen #4 "Upper new Width?"  
No password

**SDF7-** A square button with a black border. At the top is a black downward-pointing arrow. Below the arrow, the word "Current" is centered in a black, monospaced font. **Open Screen # 34 "Current Width"**

**SDF8** A square button with a black border. At the top is a black upward-pointing arrow. Below the arrow, the word "HOME" is centered in a black, monospaced font. At the bottom is a black downward-pointing arrow.

- Screen #17 "Move Home?"  
No password

**Chain screen.**  
#4 "New Upper Width"

**Time showed.**

**10 sec**

**Help screens.**

No



## Screen #6

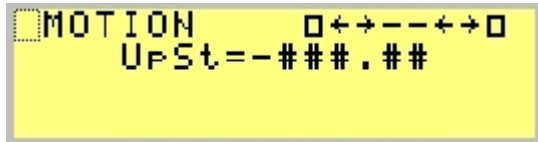

**Screen Type:**

Message

**Control Buttons.**



Stop motion



**Back motion**

**Chain screen.**

No

**Time showed.**

No

**Help screens.**

#406

**Screen #7**





**Screen Type:**  
Message

**Control Buttons.**

**SDF4**   
Continue Motion

**SDF5**   
Open Screen # 34 "Current Width"

**SDF6**   
Return to privies position

**SDF7**   
Open Screen # 34 "Current Width"

**SDF8** 

- Screen #17 "Move Home?"

**Chain screen.**

No

**Time showed.**

No

**Help screens.**

#407

# Screen #8



**Screen Type:**

Message

**Control Buttons.**

**SDF1**

Screen #4 "Upper new Width?"

No password

**SDF2**

Open Screen # 34 "Current Width"

No password

**SDF3**

Open Screen # 34 "Current Width"

No password

**SDF4**

Enter Preset

No password

**SDF5**

Open Screen # 34 "Current Width"

**SDF6**

Open Screen # 34 "Current Width"

**SDF7-**

Open Screen # 34 "Current Width"



- Screen #17 "Move Home?"

**Chain screen.**

Forward #55

Backward #33

**Time showed.**

No

**Help screens.**

No

## Screen # 10



**Screen Type:**

Message

**Sound .**

Beep.

**Control Buttons.**



**SDF8**

Screen #17 "Move Home?"

No password

**Chain screen.**

Screen #17

**Time showed.**

255 sec

**Help screens.**

410

## Screen #11



**Screen Type:**

Message

**Sound .**

Beep.

**Control Buttons.**



Screen #17 “Move Home?”

No password

**Chain screen.**

Screen #17

**Time showed.**

**Help screens.**

#411

## Screen #12

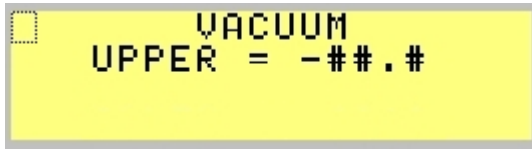

### Screen Type:

Message

Sound .

No

### Control Buttons.



Screen #4 "Upper new Width?"

No password

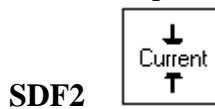

Open Screen # 34 "Current Width"

No password

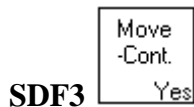

Open Screen # 34 "Current Width"

No password



Open Screen # 34 "Current Width"

No password



Open Screen # 34 "Current Width"

No password



Open Screen # 34 "Current Width"

No password



Open Screen # 34 "Current Width"



- Screen #17 "Move Home?"

No password

**Chain screen.**

Forward #34,

Backward #

**Time showed.**

**Help screens.**



## Screen #13



**Screen Type:**

Message

**Sound .**

Beep

**Control Buttons.**



SDF8

Screen #17 "Move Home?"

No password

**Chain screen.**

No

**Time showed.**

No

**Help screens.**

#413

## Screen #14



**Screen Type:**  
Message

**Sound .**  
No

**Control Buttons.**



**SDF4**  
Screen #17 "Move Home?"  
No password



**SDF5**  
**DEMO continue**

**Chain screen.**

**Time showed.**  
sec

**Help screens.**  
#414

## Screen #15

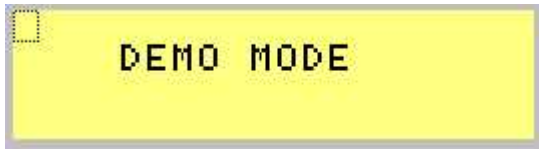

### **Screen Type:**

Message

### **Sound .**

No

### **Control Buttons.**



**SDF1**

Screen #4 "Upper new Width?"

No password

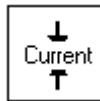

**SDF2**

Open Screen # 34 "Current Width"

No password



**SDF3**

Screen # 23 "Low station new width"

No password

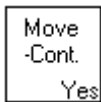

**SDF4**

**Start DEMO**

No password



**SDF5**

Open Screen # 24 "Set all to default"

No password



**SDF6**

Open Screen # 34 "Current Width"

No password



**SDF7**  
Open Screen # 34 "Current Width"



**SDF8**  
- Screen #17 "Move Home?"  
No password  
**Chain screen.**  
FORWARD #24  
BACKWARD #45  
**Time showed 5 sec**  
**Help screens.415**

## Screen #16



**Screen Type:**

Message

**Sound .**

No

**Control Buttons.**



**STOP**

**Chain screen.**

No

**Time showed.**

No

**Help screens.**

No

## Screen #17



**Screen Type:**

Message

**Sound .**

Beep

**Control Buttons.**

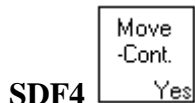

Move Home



Open Screen # 34 "Current Width"



Open Screen # 34 "Current Width"

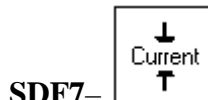

Open Screen # 34 "Current Width"

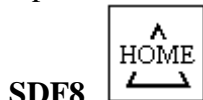

Screen #17 "Move Home?"

No password

**Chain screen.**

No

**Time showed.**

No

**Help screens.**

#417

## Screen #18



**Screen Type:**

Alarm

**Sound .**

Continuous Beep

**Control Buttons.**



**SDF8**

Screen #17 "Move Home?"

No password

**Chain screen.**

No

**Time showed.**

No

**Help screens.**

## Screen #19

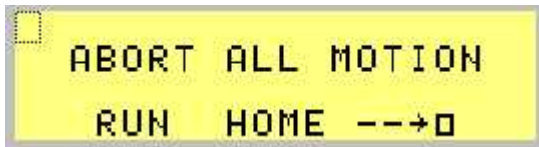

**Screen Type:**

Message

**Sound .**

Beep



**SDF4**

Screen #17 "Move Home?"

No password



**SDF5**

Open Screen # 34 "Current Width "

**Control Buttons.**



**SDF8**

Screen #17 "Move Home?"

No password

**Chain screen.**

17

**Time showed.**

No

**Help screens.**

#419



**Screen #20**  
**Screen #21**



**Screen Type:**

Message

**Sound .**

No

**Control Buttons.**



**SDF5**

**STOP**

**Chain screen.**

No

**Time showed.**

No

**Help screens.**

No

## Screen #22

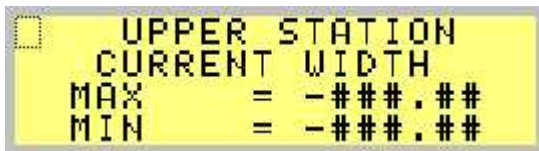

### Screen Type:

Message

Sound .

No

### Control Buttons.



SDF1

Screen #4 "Upper new Width?"

No password

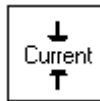

SDF2

Open Screen # 34 "Current Width"

No password



SDF3

Screen # 23 "Low station new width"

No password

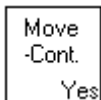

SDF4

### Current width

No password



SDF5

Open Screen # 24 "Set all to default"

No password



SDF6

Open Screen # 34 "Current Width"

No password



**SDF7**  
Open Screen # 34 "Current Width"



**SDF8**  
- Screen #17 "Move Home?"

**Chain screen.**

**Forward #20**

**Backward #3**

**Time showed.**

**5 sec**

**Help screens.**

**#420**

**Screen #23**

**Screen #24**



**Screen Type:**

Message

**Sound .**

No

**Control Buttons.**



**SDF1**

Screen #4 "Upper new Width?"

No password

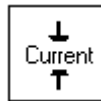

**SDF2**

Open Screen # 34 "Current Width"

No password



**SDF3**

Screen # 23 "Low station new width"

No password

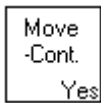

**SDF4**

Start set default values

No password



**SDF5**

Open Screen # 24 "Set all to default"

No password



**SDF6**

Open Screen # 34 "Current Width"

No password

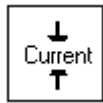

**SDF7**

Open Screen # 34 "Current Width"



**SDF8**

- Screen #17 "Move Home?"

**Chain screen.**

**#47**

**Time showed.**

**20 sec**

**Help screens.**

**#403**

## Screen #25



**Screen Type:**

Message

**Sound .**

**Beep**

**Control Buttons.**



**SDF8**

Screen #17 "Move Home?"

No password

**Chain screen.**

17

**Time showed.**

No

**Help screens.**

#425

## Screen #26

```
□ HOME MinWidth  
MEASURE UP/S:-###.##  
AND  
ENTER
```

**Screen Type:**  
Message

**Sound .**  
Beep

**Control Buttons.**



**SDF4**  
Continue

No password



**SDF8**  
Screen #17 "Move Home?"  
No password

**Chain screen.**  
No

**Time showed.**  
No

**Help screens.**  
#426

## Screen # 27

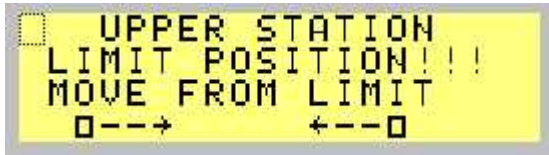

**Screen Type:**

Message

**Sound .**

NO

**Control Buttons.**

**Chain screen.**

**Time showed.**

No

**Help screens.**

427



## Screen #30



**Screen Type:**

Message

**Sound .**

NO

**Control Buttons.**

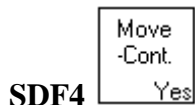

Move

No password



Open Screen # 34 "Current Width"



Open Screen # 34 "Current Width"

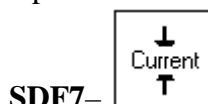

Open Screen # 34 "Current Width"

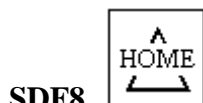

Screen #17 "Move Home?"

No password

**Chain screen.**

NO

**Time showed.**

No

**Help screens. 405**

## Screen #31

```
MOVE FROM → TO?  
U/S=-###.## :-###.##
```

**Screen Type:**

Message

**Sound .**

NO

**Control Buttons.**



**SDF1**

Screen #4 "Upper new Width?"

No password

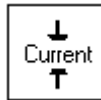

**SDF2**

Open Screen # 34 "Current Width"

No password



**SDF3**

Screen # 23 "Low station new width"

No password

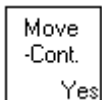

**SDF4**

**Move**

No password



**SDF5**

Open Screen # 24 "Set all to default"

No password



**SDF6**

Open Screen # 34 "Current Width"

No password



**SDF7**  
Open Screen # 34 "Current Width"



**SDF8**  
- Screen #17 "Move Home?"

**Chain screen.**

34

**Time showed.**

No

**Help screens.**

431

## Screen #32



### Screen Type:

Message

Sound .

NO

### Control Buttons.

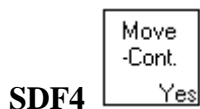

Yes change settings

No password



Open Screen # 34 "Current Width"



Open Screen # 34 "Current Width"

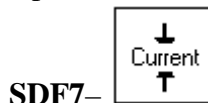

Open Screen # 34 "Current Width"

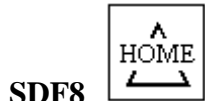

Screen #17 "Move Home?"

No password

### Chain screen.

### Time showed.

No

### Help screens.

## Screen #33

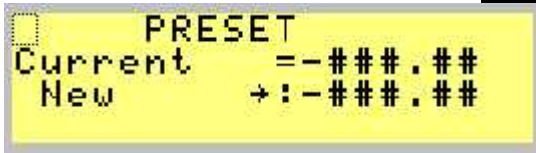

### Screen Type:

Message

### Sound .

NO

### Control Buttons.



SDF1

Screen #4 "Upper new Width?"

No password

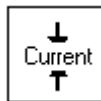

SDF2

Open Screen # 34 "Current Width"

No password



SDF3

Screen # 23 "Low station new width"

No password



SDF4

Continue

No password



SDF5

Open Screen # 24 "Set all to default"

No password



SDF6

Open Screen # 34 "Current Width"

No password

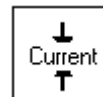

SDF7

Open Screen # 34 "Current Width"



- Screen #17 "Move Home?"

**Forward #8**

**Backward #40**

**Time showed.**

**No**

**Help screens.**

433

## Screen #34

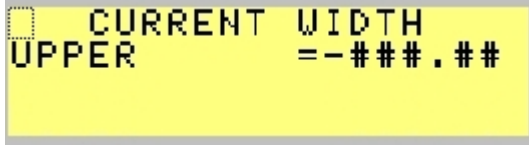

### Screen Type:

Message

### Sound .

NO

### Control Buttons.



#### SDF1

Screen #4 "Upper new Width?"

No password

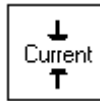

#### SDF2

Open Screen # 34 "Current Width"

No password

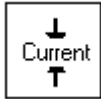

#### SDF3

Open Screen # 34 "Current Width"

No password

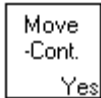

#### SDF4

Move to next widths

No password



#### SDF5

Open Screen # 24 "Set all to default"

No password



#### SDF6

Open Screen # 34 "Current Width"

No password



- Screen #17 "Move Home?"

**Chain screen.**

Forawrd #12

Backward #12

**Time showed.**

**Help screens.**

408



## Screen #35

```
HOME MaxWidth
Measure U/S:-###.##
and ---->
Enter
```

### Screen Type:

Message

### Sound .

Beep

### Control Buttons.

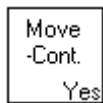

SDF4

YES continue after Max width entered



SDF5

Open Screen # 24 "Set all to default"

No password



SDF6

Open Screen # 34 "Current Width"

No password



SDF8

- Screen #17 "Move Home?"

### Chain screen.

NO

### Time showed.

NO

### Help screens.

NO

## Screen #41

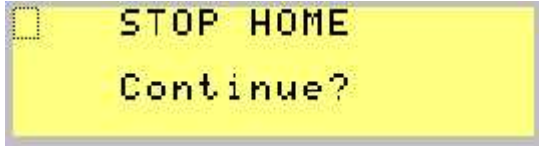

**Screen Type:**

Message

**Sound .**

NO

**Control Buttons.**

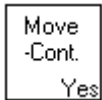

**SDF4**

Yes

No password



**SDF5**

Open Screen # 34



**SDF6**

Open Screen # 17

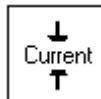

**SDF7-**

Open Screen # 34 "Current Width"



**SDF8**

Screen #17 "Move Home?"

No password

**Chain screen.**

**Time showed.**

No

**Help screens.**

## Screen #42



### Screen Type:

Message

Sound .

NO

### Control Buttons.



**SDF1**

Screen #4 "Upper new Width?"

No password

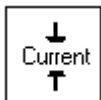

**SDF2**

Open Screen # 34 "Current Width"

No password

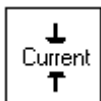

**SDF3**

Open Screen # 34 "Current Width"

No password

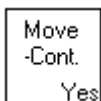

**SDF4**

Vacuum #43

No password



**SDF5**

Open Screen # 24 "Set all to default"

No password



**SDF6**

Open Screen # 34 "Current Width"

No password



**SDF7**

Open Screen # 34 "Current Width"



**SDF8**

- Screen #17 "Move Home?"

**Chain screen.**

#34

**Time showed.**

**No**

**Help screens.**

## Screen #43

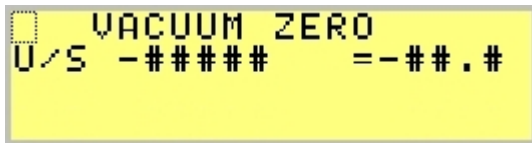

**Screen Type:**

Message

**Sound .**

NO

**Control Buttons.**



**SDF6**

Open Screen # 34

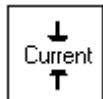

**SDF7-**

Open Screen # 34 "Current Width"



**SDF8**

Screen #17 "Move Home?"

No password

**Chain screen.**

Forward #44

Backward #47

**Time showed.**

No

**Help screens.**

## Screen #44



**Screen Type:**  
Message

**Sound .**  
NO

**Control Buttons.**



**SDF6**  
Open Screen # 34

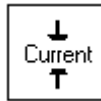

**SDF7-** Open Screen # 34 "Current Width"



**SDF8**  
Screen #17 "Move Home?"  
No password

**Chain screen.**  
Forward #45  
Backward #43

**Time showed.**  
No  
**Help screens.**

## Screen #45



**Screen Type:**

Message

**Sound .**

NO

**Control Buttons.**



**SDF6**

Open Screen # 34



**SDF7-**

Open Screen # 34 "Current Width"



**SDF8**

Screen #17 "Move Home?"

No password

**Chain screen.**

Forward #15

Backward #44

**Time showed.**

No

**Help screens.**

## Screen #46

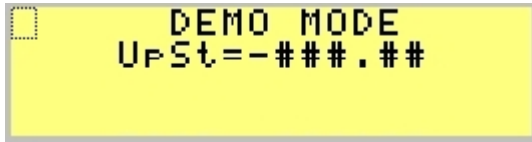

**Screen Type:**

Message

**Sound .**

NO

**Control Buttons.**



**STOP DEMO**

**Chain screen.**

**Time showed.**

No

**Help screens.**



## Screen #47



**Screen Type:**  
Message

**Sound .**  
NO

**Control Buttons.**



- 2 or cursor UP



- 8 or cursor DOWN



- 1 or Toggle ON/OFF settings



**SDF6**  
Open Screen # 34

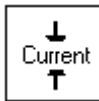

**SDF7-** Open Screen # 34 "Current Width"



**SDF8**  
Screen #17 "Move Home?"  
No password

**Chain screen.**  
Forward #43  
Backward #0

**Time showed.**  
10 sec  
**Help screens.**

## Screen #48



**Screen Type:**

Message

**Sound .**

3 beps

**Control Buttons.**

**Chain screen.**

Forward #43

Backward #0

**Time showed.**

10 sec

**Help screens.**

## HELP SCREENS

### Screen #400

Screen Type:

Help

```
Push "Home" to start  
INFORMATION  
PHONE:800-755-78947
```

### Screen#403

Screen Type:

Help

```
"YES"-Set all to  
Factory Default
```

### Screen #404

Screen Type:

Help

```
Push "Clear" enter New  
width and "Enter"  
Use number keys or  
decrement/increment
```

### Screen #405

Screen Type:

Help

```
"YES"-MoveBack  
"Other Choices"
```

## Screen #406

Screen Type:

Help

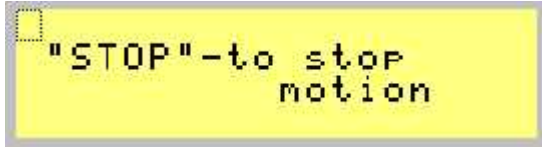

"STOP"-to stop  
motion

## Screen #407

Screen Type:

Help



"Yes"-Continue  
"Back"-Move Back

## Screen #408

Screen Type:

Help



USE ALL F.KEYS  
Page Down-Vacuum

## Screen #410

Screen Type:

Help

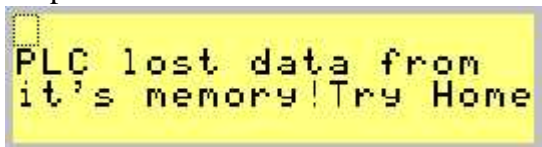

PLC lost data from  
it's memory! Try Home

## Screen #411

Screen Type:

Help

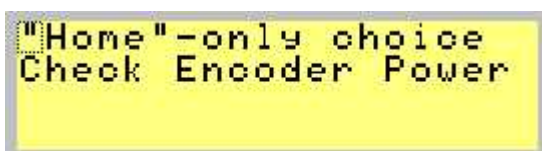

"Home"-only choice  
Check Encoder Power

## Screen #413

Screen Type:

Help

```
Check Drive Error  
Power-Off-Start-Home
```

## Screen #414

Screen Type:

Help

```
"Yes"-Stop "DEMO"  
"No"-Continue "DEMO"
```

## Screen #415

Screen Type:

Help

```
"Yes"-Start "DEMO"
```

## Screen #417

Screen Type:

Help

```
"YES"-StartHome  
"Other choices"
```

## Screen #419

Screen Type:

Help

```
After "Abort" Run  
"HOME" to SetUp Sys.
```

## Screen #420

Screen Type:

Help

```
To change Run Home
```

## Screen #425

Screen Type:

Help

```
PLC lost data from  
it's memory Run Home
```

## Screen #426

Screen Type:

Help

```
Measure and Enter  
correct values
```

## Screen #427

Screen Type:

Help

```
Move guides from  
limit position
```

## Screen #428

Screen Type:

Help

```
Open box and check  
error code on drive
```

## Screen #431

Screen Type:

Help

```
Check values before  
"yes"-to start move
```

## Screen #433

Screen Type:

Help

```
"Yes"-NewPRST+CRNT  
See other Pages+
```

## **APPENDIX**

### ***SCHEMATIC DIAGRAMS***

- 1 BG1 CONTROL PANEL 3-PHASE SCHEMATIC
- 2 BG1 CONTROL PANEL 120VAC TO 24/12 VDC DISTRIBUTION
- 3 BG1 CONTROL PANEL PLC INPUTS MAIN MODULE
- 4 BG1 CONTROL PANEL VACUUM CONTROL SWITCHES SCHEMATIC
- 5 BG1 CONTROL PANEL EXTENSION MODULES INPUTS SCHEMATIC
- 6 BG1 CONTROL PANEL OUTPUTS SCHEMATIC  
Extension module EM 235-OKD22-0XA0 AI4/AO Configuration Switch Settings
- 7 BG1 CONTROL PANEL TERMINAL STRIP WIRING SCHEMATIC
- 8 BG1 CONTROL PANEL BOX#1 TERMINAL STRIP WIRING SCHEMATIC
- 9 BG1 BLOWER 3-PHASE SCHEMATIC
- 10 MODEL MAR 8RH-8 120 50/60 0.6 AMP (VACUUM MORE/LESS)
- 11 BG1-2003 - Vacuum Unit
- 12 DC-DC CONVERTER 24VDC/12VDC-VR-2002/12/10

### ***ASSEMBLING DIAGRAMS***

- 1 CONDUITS AND JUNCTION BOXES
- 2 CABLES
- 3 JUNCTION BOX #1
- 4 MANUAL MOVE REMOTE CONTROL BOX
- 5 JUNCTION BOX#3
- 6 JUNCTION BOX#6
- 7 BG1 CONTROL PANEL FRONT INSIDE WIRING

### **VARIABLE FREQUENCY DRIVE SM410 PARAMETER TABLE OIT TROUBLESHOOTING**



460 VAC 60 Hz 3-PHASE MAIN  
POWER FEEDER 15 AMP

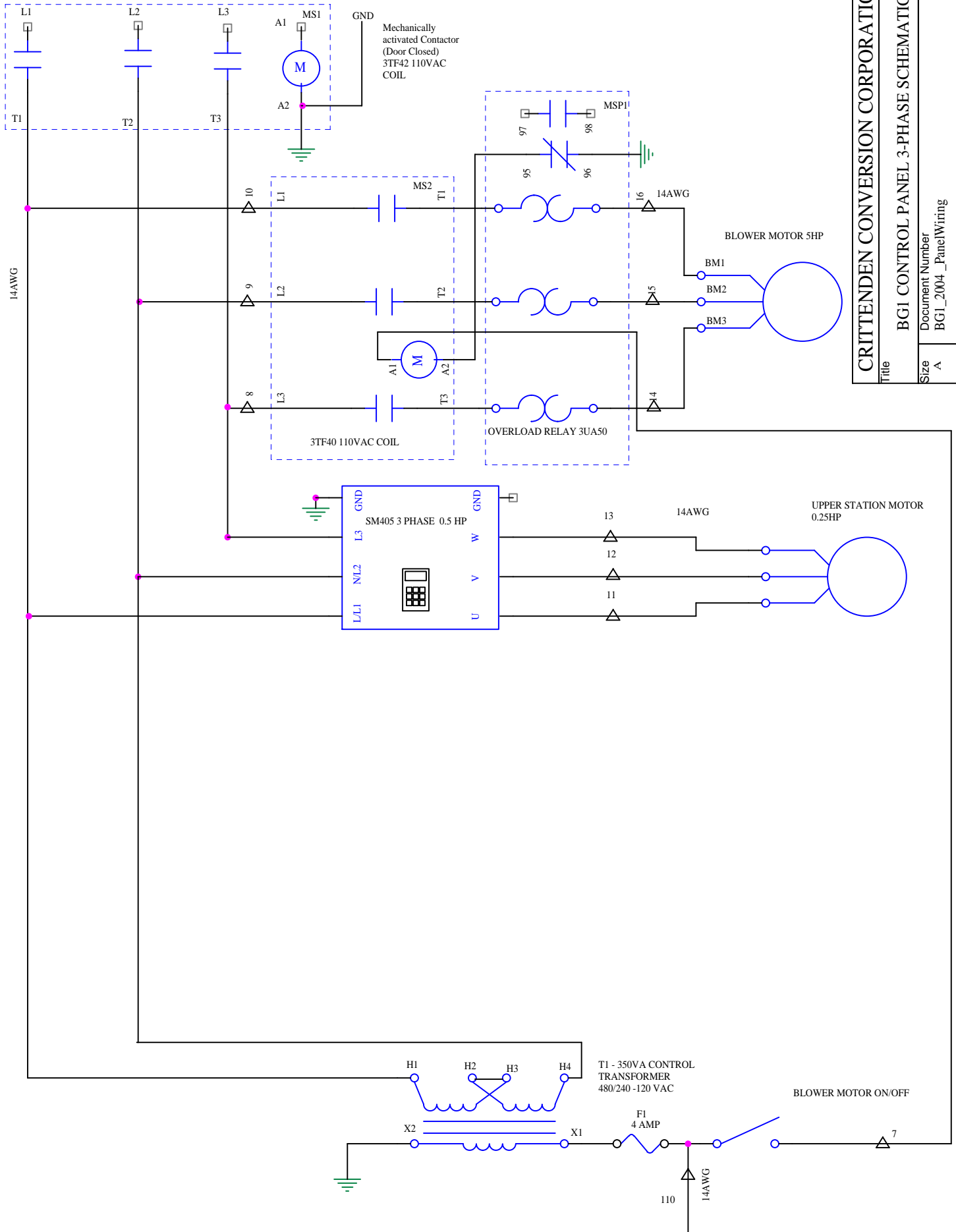

CRITTENDEN CONVERSION CORPORATION

Title		BG1 CONTROL PANEL 3-PHASE SCHEMATIC	
Size	A	Document Number	BG1_2004_PanelWiring
Rev	A	Date:	Tuesday, December 05, 2006
Sheet		1	of 12

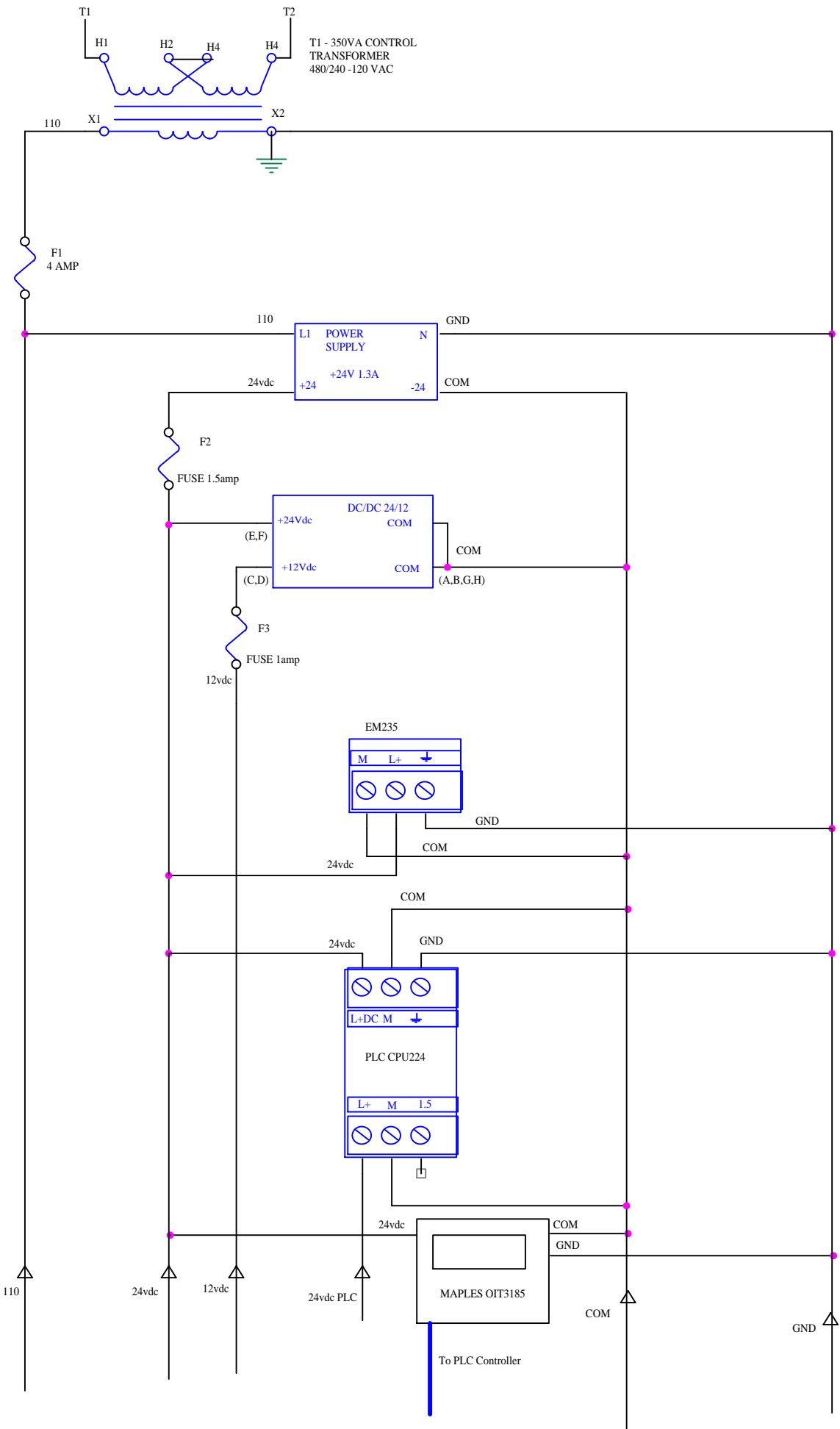

**CRITTENDEN CONVERSION CORPORATION**

Title: BG1 CONTROL PANEL 120VAC TO 24/12 VDC DISTRIBUTION

Size	A	Rev	A
Document Number	BG1_2004_PanelWiring		

Date: Friday, September 17, 2004 Sheet 2 of 12

+12VDC COM

PLC CPU-224 14 INPUTS

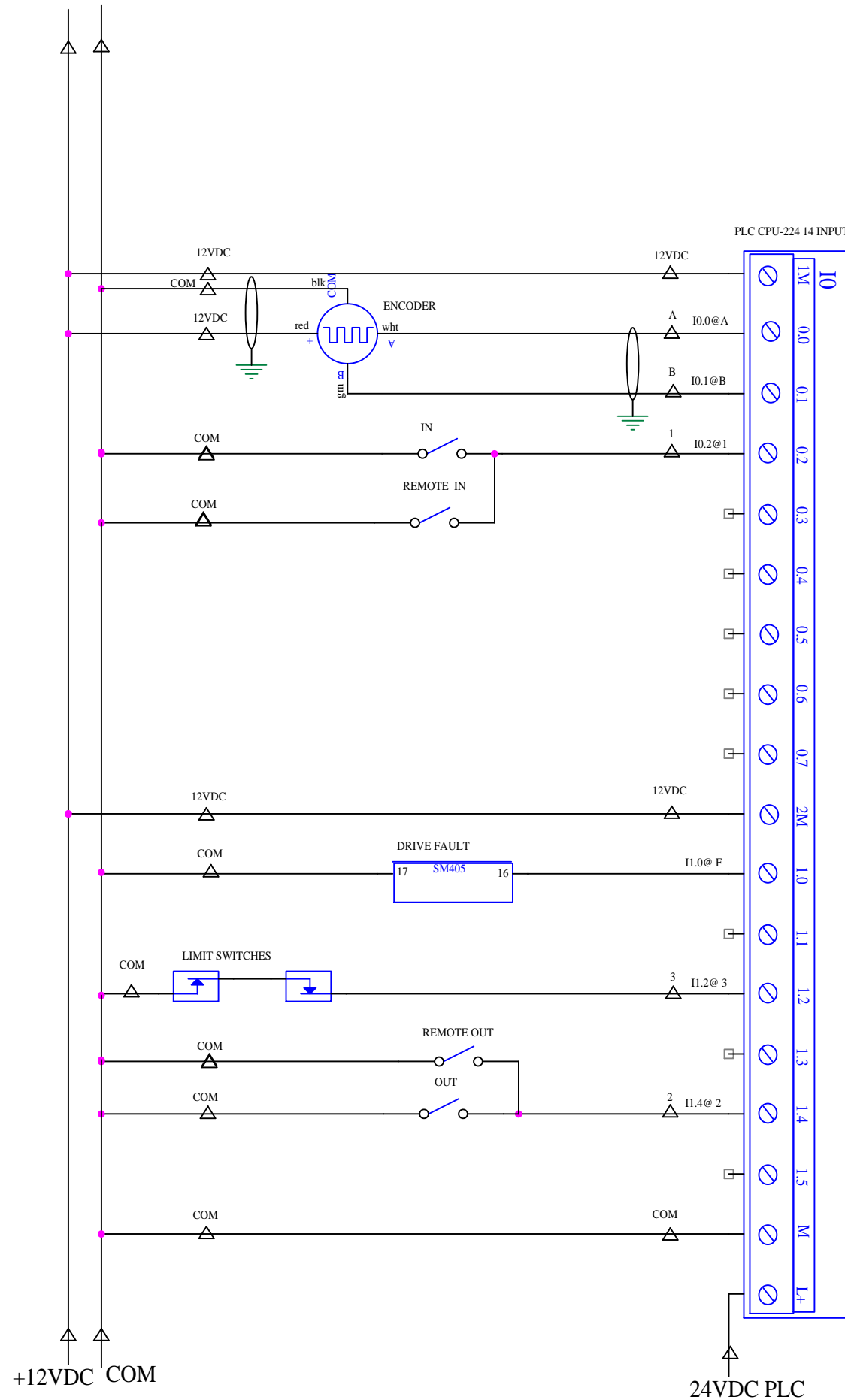

CRITTENDEN CONVERSION CORPORATION

Title BG1 CONTROL PANEL PLC INPUTS MAIN MODULE

Document Number BG1\_2004\_PanelWiring

Rev A

Date: Thursday, December 01, 2005 Sheet 3 of 12

110 VAC 4 AMP

110



110

110

VACUUM ON/OFF

MORE/LESS

6

6

5

5

4

4

Quick Dump

Lower More/Less Motor

3

1

2



GND



GND

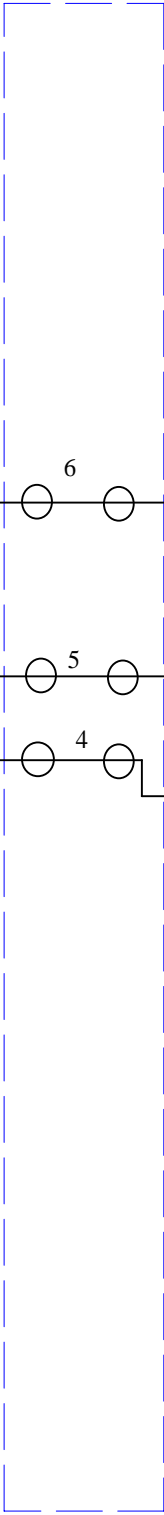

110 VAC 4 AMP

# CRITTENDEN CONVERSION CORPORATION

Title: BGI CONTROL PANEL VACUUM CONTROL SWITCHES SCHEMATIC

Size: A Document Number: BGI\_2004\_PanelWiring Rev: A

Date: Friday, September 17, 2004 Sheet: 4 of 12

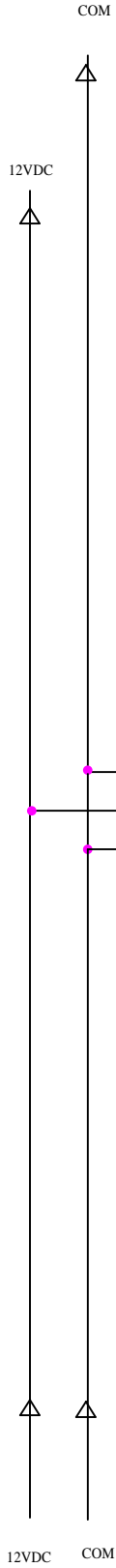

VACUUM SENSOR

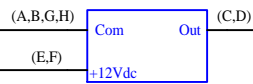

EXTENSION MODULE 4 ANALOG INPUTS EM235

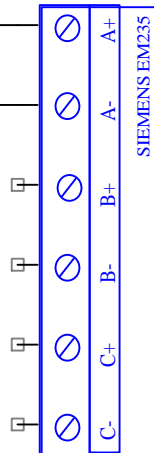

Extension module EM  
235 Configuration  
Switch Settings



**CRITTENDEN CONVERSION CORPORATION**

Title BGI CONTROL PANEL EXTENSION MODULES INPUTS SCHEMATIC

Size A Document Number BGI\_2004\_PanelWiring Rev A

Date: Friday, September 17, 2004 Sheet 5 of 12

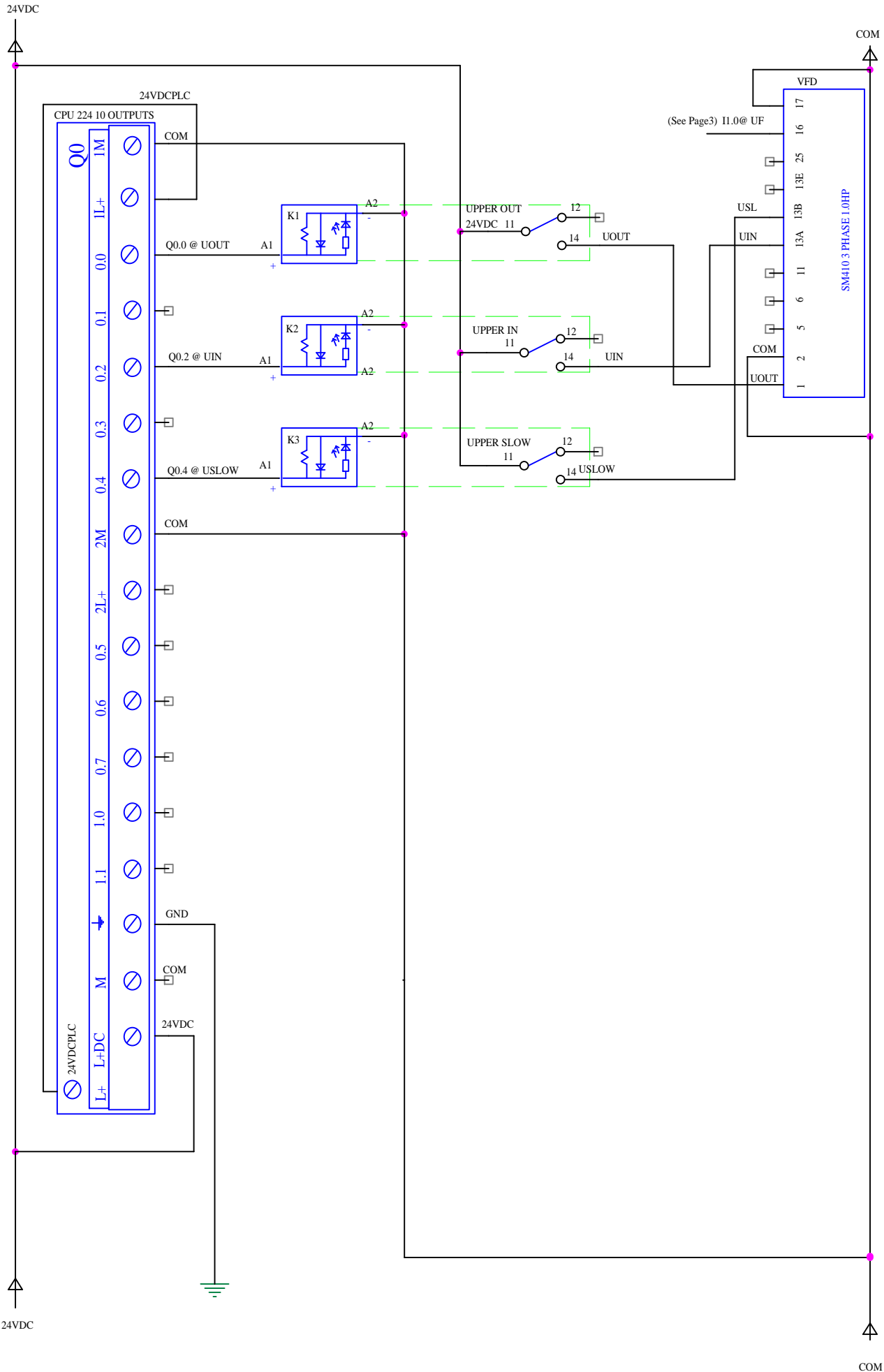

<b>CRITTENDEN CONVERSION CORPORATION</b>	
Title BGI CONTROL PANEL OUTPUTS SCHEMATIC	
Size A	Document Number BGI_2004_PanelWiring
Date: Wednesday, September 13, 2006	Sheet 6 of 12
Rev A	

TERMINAL STRIP IN MAIN CONTROL PANEL 17"

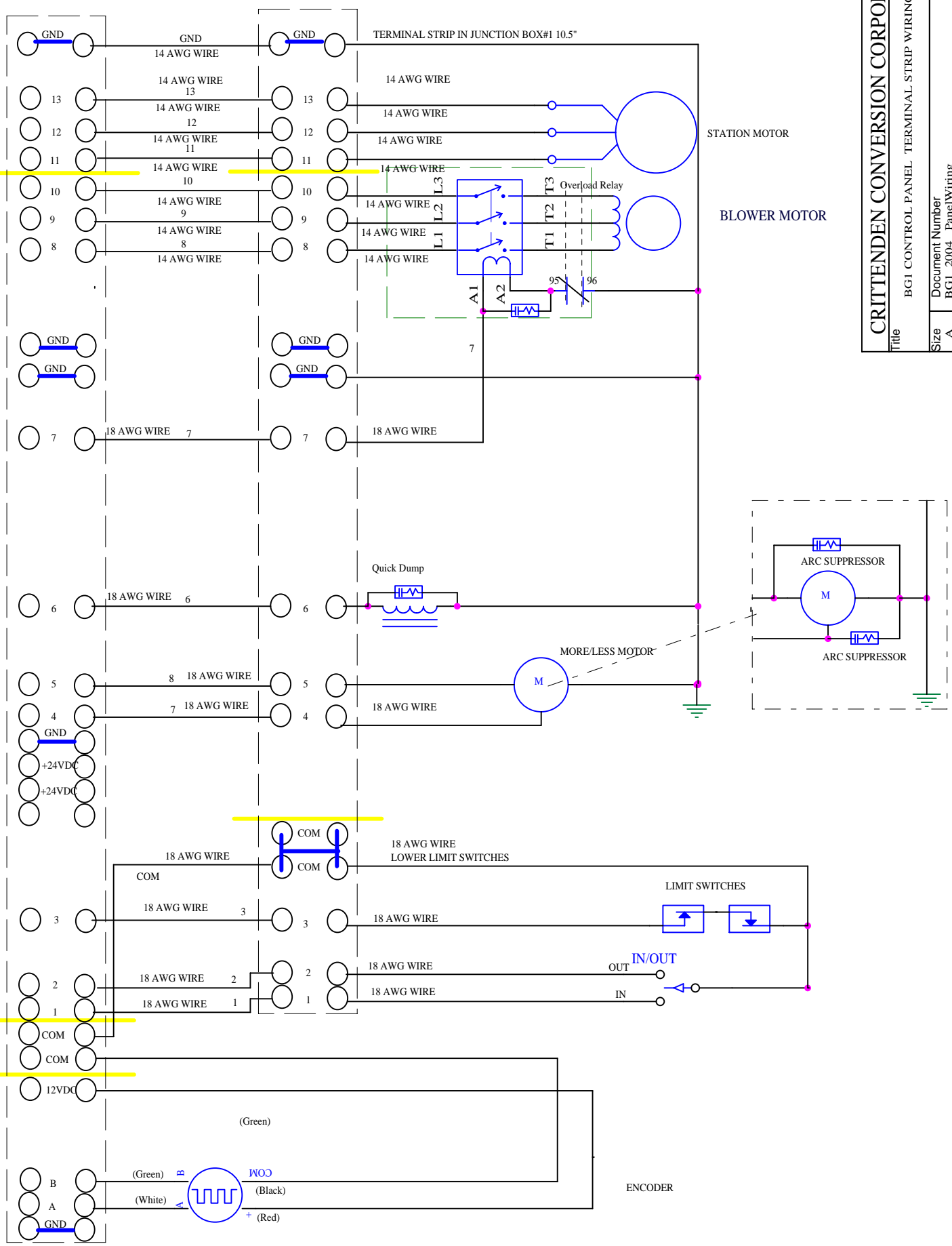

# CRITTENDEN CONVERSION CORPORATION

Title: BG1 CONTROL PANEL TERMINAL STRIP WIRING SCHEMATIC

Rev	A
Document Number	BG1_2004_PanelWiring

Date: Friday, September 17, 2004      Sheet 7 of 12

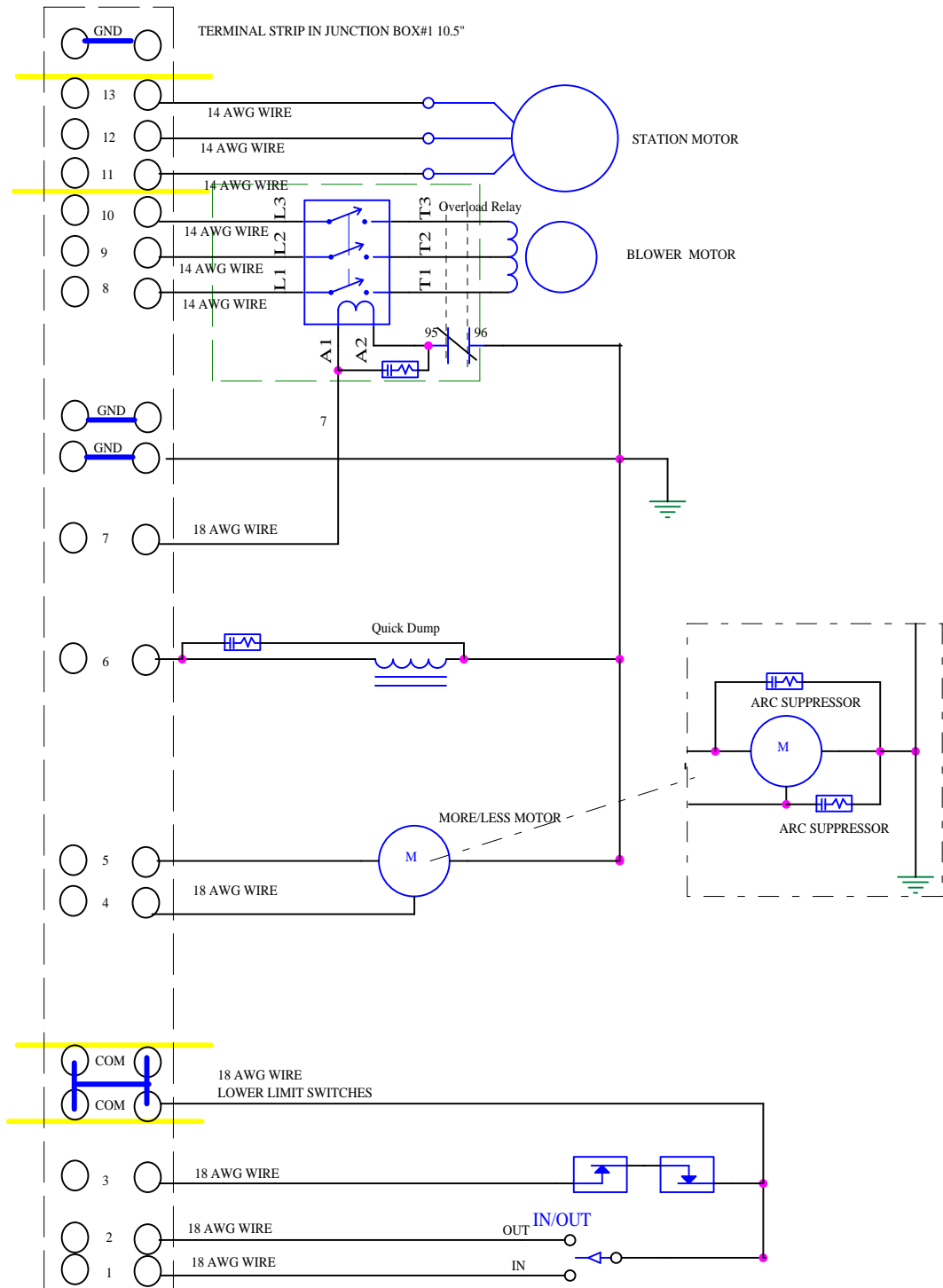

**CRITTENDEN CONVERSION CORPORATION**

Title: BGI CONTROL PANEL BOX#1 TERMINAL STRIP WIRING SCHEMATIC

Size	Document Number	Rev
A	BGI_2004_PanelWiring	A

Date: Friday, September 17, 2004 Sheet 8 of 12



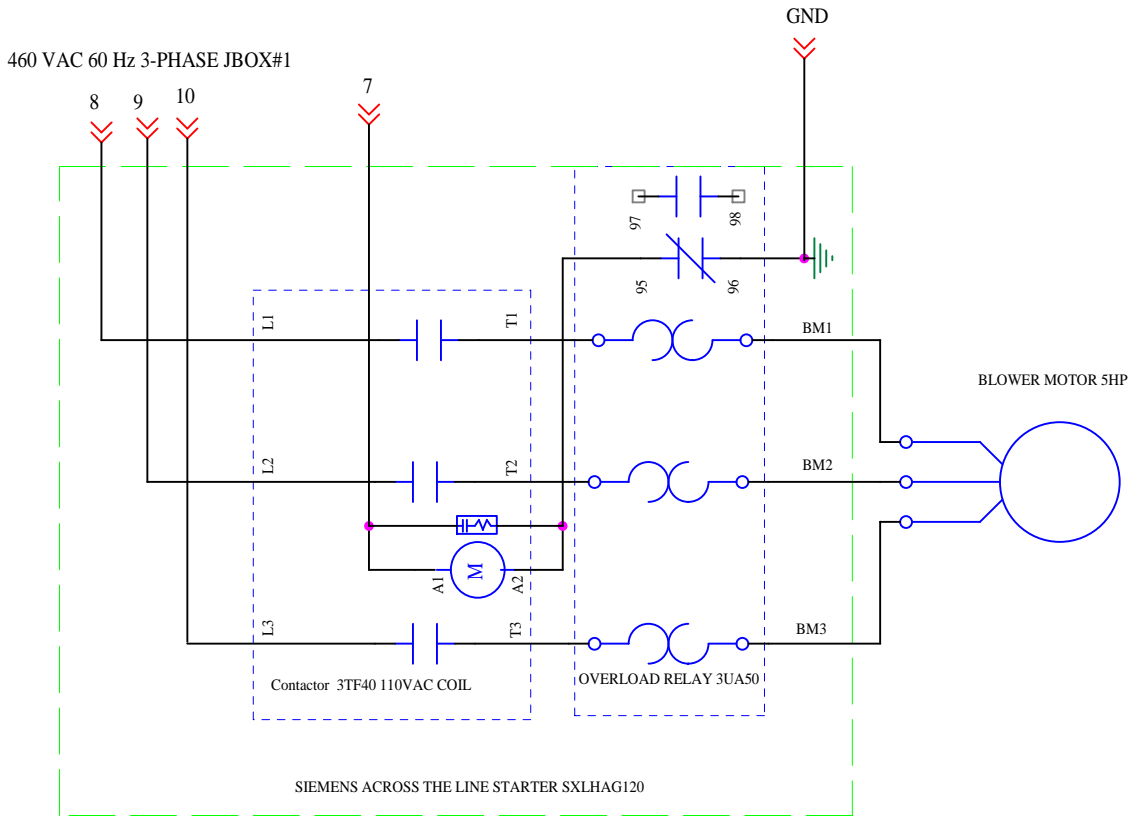

CRITTENDEN CONVERSION CORPORATION

Title

BGI BLOWER 3-PHASE SCHEMATIC

Size

A

Rev

A

Date:

Friday, September 17, 2004

Sheet

9

of

12

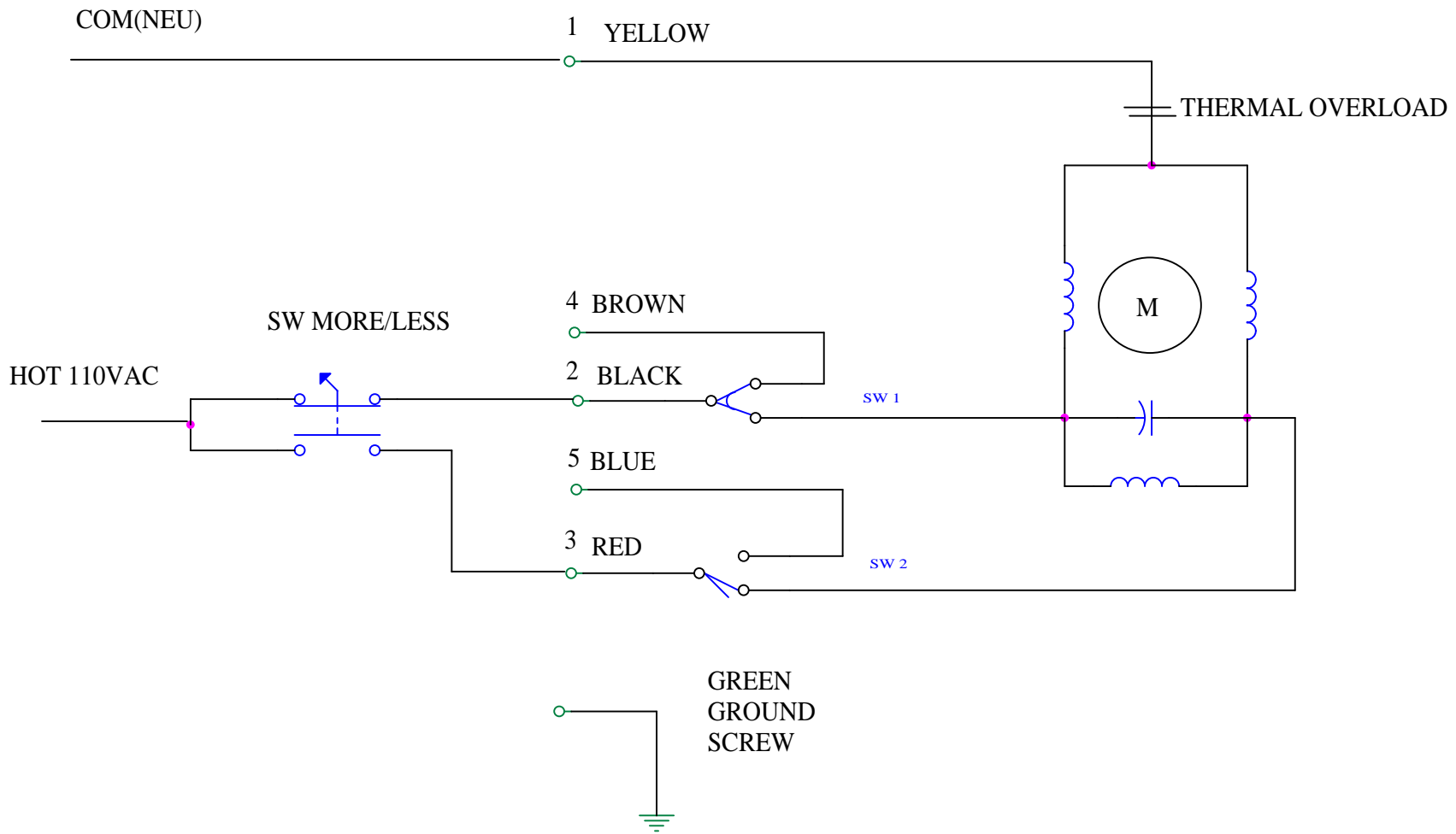

CRITTENDEN CONVERSION CORPORATION		
Title MODEL MAR 8RH-8 120 50/60 0.6 AMP (VACUUM MORE/LESS)		
Size A	Document Number BG1_2004.DSN	Rev A
Date:	Friday, September 17, 2004	Sheet 10 of 12

NO.	PARAMETER NAME	RANGE OF ADJUSTMENT	FACTORY DEFAULT	YOURS
01	LINE VOLTAGE	HIGH (01), LOW (02)	HIGH (01)	-----
02	CARRIER FREQUENCY	4kHz (01), 6 kHz (02), 8 kHz (03), 10 kHz (04)	6 kHz (02)	-----
03	START METHOD	NORMAL (01), START ON POWER UP (02), START WITH DC BRAKE (03), AUTO RESTART WITH DC BRAKE (04), FLYING RESTART 1 (05), FLYING RESTART 2 (06), FLYING RESTART 3 (07)	NORMAL (01)	-----
04	STOP METHOD	COAST (01), COAST WITH DC BRAKE (02), RAMP (03), RAMP WITH DC BRAKE (04)	COAST (01)	<b>RAMP (03)</b>
05	STANDARD SPEED SOURCE	KEYPAD (01), PRESET #1 (02), 0-10 VDC (03), 4-20 mA (04)	KEYPAD (01)	<b>PRESET#1 (02)</b>
06	RELAY OUTPUT	NONE (01), RUN (02), FAULT (03), INVERSE FAULT (04), FAULT LOCKOUT (05), AT SET SPEED (06), ABOVE PRESET #3 (07), CURRENT LIMIT (08), AUTO SPEED (09), REVERSE (10)	NONE (01)	<b>INVERSE FAULT (04)</b>
10	TB-13A FUNCTION SELECT	NONE (01), 0-10 VDC (02), 4-20 mA (03), PRESET SPEED #1 (04), START FORWARD (05), RUN REVERSE (06), START REVERSE (07), EXTERNAL FAULT (08), INVERSE EXT FAULT (09), AUXILIARY STOP (10), ACCEL/DECCEL #2 (11)	NONE (01)	<b>RUN REVERSE (06)</b>
11	TB-13B FUNCTION SELECT	NONE (01), 0-10 VDC (02), 4-20 mA (03), PRESET SPEED #2 (04), DECREASE FREQ (05), START FORWARD (06), JOG FORWARD (07), JOG REVERSE (08), EXTERNAL FAULT (09), INVERSE EXT FAULT (10), AUX. STOP (11), ACCEL/DECCEL #2 (12), REMOTE KEYPAD (13)	NONE (01)	<b>PRESET SPEED 2 (04)</b>

NO.	PARAMETER NAME	RANGE OF ADJUSTMENT	FACTORY DEFAULT	YOURS
12	TB-13E INPUT FUNCTIONS  TB-13E OUTPUT FUNCTIONS  OTHER FUNCTIONS	NONE (01), 0-10 VDC (02), 4-20 mA (03), PRESET SPEED #3 (04), INCREASE FREQ (05), START FORWARD (06), EXTERNAL FAULT (07), INVERSE EXT FAULT (08), AUX. STOP (09), ACCEL/DECEL #2 (10),  RUN (11), FAULT (12), INVERSE FAULT (13), FAULT LOCKOUT (14), AT SET SPEED (15), ABOVE PRESET #3 (16), CURRENT LIMIT (17), AUTO SPEED (18), REVERSE (19), DYNAMIC BRAKING (20),  REMOTE KEYPAD (21)	NONE (01)	-----
14	CONTROL	TERMINAL STRIP ONLY (01) REMOTE KEYPAD ONLY (02)	TERMINAL STRIP ONLY (01)	-----
16	UNITS EDITING	TENTHS OF UNITS (01), WHOLE UNITS (02)	WHOLE UNITS (02)	-----
17	ROTATION	FORWARD ONLY (01), FORWARD AND REVERSE (02)	FORWARD ONLY (01)	FORWARD AND REVERSE (02)
19	ACCELERATION TIME	0.1 - 3600.0 SEC	20.0 SEC	1
20	DECELERATION TIME	0.1 - 3600.0 SEC	20.0 SEC	0.1
21	DC BRAKE TIME	0.0 - 3600.0 SEC	0.0 SEC	-----
22	DC BRAKE VOLTAGE	0.0 - 90.0 %	0.0 %	-----
23	MINIMUM FREQUENCY	0.0 - MAXIMUM FREQUENCY	0.0 Hz	-----
24	MAXIMUM FREQUENCY	MINIMUM FREQUENCY - 240 Hz	SCL = 500 Hz SCM = 60.0 Hz	80
25	CURRENT LIMIT	90 - 180 %	180 %	-----
26	MOTOR OVERLOAD	90 - 100 %	100 %	82
27	BASE FREQUENCY	25.0 - 500.0 Hz	SCL = 500 Hz SCM = 60.0 Hz	-----
28	FIXED BOOST	0.0 - 90.0 %	1.0 %	5.3
29	ACCEL BOOST	0.0 - 20.0 %	0.0 %	-----

NO.	PARAMETER NAME	RANGE OF ADJUSTMENT	FACTORY DE FAULT	YOURS
30	SUP COMPENSATION	0.0 - 5.0 %	0.00%	-----
31-37	PRESET SPEEDS	0.0 - MAXIMUM FREQUENCY	0.0 Hz	<b>31 – 80; 32- 4</b>
38	SKIP BANDWIDTH	0.0 - 10.0 Hz	0.0 Hz	-----
39	SPEED SCALING	0.0 - 6500.0	0.0	-----
42	ACCEL/ DECEL #2	0.1 - 36000.0 SEC	20.0 SEC	<b>0.1</b>
44	PASSWORD	000 - 999	225	-----
45	SPD AT MIN SIGNAL	MINIMUM FREQUENCY - 999 Hz	0.0 Hz	-----
46	SPD AT MAX SIGNAL	MINIMUM FREQUENCY - 999 Hz	SCL = 50.0 Hz SCM = 60.0 Hz	-----
47	CLEAR HISTORY	MAINTAIN (01), CLEAR (02)	MAINTAIN (01)	-----
48	PROGRAM SELECTION	USER SETTINGS (01), OEM SETTINGS (02), RESET OEM (03), RESET 60 (04), RESET 50 (05), TRANSLATE (06)	SCL = RESET 50 (05) SCM = RESET 60 (04)	-----
50	FAULT HISTORY	(VIEW-ONLY)	(NA)	-----
51	SOFTWARE CODE	(VIEW-ONLY)	(NA)	
52	DC BUS VOLTAGE	(VIEW-ONLY)	(NA)	
53	MOTOR VOLTAGE	(VIEW-ONLY)	(NA)	
54	LOAD	(VIEW-ONLY)	(NA)	
55	0-10VDC INPUT	(VIEW-ONLY)	(NA)	
56	4-20 mA INPUT	(VIEW-ONLY)	(NA)	
57	TB STRIP STATUS	(VIEW-ONLY)	(NA)	
58	KEYPAD STATUS	(VIEW-ONLY)	(NA)	