

LATCH ADJUSTMENT

EXAGGERATED VIEW

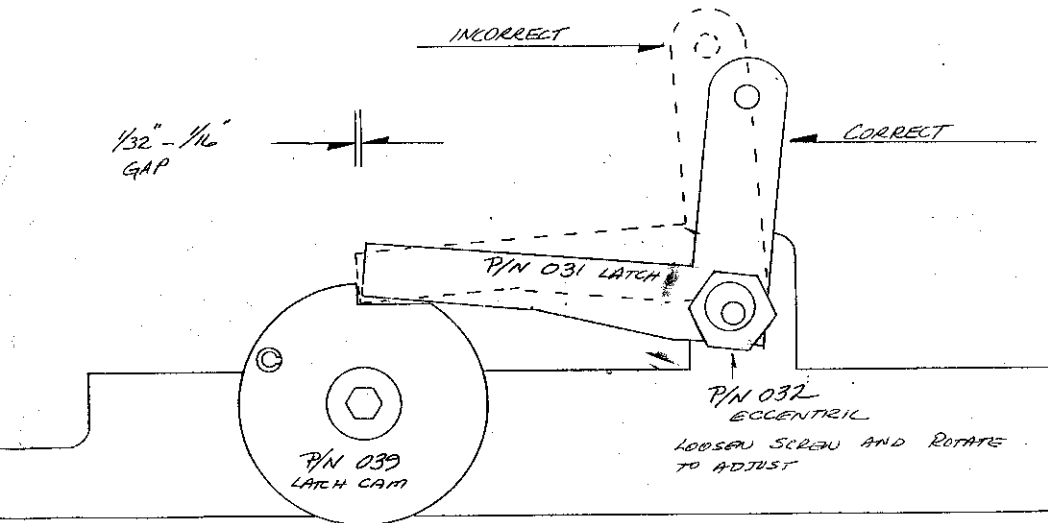

AFTER ABOVE ADJUSTMENT HAS BEEN MADE, YOU WILL NEED TO RE-ADJUST THE #6 RESTRICTOR VALVE IN THE AIR LINE GOING TO THE #28 LATCH CYLINDER. GATE SHOULD REMAIN LATCHED JUST LONG ENOUGH FOR THE 1ST STITCH TO BE DRIVEN INTO BOX!