



CRITTENDEN CONVERSION CORPORATION
MOSES LAKE, WASHINGTON

VACUUM BRIDGE GUIDE 2003



Table of Contents

SYSTEM OVERVIEW	6
BEFORE START	9
SYSTEM SETUP	10
VACUUM ADJUSTMENT PROCEDURE	11
BG 2003 OPERATION	13
TROUBLESHOOTING	22
BG3 PLC DIGITAL INPUTS	24
BG3 PLC ANALOG INPUTS	25
BG3 PLC DIGITAL OUTPUTS	25
BG3 ANALOG OUTPUTS	26
POWER BUDGET	27
KEYS	28
SCREENS	31
Screen #1	31
Screen #2	32
Screen #3	33
Screen #4	35
Screen #5	37
Screen #6	38
Screen #7	39
Screen #8	40
Screen # 9	42
Screen #10	44
Screen #11	45

Screen #12	46
Screen #13	48
Screen #14	49
Screen #15	50
Screen #16	52
Screen #17	53
Screen #18	54
Screen #19	55
Screen #20	56
Screen #21	58
Screen #22	59
Screen #23	61
Screen #24	63
Screen #25	65
Screen #26	66
Screen # 27	67
Screen #28	68
Screen #29	69
Screen #30	70
Screen #31	71
Screen #32	73
Screen #33	74
Screen #34	76
Screen #35	78
Screen #36	79
Screen #37	80
Screen #38	81
Screen #39	83

Screen #40	85
Screen #41	87
Screen #42	88
Screen #43	90
Screen #44	91
Screen #45	92
Screen #46	93
Screen #47	94
Screen #48	95
Screen #50	96
Screen #51	97
Screen #52	98
Screen #53	100
Screen #54	101
Screen #55	104
Screen #56	106
Screen #57	107
HELP SCREENS	109
Screen #400	109
Screen#403	109
Screen #404	109
Screen #405	109
Screen #406	110
Screen #407	110
Screen #408	110
Screen #410	110
Screen #411	110
Screen #413	111

Screen #414	111
Screen #415	111
Screen #417	111
Screen #419	112
Screen #420	112
Screen #425	112
Screen #426	112
Screen #427	112
Screen #428	113
Screen #431	113
Screen #433	113
APPENDIX.....	114
SCHEMATIC DIAGRAMS	
1 BG3 CONTROL PANEL 3-PHASE SCHEMATIC	
2 BG3 CONTROL PANEL 120VAC TO 24/12 VDC DISTRIBUTION	
3 BG3 CONTROL PANEL PLC INPUTS MAIN MODULE	
4 BG3 CONTROL PANEL VACUUM CONTROL SWITCHES SCHEMATIC	
5 BG3 CONTROL PANEL EXTENSION MODULES INPUTS SCHEMATIC	
Extension module EM 235-OKD22-0XA0 AI4/AO Configuration Switch Settings	
6 BG3 CONTROL PANEL OUTPUTS SCHEMATIC	
7 BG3 CONTROL PANEL TERMINAL STRIP WIRING SCHEMATIC	
8 BG3 CONTROL PANEL BOX#1 TERMINAL STRIP WIRING SCHEMATIC	
9 BG3 BLOWER 3-PHASE SCHEMATIC	
10 MODEL MAR 8RH-8 120 50/60 0.6 AMP (VACUUM MORE/LESS)	
11 BG-2003 - Vacuum Unit	
12 DC-DC CONVERTER 24VDC/12VDC-VR-2002/12/10	
ASSEMBLING DIAGRAMS	
1 CONDUITS AND JUNCTION BOXES	
2 CABLES	
3 JUNCTION BOX #1	
4 MANUAL MOVE REMOTE CONTROL BOX	
5 JUNCTION BOX#3#13	
6 JUNCTION BOX#7	
7 JUNCTION BOX#9	
8 JUNCTION BOX#10	
9 JUNCTION BOX#12	
10 BG3 CONTROL PANEL FRONT INSIDE WIRING	
VARIABLE FREQUENCY DRIVE SM405 PARAMETER TABLE	
OIT TROUBLESHOOTING	

System Overview

The bridge guide 2003 control system has been designed to provide automatic and manual opening width changing control for upper, middle and lower bridge guide stations.

Guides are moved with three 1/4 HP motors. Variable Frequency Drives (VFD) are used to drive the motors with two different speeds low and high. Positioning feedback information comes from the hollow shaft quadrature encoders, which send impulse sequences to the Programming Logic Controller (PLC). The PLC is used for processing these sequences and providing control signals to move and stop guides at desired positions.

The blower unit with a 5 HP motor is used as a vacuum source for all vacuum chambers. Three MORE-LESS vacuum motors control the level of vacuum in the vacuum chambers. Three solenoids allow vacuum quick dump.

Operators can read and change vacuum and current position values for all stations from the Operator Interface Terminal (OIT) screen, guides may be moved using manual switches on the Main and Remote panel.

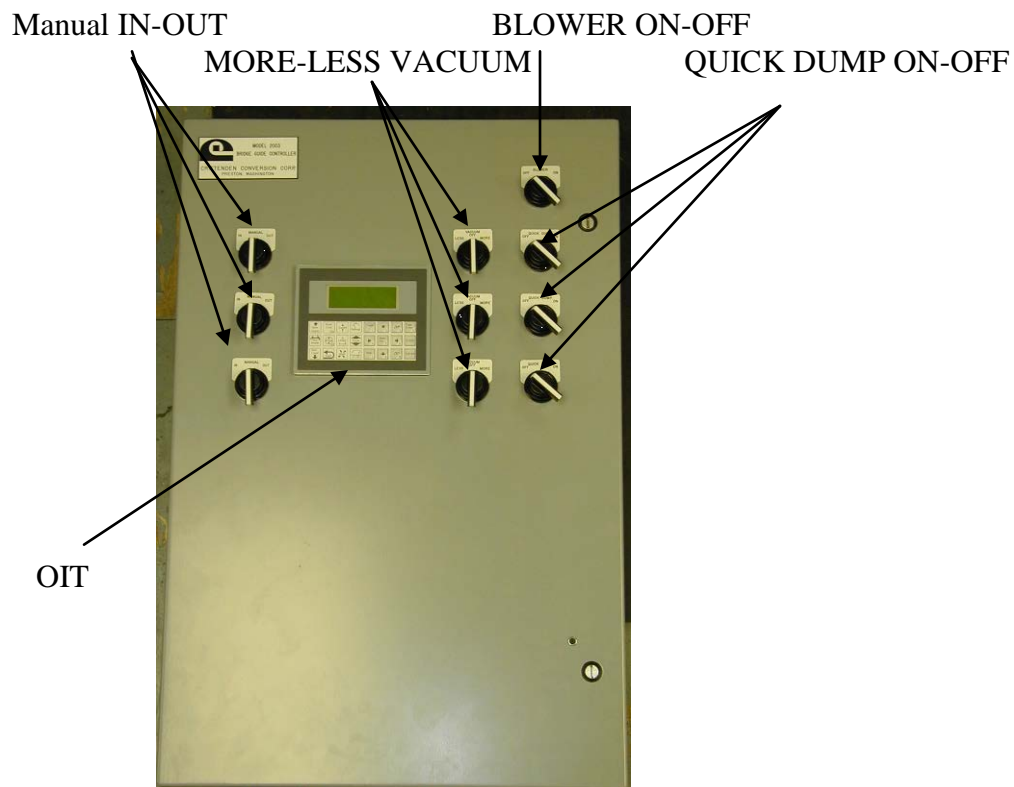

Figure 1. Main Panel front view

Two additional “Manual IN-OUT” switches locate on the opposite BLOWER side of the bridge to provide manual positioning control for the operator.

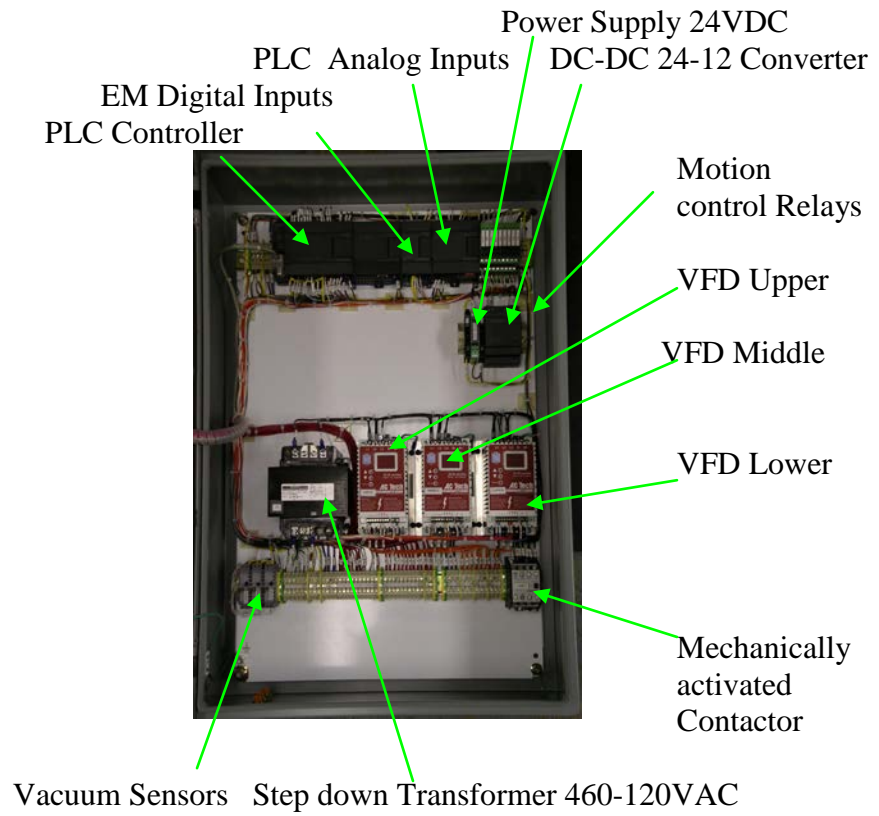

Figure 2. Main Panel inside view.

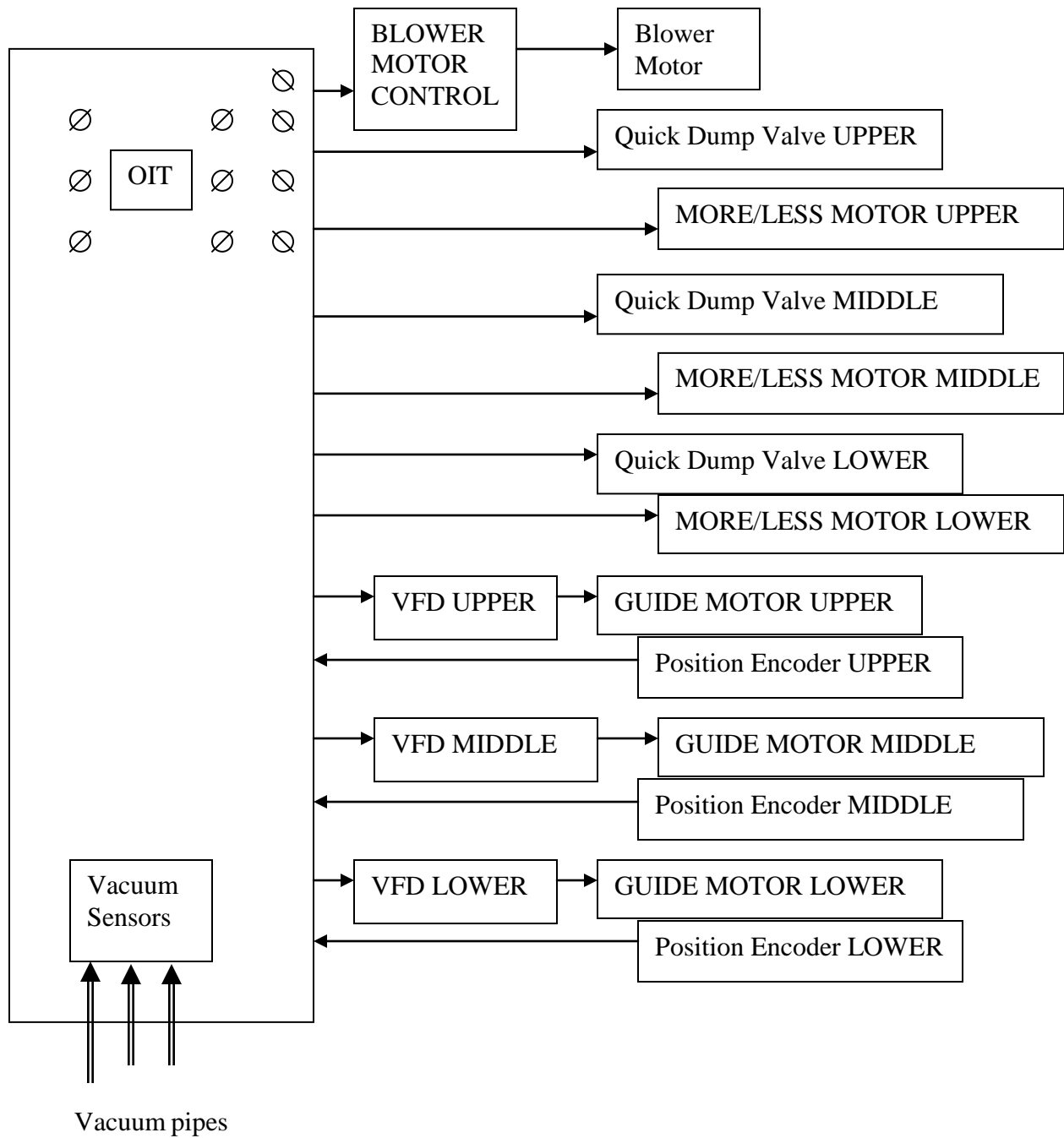

Figure 3. Diagram of System Configuration

Before Start



1. Connect 3 phase 480VAC from the 15 AMP source to the inputs (L1, L2, L3) mechanically activated contactor in the Main panel. Run all high voltage wires separate from the low voltage and control wires.
2. Close the panel and make sure door is closed tightly.
3. After the introduction logo message appears on the Operator Interface Terminal (OIT) screen, turn “Blower ON/OFF” switch ON.
4. Check rotational direction of Blower. Swap the input two power wires if wrong.
5. Use “Manual IN/OUT” switches for all stations to move guides from the limit switches into the working area (Trip Arm is located between two limits). Check for the correct motion direction. Swap wires on the motors if wrong.
6. Guides must stop when they reach limit switches. Check limit switches (Normally Closed) and wiring if guides do not stop.

SYSTEM SETUP

1. Make sure that Guides are locating in the working area (Trip Arm is located between limit switches). If not move them manually or use “Manual IN/OUT” switches.

Attention!!! Do not try “Move home” until you make sure that the Guides are located between limit switches and Limit switches properly wired and tested.

2. Push “Home” key. 

- On the message “Home? “ Select “Yes” 
- To Stop Guide movement push “Stop” key  or 
- On message “Maximum width” enter measured width values for all stations (values can be **Metric** or **English**)

- Push Enter 

- Push Yes 
- On message “Minimum width” enter measured width values for all stations (values can be **Metric** or **English**).

- Push Enter 

- Push Yes 

3. System is ready. Numbers are now saved into the memory. Switching power OFF/ON does not change them. (It is possible to lose that setting if system remains OFF for more than 6 months.)

Vacuum adjustment procedure

- 1) Push button 

On the screen you will see

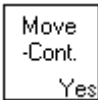

- 2) Push  - Yes



- 3) Enter password 0000



Turn off Blower.

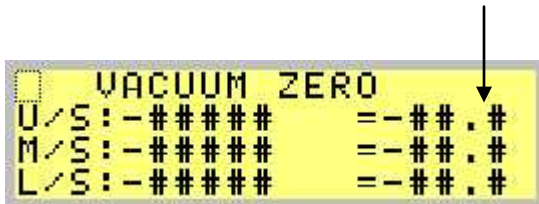

On the screen you will see

Current Vacuum Readings for Upper/Middle/Lower



- 4) Use  and  to chose Upper, Middle or Lower station

- 5) Use  and  to Increase or Decrease Zero adjustment numbers

Or Push  and enter numbers, and then Push 

- 6) Change numbers until Current readings equal zero

7) Push



Turn ON Blower and put paper on the vacuum chambers. Use vacuum meter gage to compare with readings.

On the screen you will see



- 9) Adjust slope similar with procedure described above. Use “More-Less” vacuum adjustments to set values in maximum (~15-20) and medium (~7-10).
- 10) Return to the previous screen and repeat ZERO adjustment if it’s necessary.

BG 2003 Operation

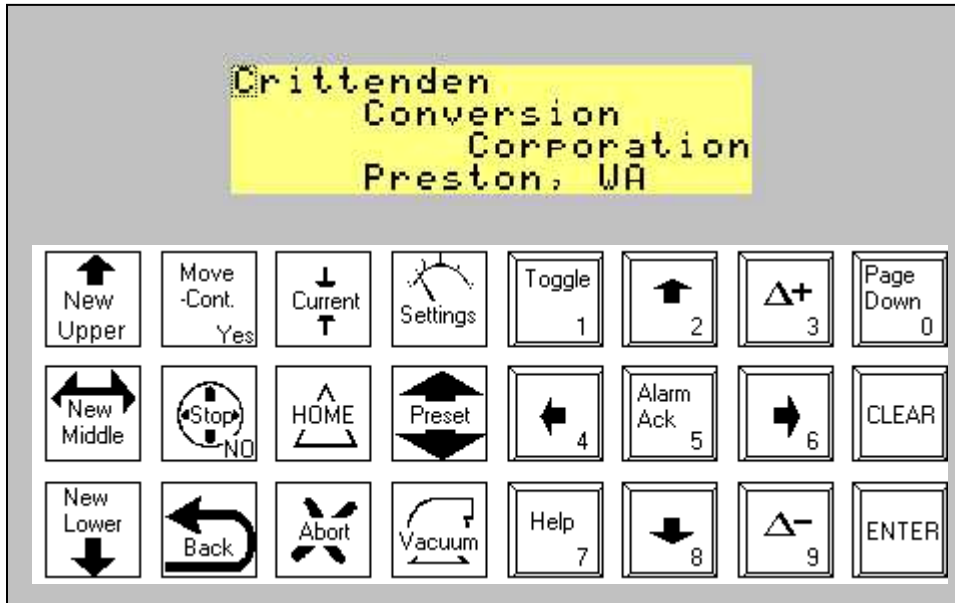

2. Get Help



- Push and hold "Help  " key
- Read Help screen

3. See current Width.

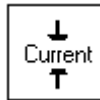

- Push "Current" key

4. See current Vacuum readings.

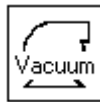

- Push "Vacuum" key.

5. Enter New Upper station width (values can be Metric or English).



- Push "New Upper" key;



- Push "Clear",

- Enter numbers (for example: 44.5 > 4, 4, 5)



- Push "Enter"

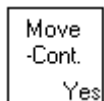

- Push "Yes"

6. Enter New Lower station width (values can be Metric or English).

- Push "New Lower" key;

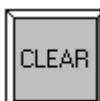

- Push "Clear",

- Enter numbers (for example: 44.5 > 4, 4, 5)



- Push "Enter"

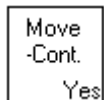

- Push "Yes"

7. Enter New Middle station width (values can be Metric or English).

- Push "New Middle" key;



- Push "Clear",

- Enter numbers (for example: 44.5 > 4, 4, 5)



- Push "Enter"

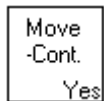

- Push "Yes"

8. Move to the new width.

- Push "Move"

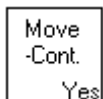

- Check numbers on the screen “from 44.5 to 75.2”



- Push “Move”

9. Stop when moving.



- Push “Stop”

- On the message “Continue or Back” select “Move” or “Back”

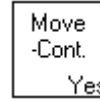

10. Move Home.



- Push “Home” key.

- On the message “Home? “ Select “Yes” or “NO”

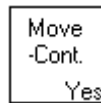

- You can stop any time to push “Stop” key.



- On message “Maximum width” enter measured width values for all stations



- Push Enter

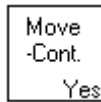

- Push Yes

- On message “Minimum width” enter measured width values for all



stations. Push Enter



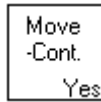

- Push Yes











11. Abort motion and operation – Reset controller.

- Push "Abort"  or Turn power Off
- On message "Abort everything?" select "Yes". 

12. Change settings. (Vacuum scale and slope, distance before speed slow down, demo mode)

- Push "Settings" key 
- On the message "Are you sure to change settings?" select "Yes", 
- Enter password 0000,
- Change settings

13. Change Preset.

- Push "Preset" key. 
- Push "clear", 
- Enter new preset value.
- Push Enter 
- Push "Page Down" 
- On the message "Assign to new Upper Width?" Select "Yes"  or
 "No" 
- On message "Assign to new Lower Width?" select "Yes"  or "No"

- "Swap Upper new and Lower new"

-” Assign to Upper new to lower new?”
-” Assign to Lower new to Upper new?”
-” Assign to Upper new to Middle new?”
-” Assign to Preset to Middle new?”

14. Stop Alarm

- Push “Alarm Acknowledgment”



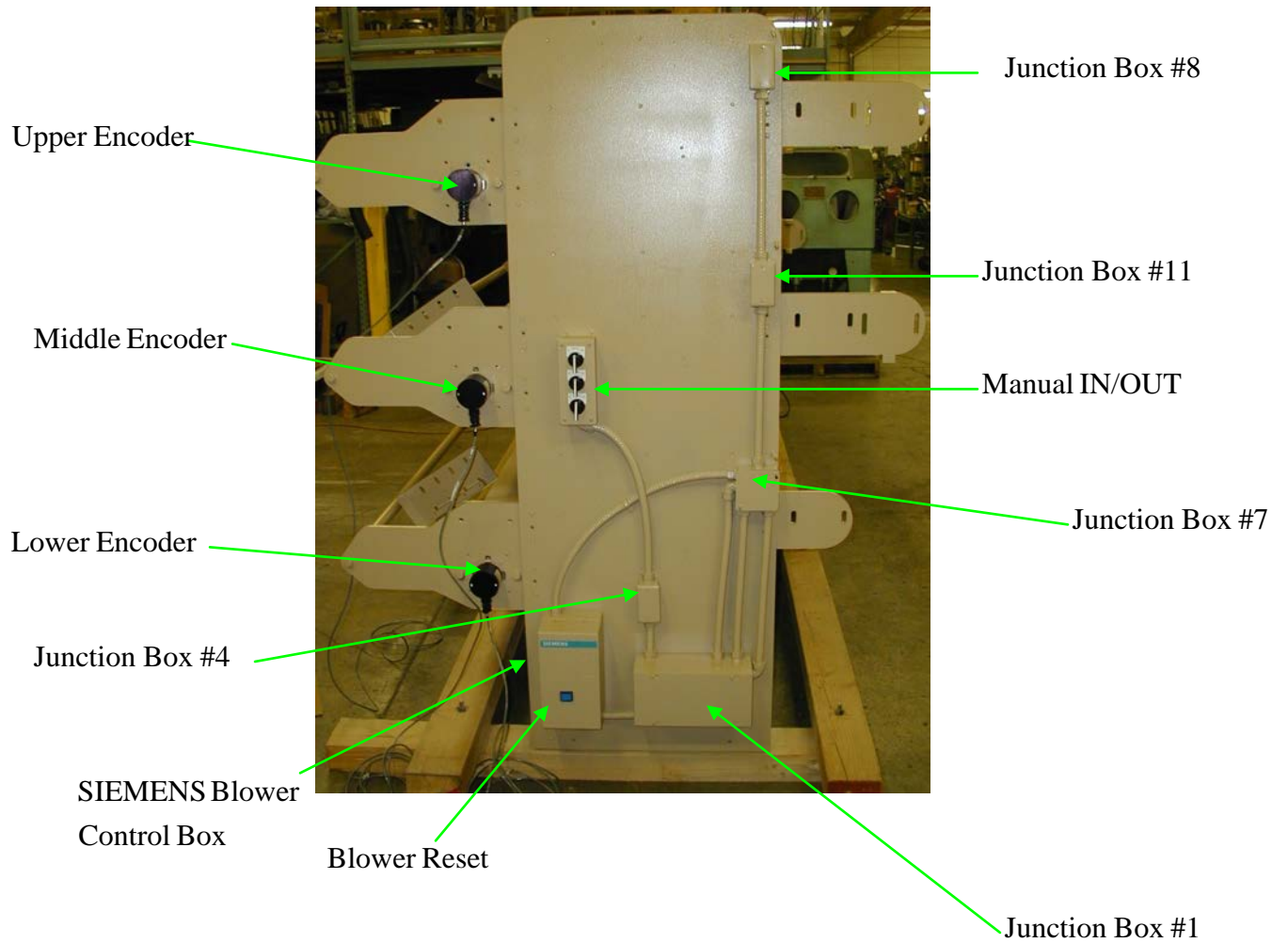

Figure 4. Manual switches side.

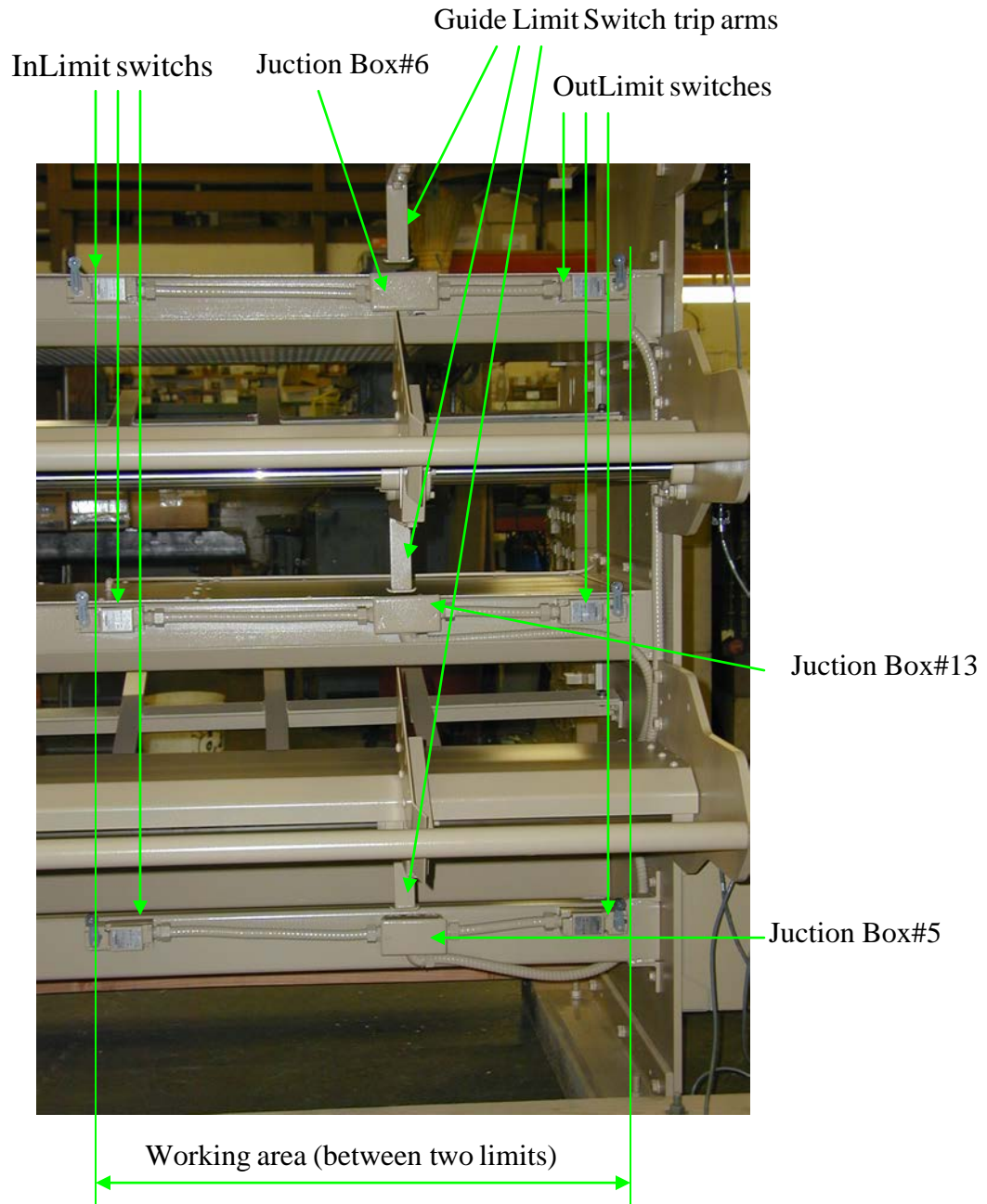

Figure 5. Limit Switches

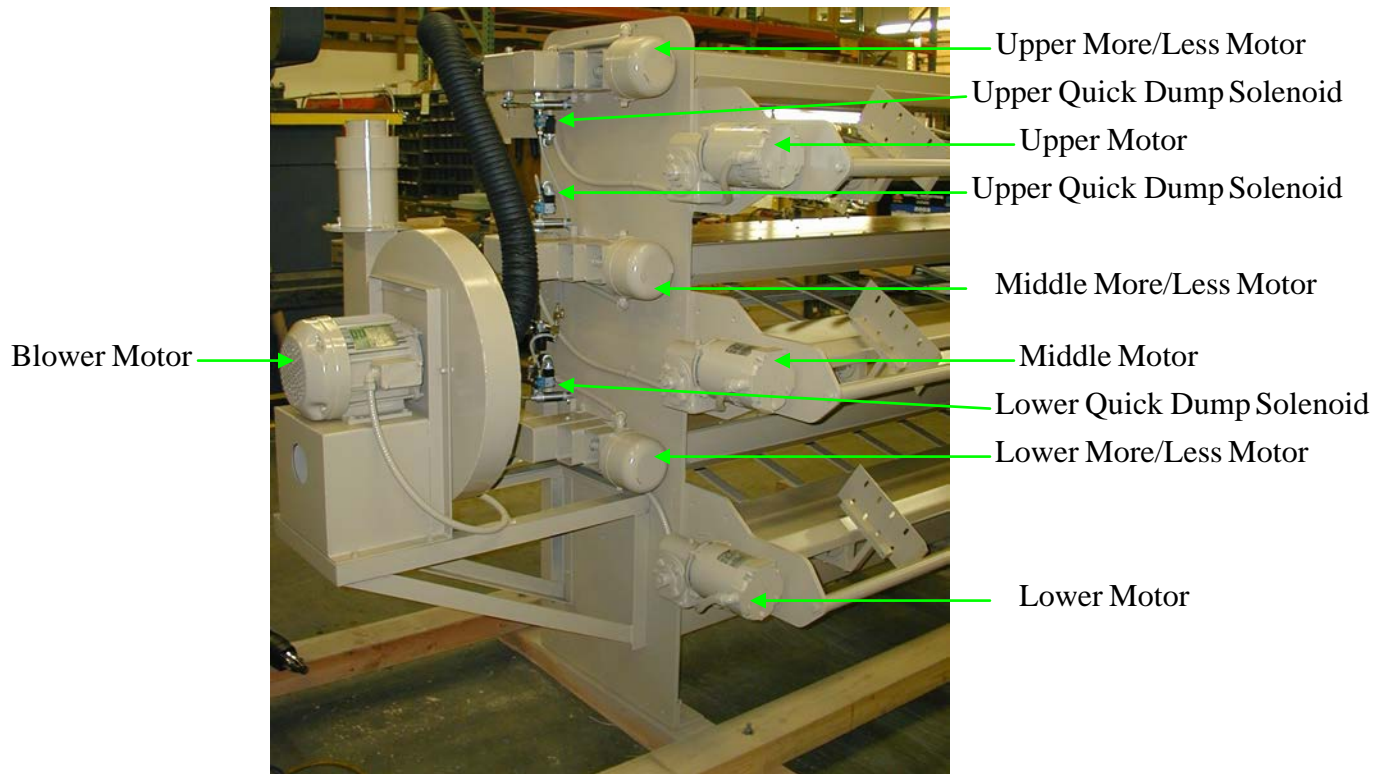

Figure 6. Blower side

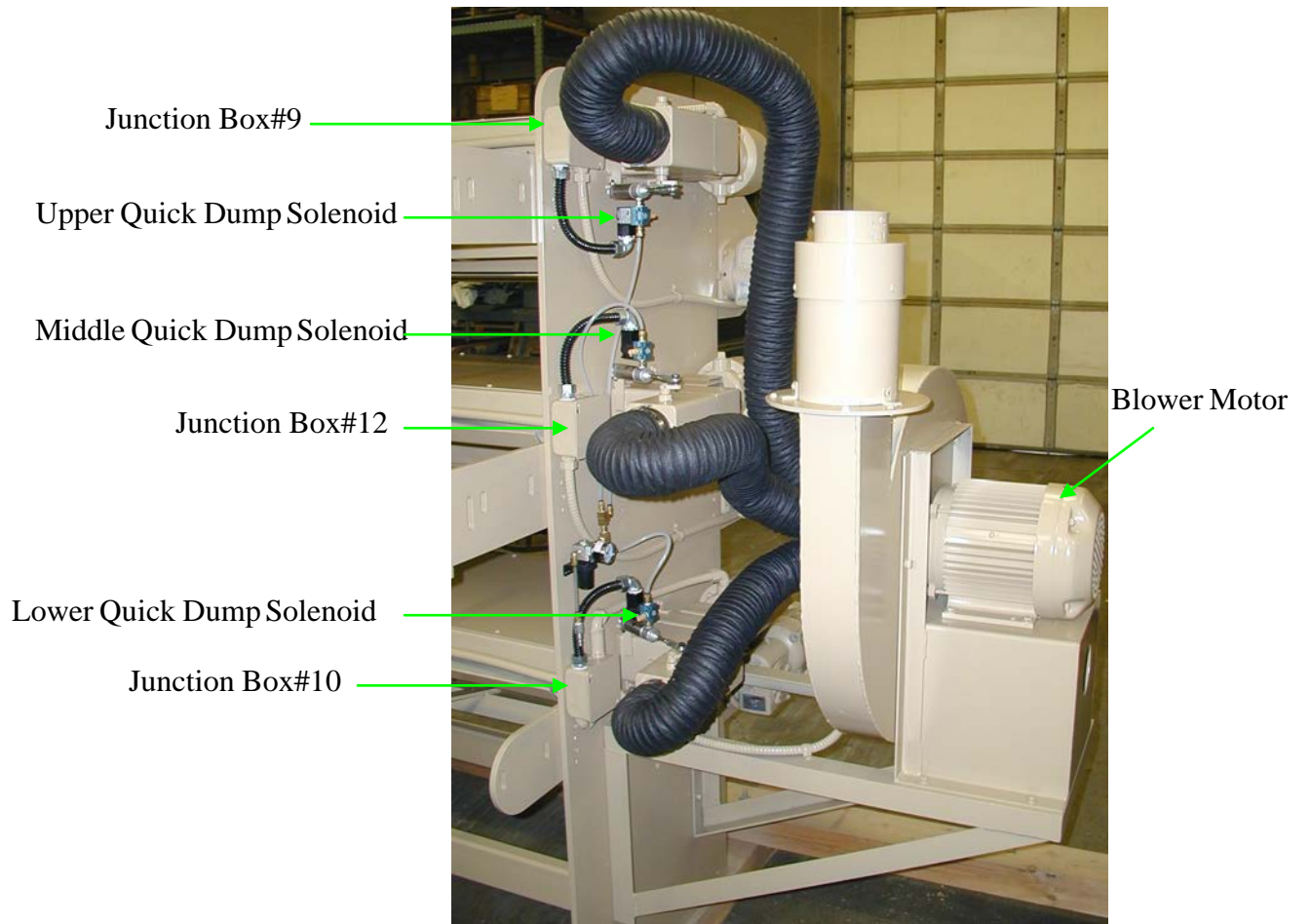

Figure 7. Blower

Troubleshooting

ACTION	SCREEN/SYSTEM	POSSIBLE SOURCE OF PROBLEM	SOLUTION
System power on	The OIT screen is dark and -Manual IN and OUT does not work	No power 440VAC or 110 VAC No power 24 VDC.	Check the main panel door Is it completely closed? Check 440/110 Vac. Check the fuses in the main panel. Check 24 Vdc from the power supplies in the main panel.
System power on	The OIT screen is dark and -Manual IN and OUT does work	No power to OIT.	Check wires from terminal to the OIT in the main panel.
System power on	Error message on the OIT screen	Read message and follow recommendation on the screen and HELP screen.	Read message and follow recommendation on the screen
No motion	No messages	- Corresponding Control relays failed - VFD failed	Open main panel Power up manually and check error code from the VFD display. Check corresponding relays cause of the problem.
Checking vacuum	Readings “00” does not changing when using More or Less switch Blower working properly.	There is no paper. Vacuum pipe is not on vacuum sensor or bad sensor.	Check fuse or 12 DC on the sensor’s terminals. .Install pipe or replace pipe or sensor
Start Blower	Blower starts but no vacuum	- No paper - Wrong rotational direction	- Put paper - Swap 2 input power wires
Start Blower	Blower does not start.	Overload protection relay turned off. No 460 VAC 3Phase power.	Push reset on the Blower control panel. Check 460 VAC 3 Phase power source.

Start More-Less	More-Less does not work	No power 110 VAC from the main panel or switch or “more less” motor does not work	Check power 110 VAC from main panel to the More-less switch and to the More-less motor
Start motion	Guides move into wrong direction	Wrong 3 phase power phasing	Swap two input 3 phase power wires on the corresponding motor.
Start motion	Numbers move in wrong direction	Wrong encoder phasing	Swap A and B channel encoder wires.
Start motion	Screen show motion screen but no any motion	- Check next width numbers for out limit values. - Check VFDs for possible errors	- Reenter correct next width -Open main panel. Power up and check for error messages on VFDs.

BG3 PLC DIGITAL INPUTS

	INPUTS	Device	Wires #	PLC ADDRESS
1	Upper station Positioning Encoder	Upper Encoder Ch A	A	I0.0
2	Pulses	Ch B	B	I0.1
3	Upper station Manual IN	Switch Upper Manual In/Out	1	I0.2
4	Lower station Positioning Encoder	Lower Encoder Ch A	E	I0.3
5	Pulses	Ch B	F	I0.4
6	Upper station Manual OUT	Switch Upper Manual In/Out	2	I1.4
7	Lower station Manual IN	Switch Lower Manual In/Out	5	I1.3
8	Lower station Manual OUT	Switch Lower Manual In/Out	6	I1.5
9	Upper station LIMIT switch	Upper Limit switches	7	I1.2
10	Lower station LIMIT switch	Lower Limit switches	9	I0.5
11	Upper Drive Fault	VFD Upper	UF	I1.0
12	Lower Drive Fault	VFD Lower	LF	I1.1
13	N/U		N/U	
14	N/U		N/U	
1	Middle station Positioning Encoder	Ch A	C	I0.6
2	Pulses	Ch B	D	I0.7
3	Middle station Manual IN	Switch Middle Manual In/Out	3	I2.2

4	Middle station Manual OUT	Switch Middle Manual In/Out	4	I2.3
5	Middle station LIMIT switch	Middle LIMIT switch	8	I2.4
6	Middle Drive Fault	VFD Middle	MF	I2.5
7	N/U			I2.6
8	N/U			I2.7

BG3 PLC ANALOG INPUTS

INPUTS	Device	Wires##	PLC ADDRESS
Vacuum sensor Upper	Vacuum sensor UP/PLC Analog Inputs module	A+	AIW0
Vacuum sensor Lower	Vacuum sensor Low/PLC Analog Inputs module	B+	AIW2
Vacuum sensor Middle		C+	AIW4

BG3 PLC DIGITAL OUTPUTS

	OUTPUTS	Device	Wires #	PLC ADDRESS
1	Upper move Out	Relay Uout/VFD Upper	UOUT	Q0.0
2	Upper move IN	Relay Uin /VFD Upper	UIN	Q0.2
3	Upper slow motion	Relay Uslow/ VFD Upper	USL	Q0.4
4	Lower move Out	Relay Lout/ VFD Lower	LOUT	Q0.1
5	Lower move IN	Relay Lin/ VFD Lower	LIN	Q0.3
6	Lower slow motion	Relay Lslow VFD Lower	LSL	Q0.5
7	Middle move Out	Relay Mout/ VFD Middle	MOUT	Q0.6

8	Middle move IN	Relay Min/ VFD Middle	MIN	Q0.7
9	Middle slow motion	Relay Mslow VFD Middle	MSL	Q1.0
10	N/U			Q1.1

BG3 ANALOG OUTPUTS

Outputs	Control	Device	Wires##	VOLTAGE
Upper more vacuum	Upper more/less switch	Upper more/less motor	10	110VAC
Upper less vacuum	Upper more/less switch	Upper more/less motor	11	110VAC
Lower more vacuum	Lower more/less switch	Lower more/less motor	15	110VAC
Lower less vacuum	Lower more/less switch	Lower more/less motor	14	110VAC
Upper Quick dump	Upper Quick dump switch	Upper quick dump valve	16	110VAC
Lower Quick dump	Lower Quick dump Switch	Lower quick dump valve	18	110VAC
Blower ON/OFF	Blower Switch ON/OFF	Blower contactor	19	110VAC
Middle more vacuum	Middle more/less switch	Middle more/less motor	12	110VAC
Middle less vacuum	Middle more/less switch	Middle more/less motor	13	110VAC
Middle Quick dump	Middle Quick dump Switch	Middle quick dump valve	17	110VAC

POWER BUDGET

Triple Station

System power Budget		440VAC		15 Amp source
System requirements:	Units Number	Amps per unit	Total amps	
Transformer 440/110	1	0.73	0.73	
VFD drives 1 hp (2.5 A) 0.5 hp (1.4 A)	3	2.5(1.4)	7.5(4.2)	
Blower motor 5 hp 6.2 Amp 460VAC	1	6.2	6.2	
Total (A)=			14.43(11.13)	

24VDC Power Budget		24VDC		
Power supply on CPU	0.28 Amp		No fuse	
System requirements	Units Number	Amps per unit	Total amps	
relays (outputs)	9	0.007	0.063	
Total (A)=			0.063	

Power supply External	1.3 Amp		Fuse inputs 1.5 AMP	
System requirements	Units Number	Amps per unit	Total amps	
OIT	1	0.1	0.1	
DC/DC 24/12VDC	1	0.15	0.15	
CPU 224	1	0.9	0.9	
Extension Module 6ES7221-1BF20-0XA0	1	0.05	0.05	
Extension Module EM235	1	0.05	0.05	
Total (A)=			1.25	

110VAC		FUSE 4 AMP		
Power supply	3.33 Amp			
System requirements	Units Number	Amps per unit	Total amps	
110/24 power supply	1	0.48	0.48	
Blower starter	1	0.8	0.8	
Moreless vacuum motor	3	0.6	1.8	
Quick Dump solenoid	3	0.06	0.18	
Total(A)=			3.26	

12 VDC		Fuse 1 amps		
Power supply	1 Amp			
System requirements	Units Number	Amps per unit	Total amps	
Encoder	3	0.02	0.06	
Inputs	18	0.004	0.072	
Vacuum sensor ?	3	0.005	0.015	
Total (A)=			0.147	

Keys

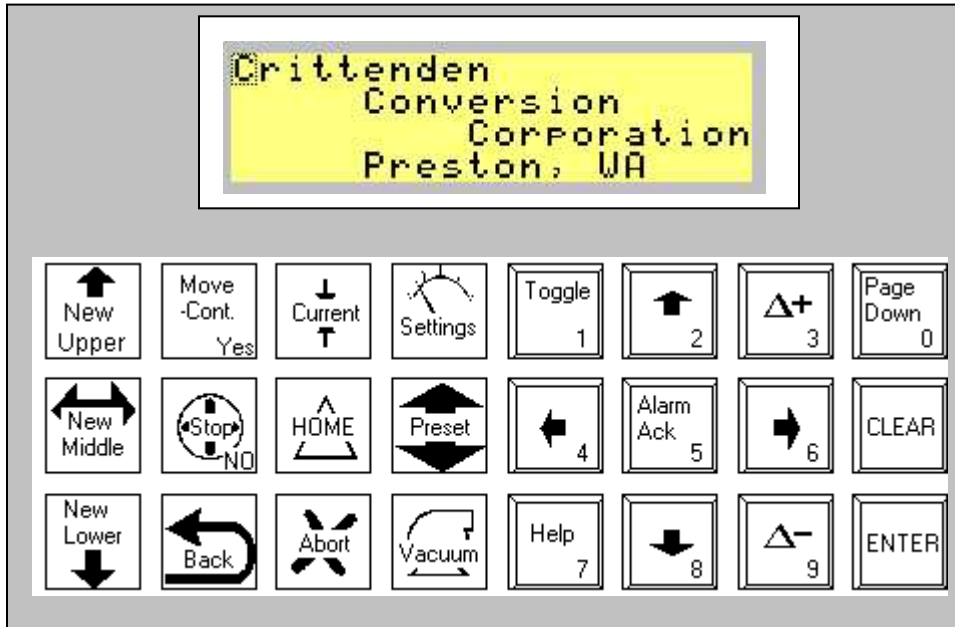

- Activate Home Procedure



- Enter NEW WIDTH for UPPER STATION



- Enter NEW WIDTH for MIDDLE STATION



- Enter NEW WIDTH for LOWER STATION

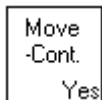

- Start Move or Continue or YES



- STOP MOTION or NO



- Move back to previous position

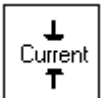

- Show current for UPPER and LOWER STATIONS



- ABORT all operation and reset controller



- Change settings (Password protected)



- Change preset and set preset

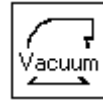

- Show vacuum values for UPPER and LOWER stations



- Get HELP on screen

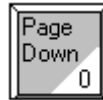

- Scroll available screens



- Clear value



- Enter value



- 3 or Increment value



- 9 or Decrement value



- 5 or alarm acknowledgement



- 2 or cursor UP



- 4 or cursor LEFT



- 6 or cursor RIGHT



- 8 or cursor DOWN



- 1 or Toggle ON/OFF settings

SCREENS

Screen #1

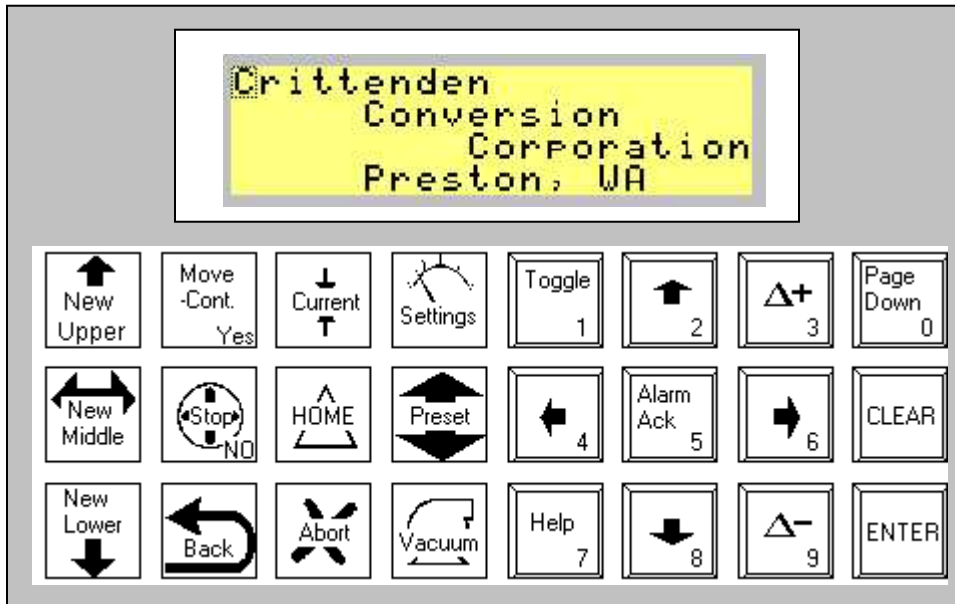

Screen Type:

Message

Start Up Screen

Control Buttons.

SDF8



- OPEN screen #17 "Move Home?"

No password

Chain screen.

Automatically go to the Screen #2 "Bridge Guide 2003 "

Time showed.

2 sec

Help screens.

Screen # 400

Screen #2

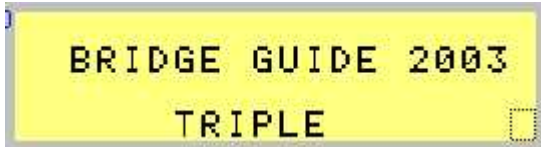

Screen Type:

Message

Control Buttons.



- Open Screen #17 "Move Home?"

No password

Chain screen.

Automatically go to the Screen #3 "Information 800-755-7894"

Time showed.

5 sec

Help screens.

Screen # 400

Screen #3

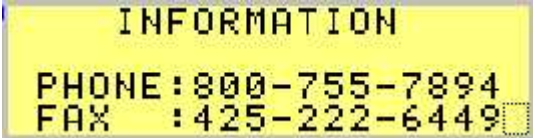

Screen Type:

Message

Control Buttons.

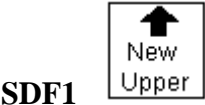

Screen #4 “Upper new Width?”
No password



Screen # 52 “Middle New Width”
No password



Screen # 23 “Low station new width”
No password

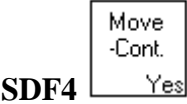

Open Screen # 34 “Current Width”
No password



Open Screen # 17 “HOME”



Open Screen # 1 “Start UP”



SDF7
Open Screen # 34 "Current Width"



SDF8
- Screen #17 "Move Home?"
No password
Chain screen.
Automatically go to the Screen #22 "Current WIDTH"
Time showed.
20 sec
Help screens.
Screen # 400

Screen #4

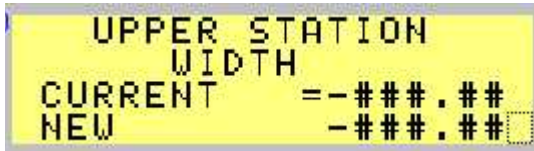

Screen Type:

Message

Control Buttons.



SDF2

Screen # 52 "Middle New Width"

No password



SDF3

Screen # 23 "Low station new width"

No password

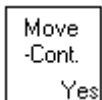

SDF4

Open Screen # 31 "Move from to "

No password



SDF5

Open Screen # 34 "Current width"



SDF6

Open Screen # Screen # 34 "Current width"



SDF7
Open Screen # 34 "Current Width"



SDF8
- Screen #17 "Move Home?"
No password

Chain screen.
Screen #34 "Current Width"
Time showed.
60 sec
Help screens.
Screen # 404

Screen #5



Screen Type:
Message Screen

Sound

Beep

Control Buttons.

SDF1 

Screen #4 "Upper new Width?"

No password

SDF7-  Open Screen # 34 "Current Width"

SDF8 

- Screen #17 "Move Home?"

No password

Chain screen.

#4 "New Upper Width"

Time showed.

10 sec

Help screens.

No

Screen #6

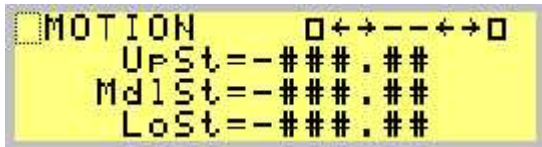

Screen Type:

Message

Control Buttons.



Stop motion



Back motion

Chain screen.

No

Time showed.

No

Help screens.

#406

Screen #7



Screen Type:

Message

Control Buttons.

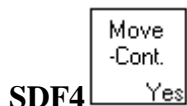

SDF4
Continue Motion



SDF5
Open Screen # 34 "Current Width"



SDF6
Return to privies position

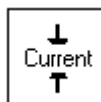

SDF7
Open Screen # 34 "Current Width"



SDF8
- Screen #17 "Move Home?"

Chain screen.

No

Time showed.

No

Help screens.

#407

Screen #8

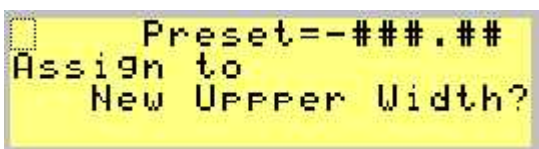

Screen Type:

Message

Control Buttons.



Screen #4 "Upper new Width?"

No password

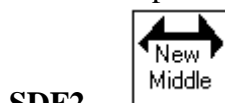

Screen # 52 "Middle New Width"

No password



Screen # 23 "Low station new width"

No password



Enter Preset

No password



Open Screen # 34 "Current Width"



Open Screen # 34 "Current Width"

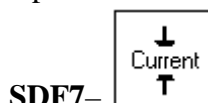

Open Screen # 34 "Current Width"

SDF8



- Screen #17 “Move Home?”

Chain screen.

Forward #55

Backward #33

Time showed.

No

Help screens.

No

Screen # 9

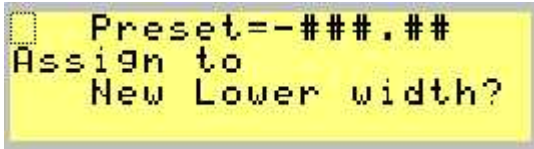

Screen Type:

Message

Control Buttons.



Screen #4 "Upper new Width?"

No password

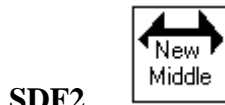

Screen # 52 "Middle New Width"

No password



Screen # 23 "Low station new width"

No password

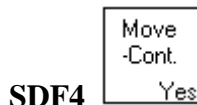

No password



Open Screen # 38 "Swap Width"



Open Screen # 34 "Current Width"

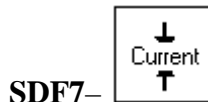

Open Screen # 34 "Current Width"

SDF8



- Screen #17 “Move Home?”

Chain screen.

Forward #38

Backward #56

Time showed.

No

Help screens.

No

Screen #10



Screen Type:

Message

Sound .

Beep.

Control Buttons.



SDF8

Screen #17 "Move Home?"

No password

Chain screen.

Screen #17

Time showed.

255 sec

Help screens.

410

Screen #11



Screen Type:

Message

Sound .

Beep.

Control Buttons.



SDF8

Screen #17 "Move Home?"

No password

Chain screen.

Screen #17

Time showed.

Help screens.

#411

Screen #12



Screen Type:

Message

Sound .

No

Control Buttons.



SDF1

Screen #4 "Upper new Width?"

No password



SDF2

Screen # 52 "Middle New Width"

No password



SDF3

Screen # 23 "Low station new width"

No password

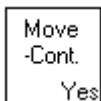

SDF4

Open Screen # 34 "Current Width"

No password



SDF5

Open Screen # 34 "Current Width"

No password



SDF6

Open Screen # 34 "Current Width"

No password

SDF7 

Open Screen # 34 "Current Width"

SDF8 

- Screen #17 "Move Home?"

No password

Chain screen.

Forward #34,

Backward #

Time showed.

Help screens.

Screen #13



Screen Type:

Message

Sound .

Beep

Control Buttons.



SDF8

Screen #17 "Move Home?"

No password

Chain screen.

No

Time showed.

No

Help screens.

#413

Screen #14



Screen Type:
Message

Sound .
No

Control Buttons.



SDF4
Screen #17 "Move Home?"
No password



SDF5
DEMO continue

Chain screen.

Time showed.
sec

Help screens.
#414

Screen #15



Screen Type:

Message

Sound .

No

Control Buttons.



SDF1

Screen #4 "Upper new Width?"

No password



SDF2

Screen # 52 "Middle New Width"

No password



SDF3

Screen # 23 "Low station new width"

No password



SDF4

Start DEMO

No password



SDF5

Open Screen # 24 "Set all to default"

No password



SDF6

Open Screen # 34 "Current Width"

No password



SDF7
Open Screen # 34 "Current Width"



SDF8
- Screen #17 "Move Home?"
No password
Chain screen.
FORWARD #24
BACKWARD #45
Time showed 5 sec
Help screens.415

Screen #16



Screen Type:

Message

Sound .

No

Control Buttons.



STOP

Chain screen.

No

Time showed.

No

Help screens.

No

Screen #17



Screen Type:

Message

Sound .

Beep

Control Buttons.

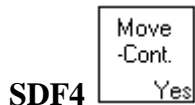

Move Home



Open Screen # 34 "Current Width"



Open Screen # 34 "Current Width"

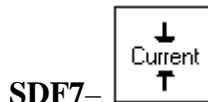

Open Screen # 34 "Current Width"

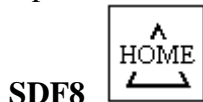

Screen #17 "Move Home?"

No password

Chain screen.

No

Time showed.

No

Help screens.

#417

Screen #18



Screen Type:

Alarm

Sound .

Continuous Beep

Control Buttons.



SDF8

Screen #17 "Move Home?"

No password

Chain screen.

No

Time showed.

No

Help screens.

Screen #19

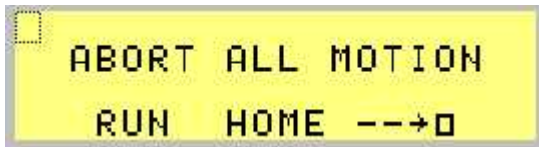

Screen Type:

Message

Sound .

Beep



SDF4

Screen #17 "Move Home?"

No password



SDF5

Open Screen # 34 "Current Width "

Control Buttons.



SDF8

Screen #17 "Move Home?"

No password

Chain screen.

17

Time showed.

No

Help screens.

#419

Screen #20

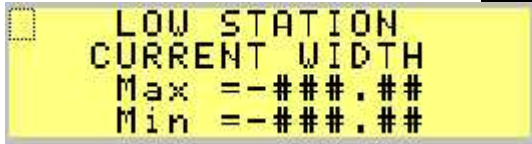

Screen Type:

Message

Sound .

No

Control Buttons.



SDF1

Screen #4 "Upper new Width?"

No password



SDF2

Screen # 52 "Middle New Width"

No password



SDF3

Screen # 23 "Low station new width"

No password

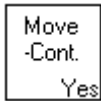

SDF4

Start DEMO

No password



SDF5

Open Screen # 24 "Set all to default"

No password



SDF6

Open Screen # 34 "Current Width"

No password

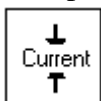

SDF7

Open Screen # 34 "Current Width"



- Screen #17 "Move Home?"

Chain screen.

Forward #57

Backward #22

Time showed.

5 sec

Help screens.

#420

Screen #21



Screen Type:

Message

Sound .

No

Control Buttons.



SDF5

STOP

Chain screen.

No

Time showed.

No

Help screens.

No

Screen #22

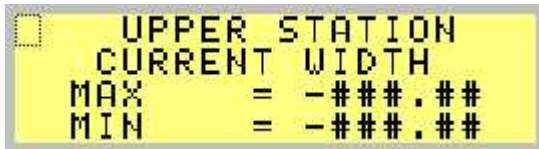

Screen Type:

Message

Sound .

No

Control Buttons.



SDF1

Screen #4 "Upper new Width?"

No password



SDF2

Screen # 52 "Middle New Width"

No password



SDF3

Screen # 23 "Low station new width"

No password

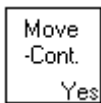

SDF4

Current width

No password



SDF5

Open Screen # 24 "Set all to default"

No password



SDF6

Open Screen # 34 "Current Width"

No password

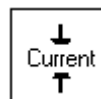

SDF7

Open Screen # 34 "Current Width"



- Screen #17 "Move Home?"

Chain screen.

Forward #20

Backward #3

Time showed.

5 sec

Help screens.

#420

Screen #23

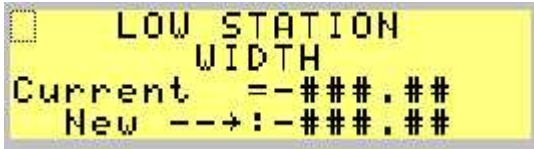

Screen Type:

Message

Sound .

No

Control Buttons.



SDF1

Screen #4 "Upper new Width?"

No password



SDF2

Screen # 52 "Middle New Width"

No password

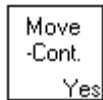

SDF4

Start motion

No password



SDF5

Open Screen # 24 "Set all to default"

No password



SDF6

Open Screen # 34 "Current Width"

No password

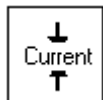

SDF7

Open Screen # 34 "Current Width"

SDF8



- Screen #17 "Move Home?"

Chain screen.

34

Time showed.

No

Help screens.

404

Screen #24



Screen Type:

Message

Sound .

No

Control Buttons.



SDF1

Screen #4 "Upper new Width?"

No password



SDF2

Screen # 52 "Middle New Width"

No password



SDF3

Screen # 23 "Low station new width"

No password

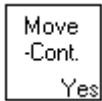

SDF4

Start set default values

No password



SDF5

Open Screen # 24 "Set all to default"

No password



SDF6

Open Screen # 34 "Current Width"

No password



SDF7
Open Screen # 34 "Current Width"



SDF8
- Screen #17 "Move Home?"

Chain screen.

#47

Time showed.

20 sec

Help screens.

#403

Screen #25



Screen Type:

Message

Sound .

Beep

Control Buttons.



SDF8

Screen #17 "Move Home?"

No password

Chain screen.

17

Time showed.

No

Help screens.

#425

Screen #26

```
HOME MinWidth
MEASURE Up/S:-###.##
AND Mdl/S:-###.##
ENTER Low/S:-###.##
```

Screen Type:

Message

Sound .

Beep

Control Buttons.

Move
-Cont.
Yes

SDF4

Continue

No password

^
HOME
v

SDF8

Screen #17 "Move Home?"

No password

Chain screen.

No

Time showed.

No

Help screens.

#426

Screen # 27

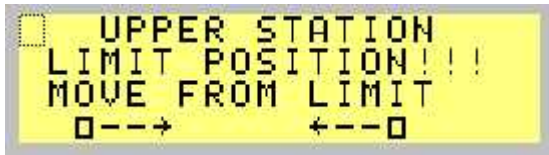

Screen Type:

Message

Sound .

NO

Control Buttons.

Chain screen.

Time showed.

No

Help screens.

427

Screen #28



Screen Type:

Message

Sound .

Beep

Control Buttons.

Chain screen.

Time showed.

No

Help screens.

428

Screen #29



Screen Type:

Message

Sound .

NO

Control Buttons.

Chain screen.

Time showed.

No

Help screens.

427

Screen #30



Screen Type:
Message

Sound .
NO

Control Buttons.



Move

No password



Open Screen # 34 "Current Width"



Open Screen # 34 "Current Width"

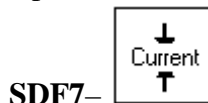

Open Screen # 34 "Current Width"



Screen #17 "Move Home?"

No password

Chain screen.

NO

Time showed.

No

Help screens. 405

Screen #31

```
MOVE FROM [ ] TO?
U/S=-###.## :-###.##
M/S=-###.## :-###.##
L/S=-###.## :-###.##
```

Screen Type:

Message

Sound .

NO

Control Buttons.



SDF1

Screen #4 "Upper new Width?"

No password



SDF2

Screen # 52 "Middle New Width"

No password



SDF3

Screen # 23 "Low station new width"

No password

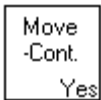

SDF4

Move

No password



SDF5

Open Screen # 24 "Set all to default"

No password



SDF6

Open Screen # 34 "Current Width"

No password



SDF7
Open Screen # 34 "Current Width"



SDF8
- Screen #17 "Move Home?"

Chain screen.

34

Time showed.

No

Help screens.

431

Screen #32



Screen Type:

Message

Sound .

NO

Control Buttons.

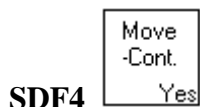

Yes change settings

No password



Open Screen # 34 "Current Width"



Open Screen # 34 "Current Width"

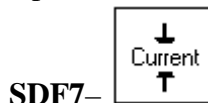

Open Screen # 34 "Current Width"

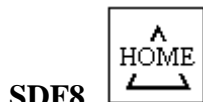

Screen #17 "Move Home?"

No password

Chain screen.

Time showed.

No

Help screens.

Screen #33

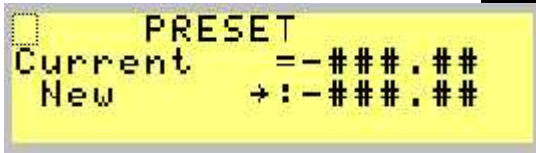

Screen Type:

Message

Sound .

NO

Control Buttons.



SDF1

Screen #4 "Upper new Width?"

No password



SDF2

Screen # 52 "Middle New Width"

No password



SDF3

Screen # 23 "Low station new width"

No password

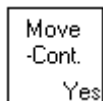

SDF4

Continue

No password



SDF5

Open Screen # 24 "Set all to default"

No password



SDF6

Open Screen # 34 "Current Width"

No password

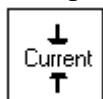

SDF7

Open Screen # 34 "Current Width"



- Screen #17 "Move Home?"

Forward #8

Backward #40

Time showed.

No

Help screens.

433

Screen #34

	CURRENT	WIDTH
UPPER	=-###.##	
MIDDLE	=-###.##	
LOWER	=-###.##	

Screen Type:

Message

Sound .

NO

Control Buttons.



SDF1

Screen #4 "Upper new Width?"

No password



SDF2

Screen # 52 "Middle New Width"

No password



SDF3

Screen # 23 "Low station new width"

No password

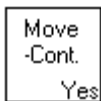

SDF4

Move to next widths

No password



SDF5

Open Screen # 24 "Set all to default"

No password



SDF6

Open Screen # 34 "Current Width"
No password



- Screen #17 "Move Home?"

Chain screen.

Forawrd #12

Backward #12

Time showed.

Help screens.

408

Screen #35

```
HOME MaxWidth
Measure U/S:-###.##
and ---->M/S:-###.##
Enter L/S:-###.##
```

Screen Type:

Message

Sound .

Beep

Control Buttons.

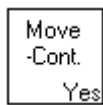

SDF4

YES continue after Max width entered



SDF5

Open Screen # 24 "Set all to default"

No password



SDF6

Open Screen # 34 "Current Width"

No password



SDF8

- Screen #17 "Move Home?"

Chain screen.

NO

Time showed.

NO

Help screens.

NO

Screen #36



Screen Type:

Alarm

1 sec

Sound .

Beep.

Control Buttons.



SDF1

Screen #4 "Upper new Width?"

No password



SDF2

Screen # 52 "Middle New Width"

No password

No password



SDF6

Open Screen # 34 "Current Width"

No password

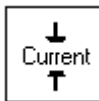

SDF7

Open Screen # 34 "Current Width"



SDF8

- Screen #17 "Move Home?"

Chain screen.

Screen #23

Time showed.

60 sec

Help screens.

#

Screen #37



Screen Type:

Alarm

1 sec

Sound .

Beep.

Control Buttons.



SDF8

Screen #17 "Move Home?"

No password

Chain screen.

Time showed.

60 sec

Help screens.

#

Screen #38

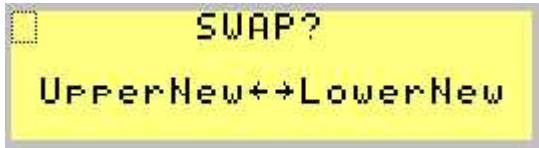

Screen Type:

Message

Sound .

NO

Control Buttons.



SDF1

Screen #4 "Upper new Width?"

No password



SDF2

Screen # 52 "Middle New Width"

No password



SDF3

Screen # 23 "Low station new width"

No password

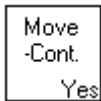

SDF4

Yes Swap

No password



SDF5

Open Screen # 24 "Set all to default"

No password



SDF6

Open Screen # 34 "Current Width"

No password

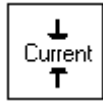

SDF7

Open Screen # 34 "Current Width"



SDF8

- Screen #17 "Move Home?"

Chain screen.

Forward #39

Backward #9

Time showed.

No

Help screens.

Screen #39

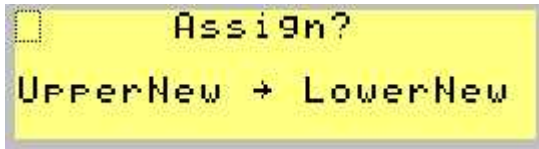

Screen Type:

Message

Sound .

NO

Control Buttons.



SDF1

Screen #4 "Upper new Width?"

No password



SDF2

Screen # 52 "Middle New Width"

No password



SDF3

Screen # 23 "Low station new width"

No password

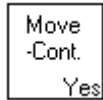

SDF4

Yes Assign

No password



SDF5

Open Screen # 24 "Set all to default"

No password



SDF6

Open Screen # 34 "Current Width"

No password



SDF7
Open Screen # 34 "Current Width"



SDF8
- Screen #17 "Move Home?"

Chain screen.

Forward #40

Backward #38

Time showed.

No

Help screens.

Screen #40



Screen Type:

Message

Sound .

NO

Control Buttons.



SDF1

Screen #4 "Upper new Width?"

No password



SDF2

Screen # 52 "Middle New Width"

No password



SDF3

Screen # 23 "Low station new width"

No password

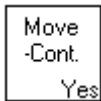

SDF4

Yes Assign

No password



SDF5

Open Screen # 24 "Set all to default"

No password



SDF6

Open Screen # 34 "Current Width"

No password

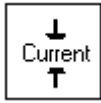

SDF7

Open Screen # 34 "Current Width"



SDF8

- Screen #17 "Move Home?"

Chain screen.

Forward #33

Backward #39

Time showed.

No

Help screens.

Screen #41

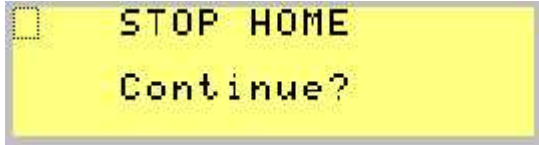

Screen Type:

Message

Sound .

NO

Control Buttons.

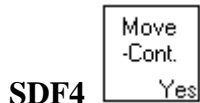

Yes

No password



Open Screen # 34



Open Screen # 17

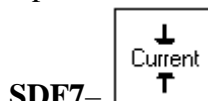

Open Screen # 34 "Current Width"

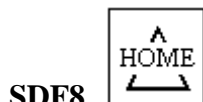

Screen #17 "Move Home?"

No password

Chain screen.

Time showed.

No

Help screens.

Screen #42



Screen Type:

Message

Sound .

NO

Control Buttons.



SDF1

Screen #4 "Upper new Width?"

No password



SDF2

Screen # 52 "Middle New Width"

No password



SDF3

Screen # 23 "Low station new width"

No password

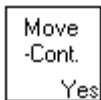

SDF4

Vacuum #43

No password



SDF5

Open Screen # 24 "Set all to default"

No password



SDF6

Open Screen # 34 "Current Width"

No password



SDF7
Open Screen # 34 "Current Width"



SDF8
- Screen #17 "Move Home?"

Chain screen.

#34

Time showed.

No

Help screens.

Screen #43

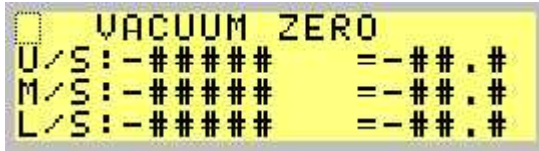

Screen Type:

Message

Sound .

NO

Control Buttons.



SDF6

Open Screen # 34

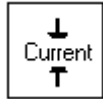

SDF7-

Open Screen # 34 "Current Width"



SDF8

Screen #17 "Move Home?"

No password

Chain screen.

Forward #44

Backward #47

Time showed.

No

Help screens.

Screen #44



Screen Type:

Message

Sound .

NO

Control Buttons.



SDF6

Open Screen # 34

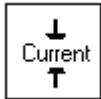

SDF7-

Open Screen # 34 "Current Width"



SDF8

Screen #17 "Move Home?"

No password

Chain screen.

Forward #45

Backward #43

Time showed.

No

Help screens.

Screen #45



Screen Type:

Message

Sound .

NO

Control Buttons.



SDF6

Open Screen # 34



SDF7-

Open Screen # 34 "Current Width"



SDF8

Screen #17 "Move Home?"

No password

Chain screen.

Forward #15

Backward #44

Time showed.

No

Help screens.

Screen #46

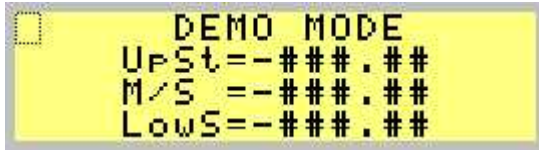

Screen Type:

Message

Sound .

NO

Control Buttons.



STOP DEMO

Chain screen.

Time showed.

No

Help screens.

Screen #47



Screen Type:

Message

Sound .

NO

Control Buttons.



- 2 or cursor UP



- 8 or cursor DOWN



- 1 or Toggle ON/OFF settings



SDF6

Open Screen # 34

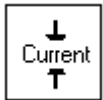

SDF7-

Open Screen # 34 "Current Width"



SDF8

Screen #17 "Move Home?"

No password

Chain screen.

Forward #43

Backward #0

Time showed.

10 sec

Help screens.

Screen #48



Screen Type:

Message

Sound .

3 beps

Control Buttons.

Chain screen.

Forward #43

Backward #0

Time showed.

10 sec

Help screens.

Screen #50



Screen Type:

Message

Sound .

3 beps

Control Buttons.

Chain screen.

Time showed.

Help screens.

Screen #51



Screen Type:

Message

Sound .

3 beps

Control Buttons.

Chain screen.

Time showed.

Help screens.

Screen #52

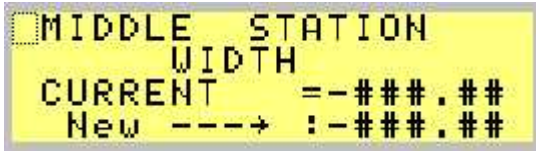

Screen Type:

Message

Sound .

3 beps

Control Buttons.



SDF1

Screen #4 "Upper new Width?"

No password

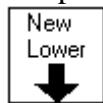

SDF3

Screen # 23 "Low station new width"

No password

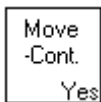

SDF4

Vacuum #43

No password



SDF5

Open Screen # 24 "Set all to default"

No password



SDF6

Open Screen # 34 "Current Width"

No password

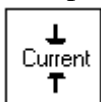

SDF7

Open Screen # 34 "Current Width"

SDF8



- Screen #17 “Move Home?”

Chain screen.

#34

Time showed.

Help screens.

Screen #53



Screen Type:

Message

Sound .

3 beps

Control Buttons.



- Screen #17 "Move Home?"

Chain screen.

Time showed.

Help screens.

Screen #54



Screen Type:
Message

Sound .
3 beps

Control Buttons.



SDF1
Screen #4 “Upper new Width?”
No password



SDF3
Screen # 23 “Low station new width”
No password

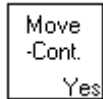

SDF4
Middle station width #52
No password



SDF5
Open Screen # 24 “Set all to default”
No password



SDF6
Open Screen # 34 “Current Width”
No password



Open Screen # 34 "Current Width"



- Screen #17 "Move Home?"

Chain screen.

Time showed.

Help screens.

Screen #55



Screen Type:

Message

Sound .

3 beps

Control Buttons.



SDF1

Screen #4 “Upper new Width?”

No password

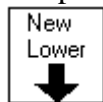

SDF3

Screen # 23 “Low station new width”

No password

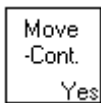

SDF4

Yes assign

No password



SDF5

Open Screen # 24 “Set all to default”

No password



SDF6

Open Screen # 34 “Current Width”

No password

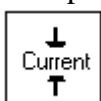

SDF7

Open Screen # 34 “Current Width”

SDF8



- Screen #17 “Move Home?”

Chain screen.

#56

Time showed.

Help screens.

Screen #56



Screen Type:

Message

Sound .

3 beps

Control Buttons.



SDF1

Screen #4 "Upper new Width?"

No password



SDF3

Screen # 23 "Low station new width"

No password

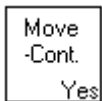

SDF4

Yes assign

No password



SDF5

Open Screen # 24 "Set all to default"

No password



SDF6

Open Screen # 34 "Current Width"

No password

Chain screen.

#9

Time showed.

Help screens.

Screen #57



Screen Type:

Message

Sound .

3 beps

Control Buttons.



SDF1

Screen #4 "Upper new Width?"

No password



SDF3

Screen # 23 "Low station new width"

No password



SDF4

#34

No password



SDF5

Open Screen # 24 "Set all to default"

No password



SDF6

Open Screen # 34 "Current Width"

No password

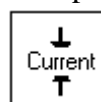

SDF7

Open Screen # 34 "Current Width"

SDF8



- Screen #17 “Move Home?”

Chain screen.

#17

Time showed.

Help screens.

#420

HELP SCREENS

Screen #400

Screen Type:

Help

```
Push "Home" to start  
INFORMATION  
PHONE:800-755-78947
```

Screen#403

Screen Type:

Help

```
 "YES"-Set all to  
Factory Default
```

Screen #404

Screen Type:

Help

```
Push "Clear" enter New  
width and "Enter"  
Use number keys or  
decrement/increment
```

Screen #405

Screen Type:

Help

```
"YES"-MoveBack  
"Other Choices"
```

Screen #406

Screen Type:

Help

```
"STOP"-to stop  
          motion
```

Screen #407

Screen Type:

Help

```
"Yes"-Continue  
"Back"-Move Back
```

Screen #408

Screen Type:

Help

```
USE ALL F.KEYS  
Page Down-Vacuum
```

Screen #410

Screen Type:

Help

```
PLC lost data from  
it's memory!Try Home
```

Screen #411

Screen Type:

Help

```
"Home"-only choice  
Check Encoder Power
```

Screen #413

Screen Type:

Help

```
Check Drive Error  
Power-Off-Start-Home
```

Screen #414

Screen Type:

Help

```
"Yes"-Stop "DEMO"  
"No"-Continue "DEMO"
```

Screen #415

Screen Type:

Help

```
"Yes"-Start "DEMO"
```

Screen #417

Screen Type:

Help

```
"YES"-StartHome  
"Other choices"
```

Screen #419

Screen Type:
Help

```
After "Abort" Run  
"HOME" to SetUp Sys.
```

Screen #420

Screen Type:
Help

```
To change Run Home
```

Screen #425

Screen Type:
Help

```
PLC lost data from  
it's memory Run Home
```

Screen #426

Screen Type:
Help

```
Measure and Enter  
correct values
```

Screen #427

Screen Type:

Help

```
Move guides from  
limit position
```

Screen #428

Screen Type:

Help

```
Open box and check  
error code on drive
```

Screen #431

Screen Type:

Help

```
Check values before  
"yes"-to start move
```

Screen #433

Screen Type:

Help

```
"Yes"-NewPRST→CRNT  
See other Pages→
```

APPENDIX

SCHEMATIC DIAGRAMS

- 1 BG3 CONTROL PANEL 3-PHASE SCHEMATIC
- 2 BG3 CONTROL PANEL 120VAC TO 24/12 VDC DISTRIBUTION
- 3 BG3 CONTROL PANEL PLC INPUTS MAIN MODULE
- 4 BG3 CONTROL PANEL VACUUM CONTROL SWITCHES SCHEMATIC
- 5 BG3 CONTROL PANEL EXTENSION MODULES INPUTS SCHEMATIC
Extension module EM 235-OKD22-0XA0 AI4/AO Configuration Switch Settings
- 6 BG3 CONTROL PANEL OUTPUTS SCHEMATIC
- 7 BG3 CONTROL PANEL TERMINAL STRIP WIRING SCHEMATIC
- 8 BG3 CONTROL PANEL BOX#1 TERMINAL STRIP WIRING SCHEMATIC
- 9 BG3 BLOWER 3-PHASE SCHEMATIC
- 10 MODEL MAR 8RH-8 120 50/60 0.6 AMP (VACUUM MORE/LESS)
- 11 BG-2003 - Vacuum Unit
- 12 DC-DC CONVERTER 24VDC/12VDC-VR-2002/12/10

ASSEMBLING DIAGRAMS

- 1 CONDUITS AND JUNCTION BOXES
 - 2 CABLES
 - 3 JUNCTION BOX #1
 - 4 MANUAL MOVE REMOTE CONTROL BOX
 - 5 JUNCTION BOX#3#13
 - 6 JUNCTION BOX#7
 - 7 JUNCTION BOX#9
 - 8 JUNCTION BOX#10
 - 9 JUNCTION BOX#12
 - 10 BG3 CONTROL PANEL FRONT INSIDE WIRING
- VARIABLE FREQUENCY DRIVE SM410 PARAMETER TABLE
OIT TROUBLESHOOTING

460 VAC 60 Hz 3-PHASE MAIN
POWER FEEDER 15 AMP

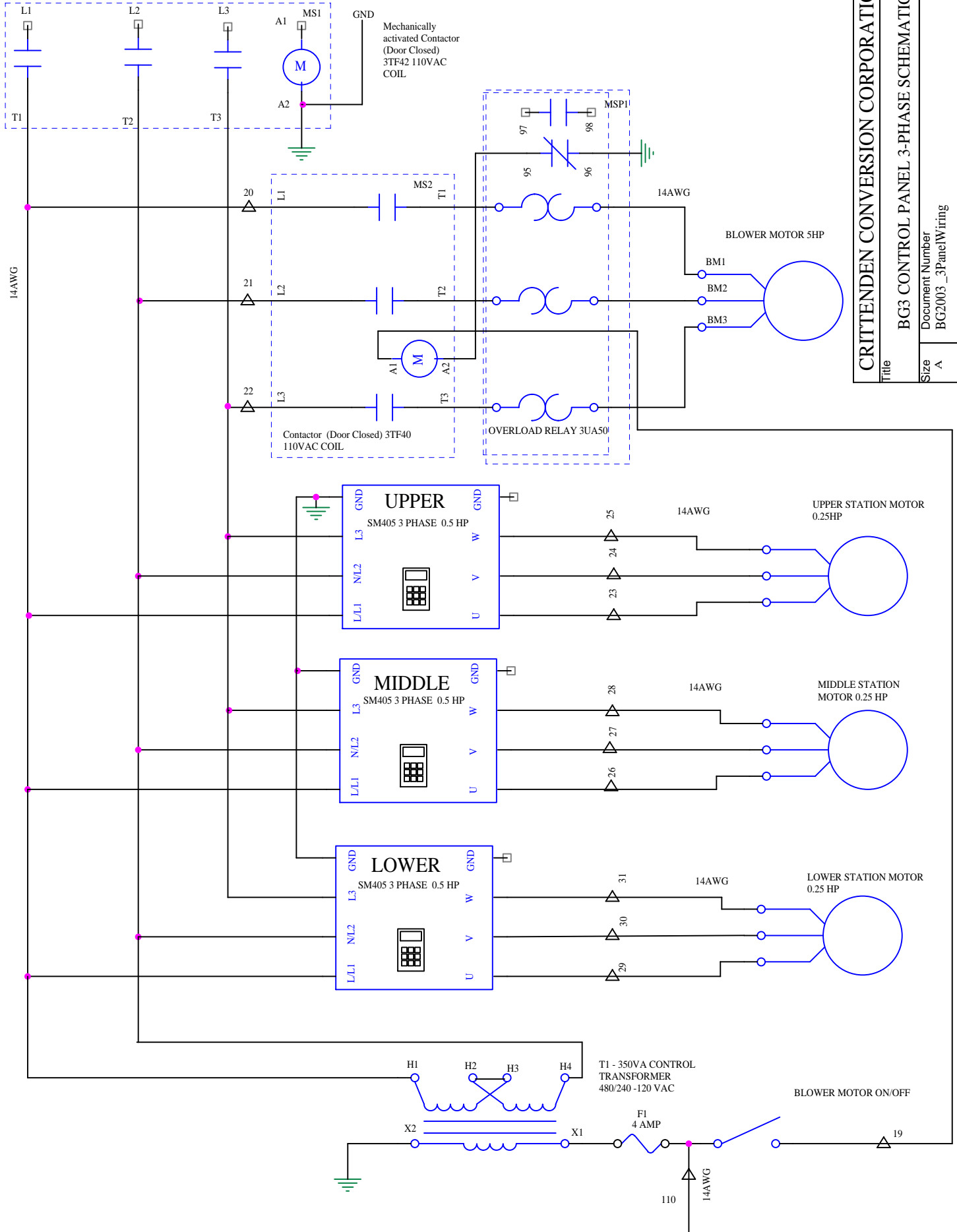

CRITTENDEN CONVERSION CORPORATION

Title		BG3 CONTROL PANEL 3-PHASE SCHEMATIC	
Size	A	Document Number	BG2003_3PanelWiring
Rev	A	Date:	Tuesday, December 05, 2006
Sheet	1	of	10

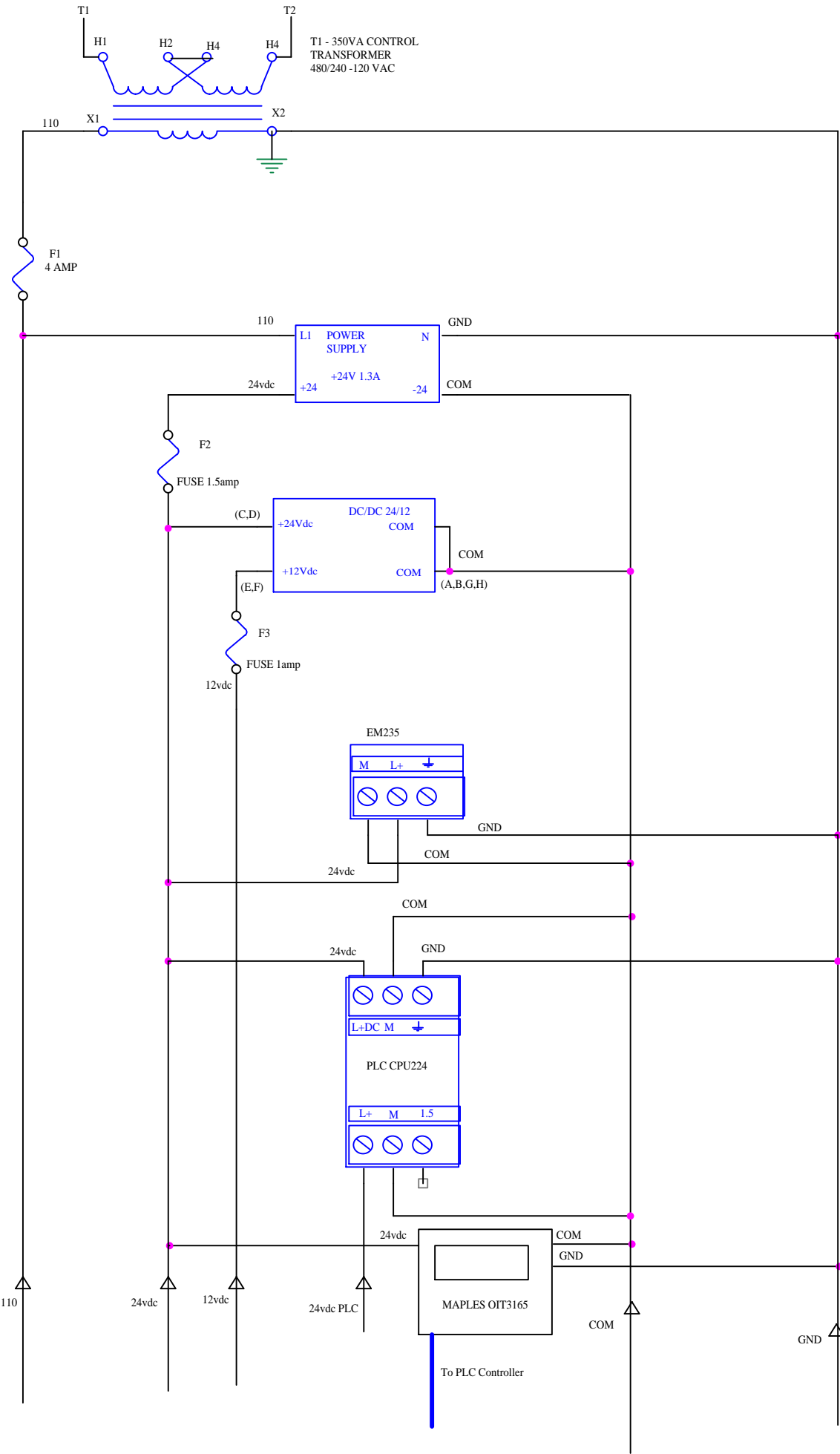

CRITTENDEN CONVERSION CORPORATION

Title: BG3 CONTROL PANEL 120VAC TO 24/12 VDC DISTRIBUTION

Size	A	Rev	A
Document Number	BG2003_3PanelWiring		

Date: Thursday, October 11, 2007 Sheet 2 of 10

+12VDC COM

PLC CPU-224 14 INPUTS

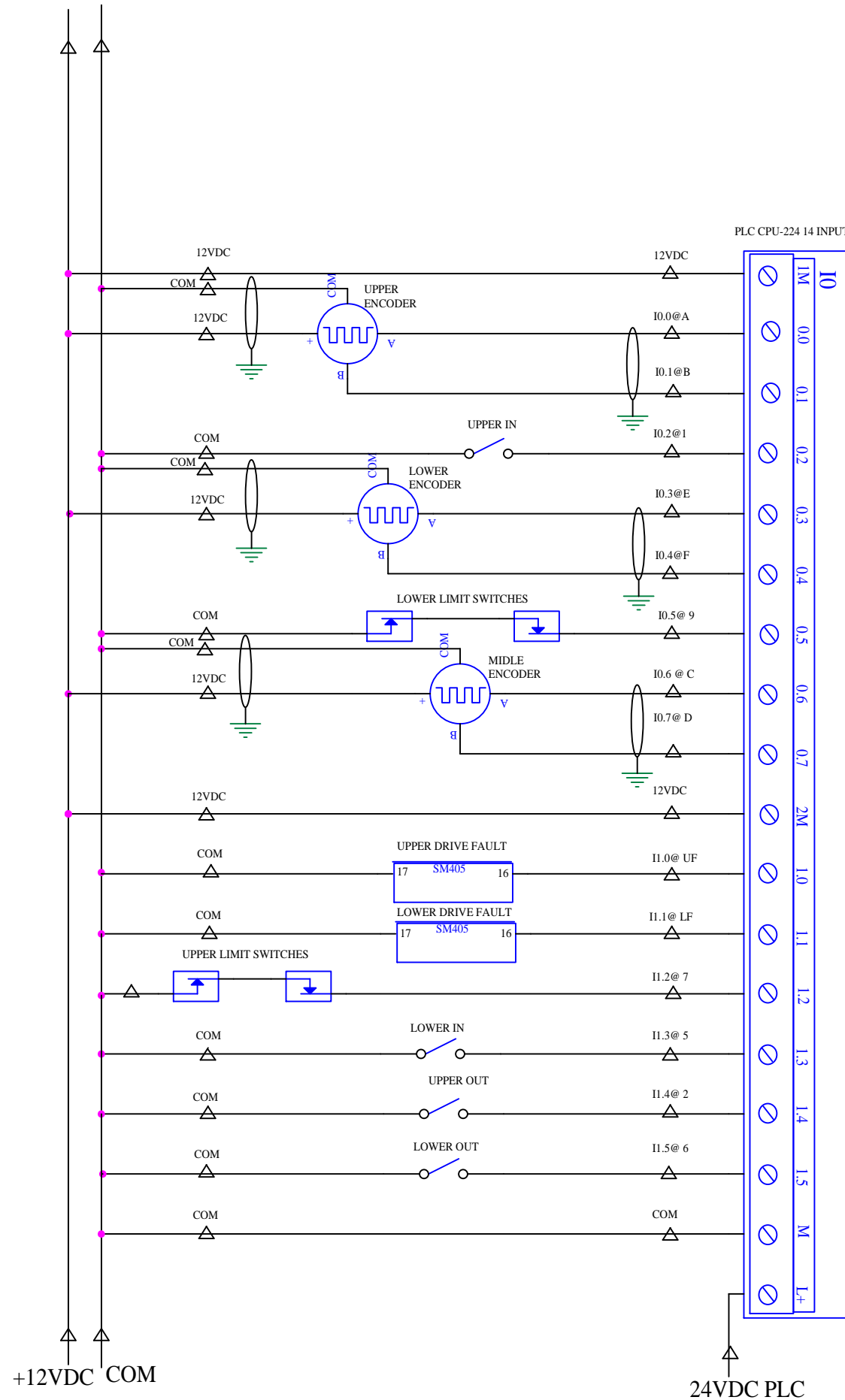

CRITTENDEN CONVERSION CORPORATION

Title BG3 CONTROL PANEL PLC INPUTS MAIN MODULE

Document Number BG2003 _3PanelWiring

Rev A

Date: Friday, November 14, 2003

Sheet 3 of 10

12VDC COM

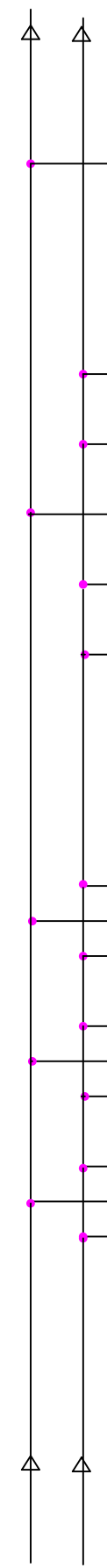

12VDC COM

EXTENSION MODULE 8 INPUTS EM221

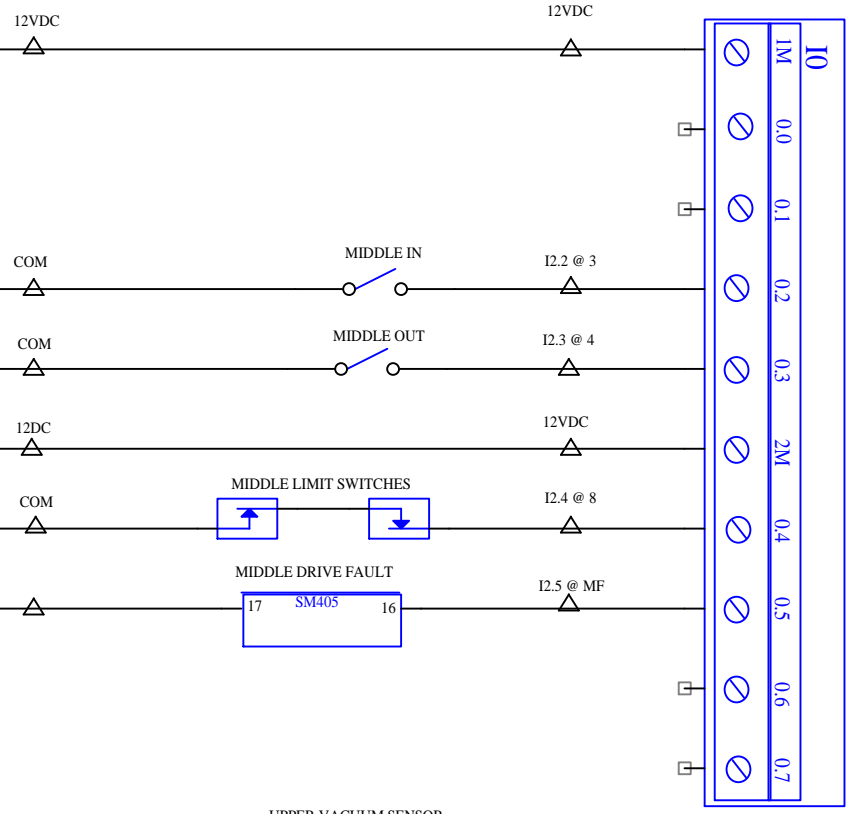

EXTENSION MODULE 4 ANALOG INPUTS EM235

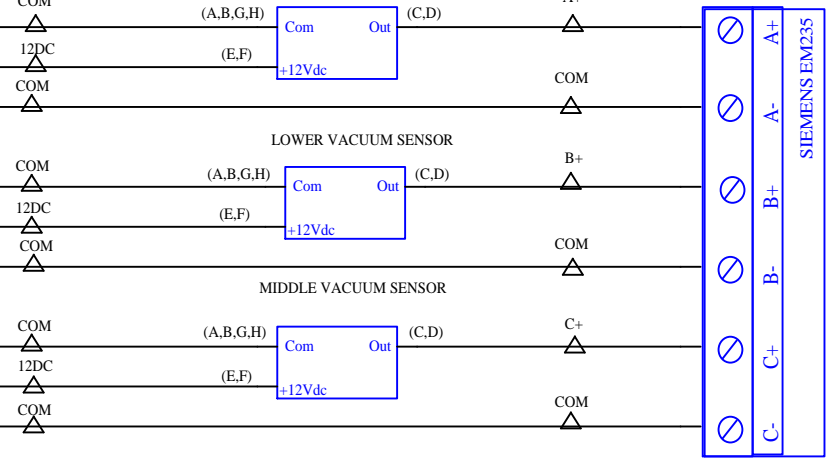

Extension module EM 235 Configuration Switch Settings



CRITTENDEN CONVERSION CORPORATION

Title		BG3 CONTROL PANEL EXTENSION MODULES INPUTS SCHEMATIC	
Size	A	Document Number	BG2003...3PanelWiring
Rev	A	Date:	Monday, May 10, 2004
Sheet		5	of 12

24VDC

24VDC

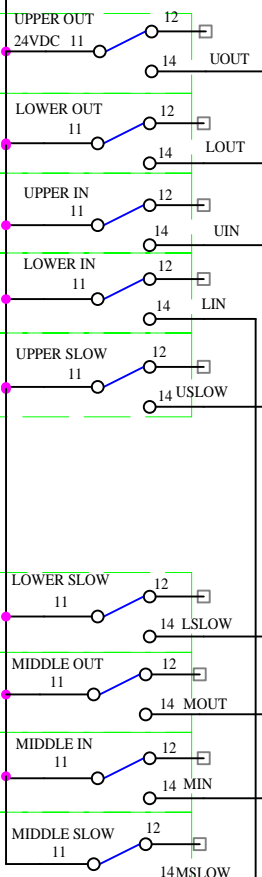
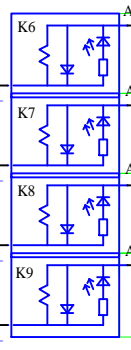
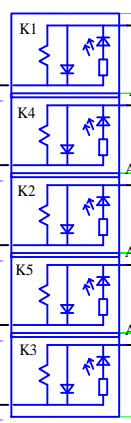
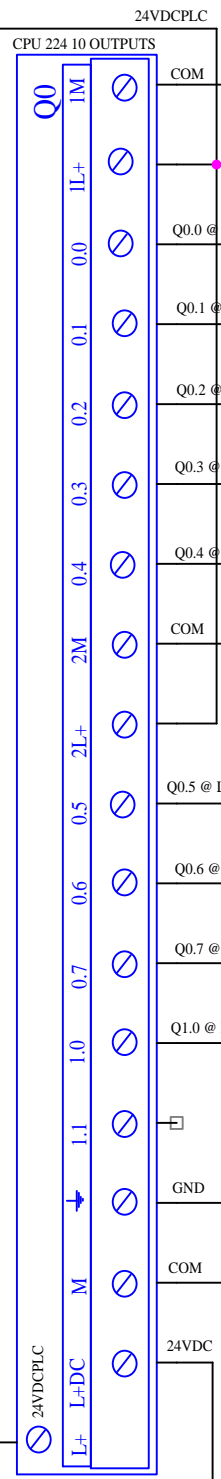

(See Page3) 11.0 @ UF

(See Page5) 12.5 @ MF

(See Page3) 11.1 @ LF

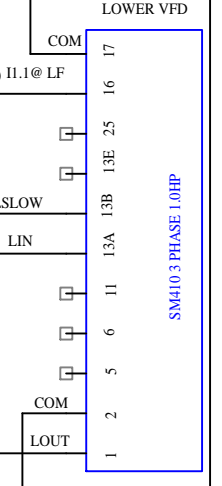
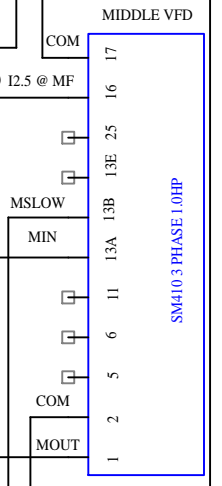
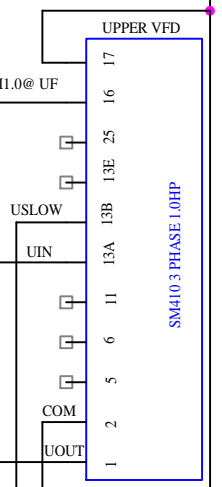

SM410 3 PHASE 1.0HP

SM410 3 PHASE 1.0HP

SM410 3 PHASE 1.0HP

CRITTENDEN CONVERSION CORPORATION

Title BG3 CONTROL PANEL OUTPUTS SCHEMATIC

Rev	A
Document Number	BG2003 _3PanelWiring
Size	A

Date:	Wednesday, September 13, 2006
Sheet	6 of 12

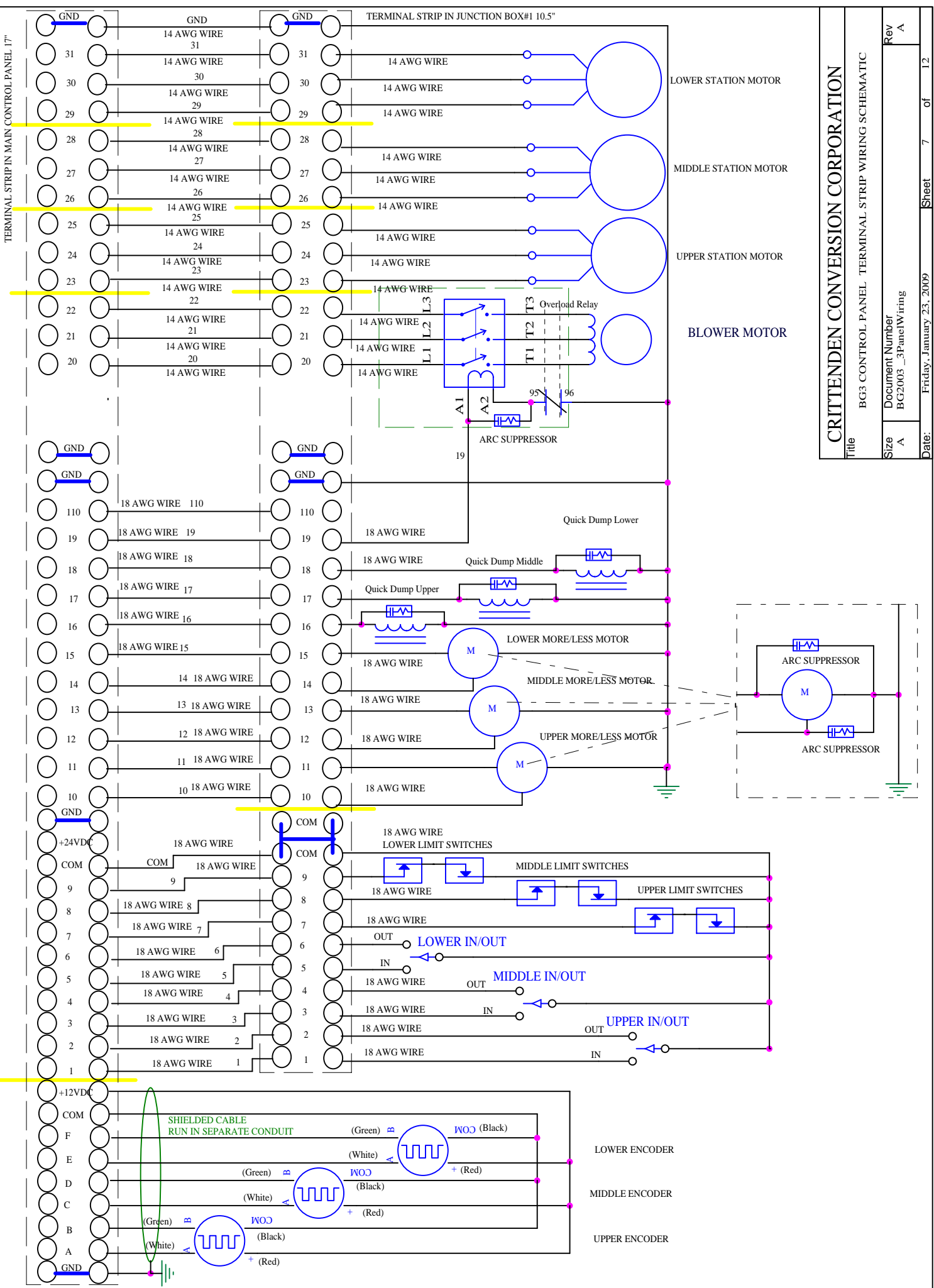

CRITTENDEN CONVERSION CORPORATION Title BG3 CONTROL PANEL TERMINAL STRIP WIRING SCHEMATIC		Rev	A
		Size	A
Document Number BG2003_3PanelWiring		Sheet	7 of 12
Date:		Friday, January 23, 2009	

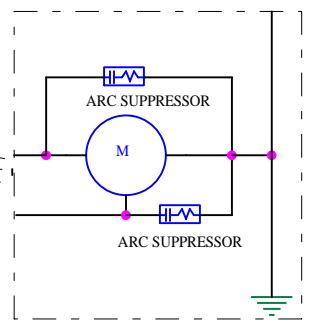

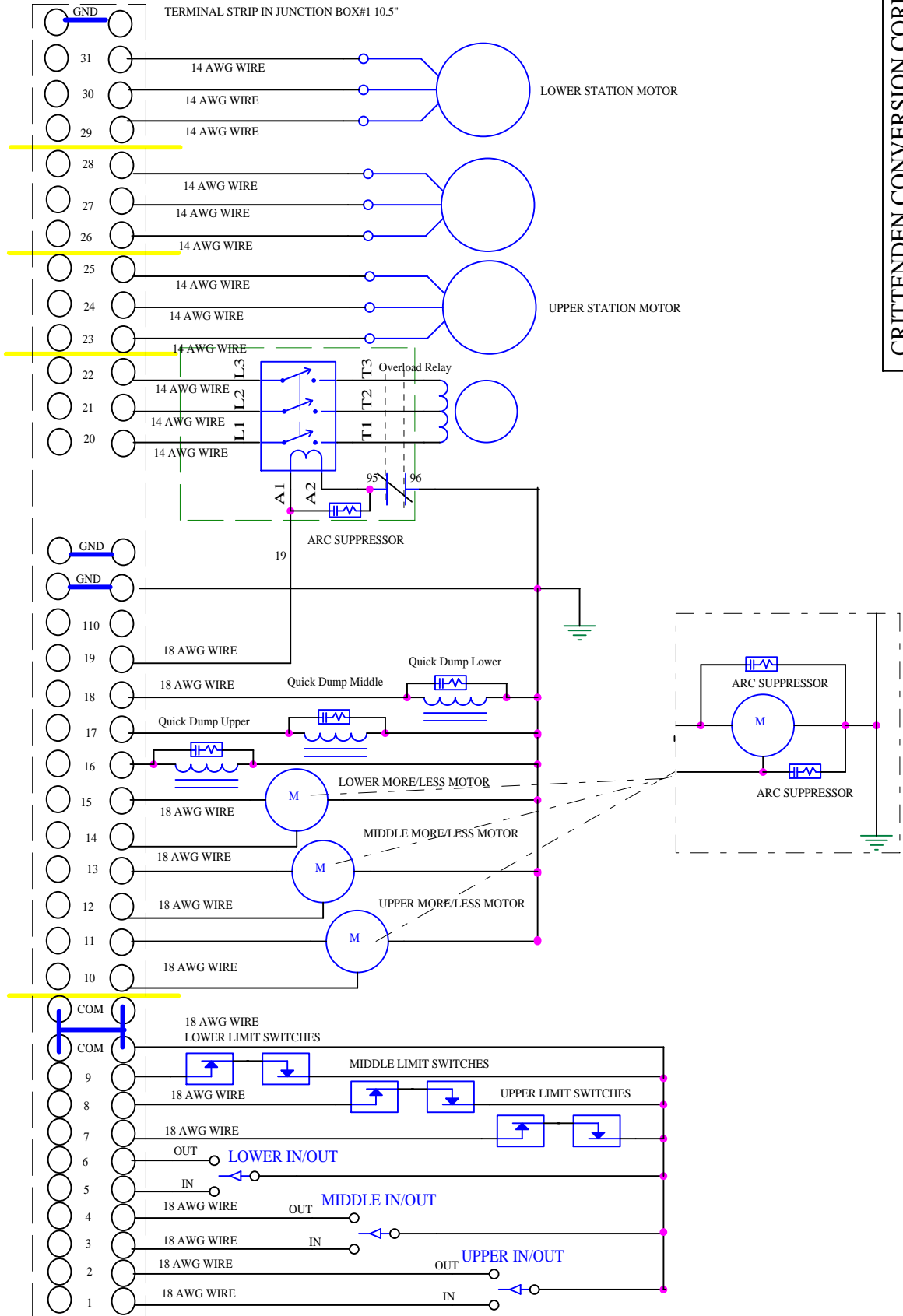

CRITTENDEN CONVERSION CORPORATION

Title: BG3 CONTROL PANEL BOX#1 TERMINAL STRIP WIRING SCHEMATIC

Size: A
 Document Number: BG2003...3PanelWiring
 Rev: A

Date: Friday, January 30, 2004
 Sheet: 8 of 12

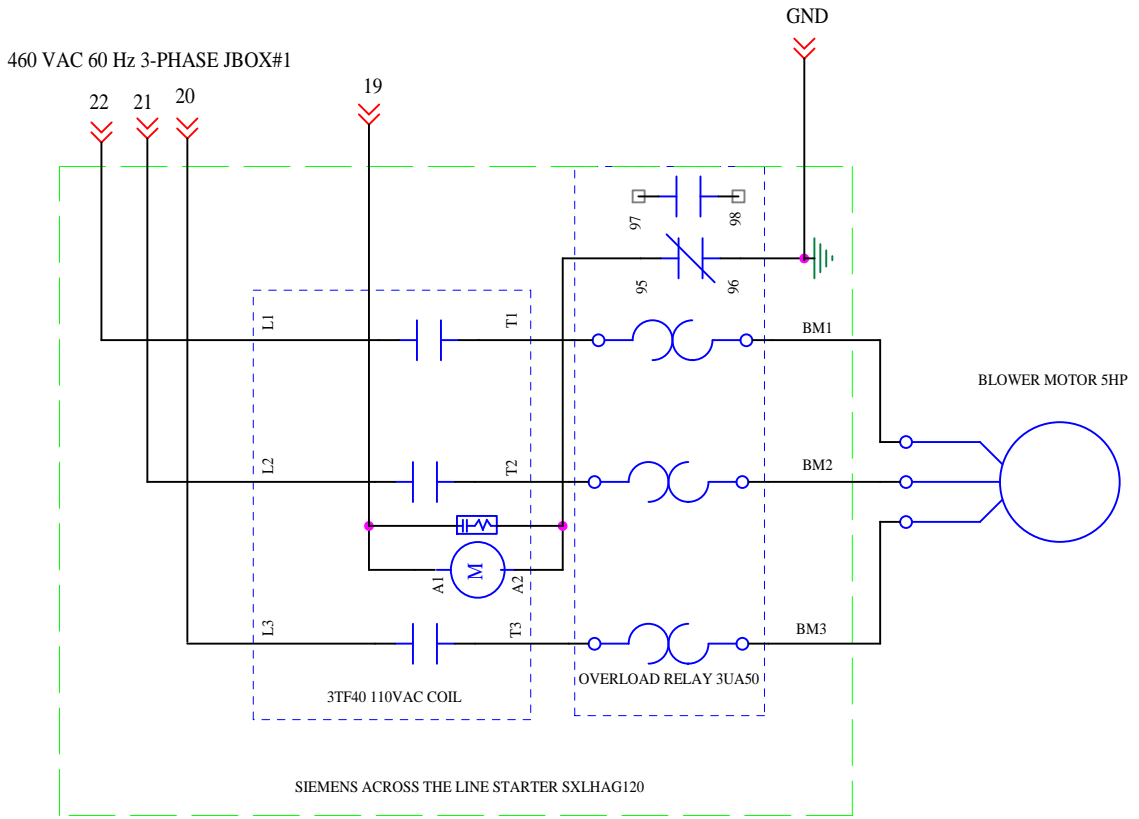

CRITTENDEN CONVERSION CORPORATION

Title BG3 BLOWER 3-PHASE SCHEMATIC

Size A Document Number BG2003 _3PanelWiring Rev A

Date: Wednesday, April 14, 2004 Sheet 9 of 12

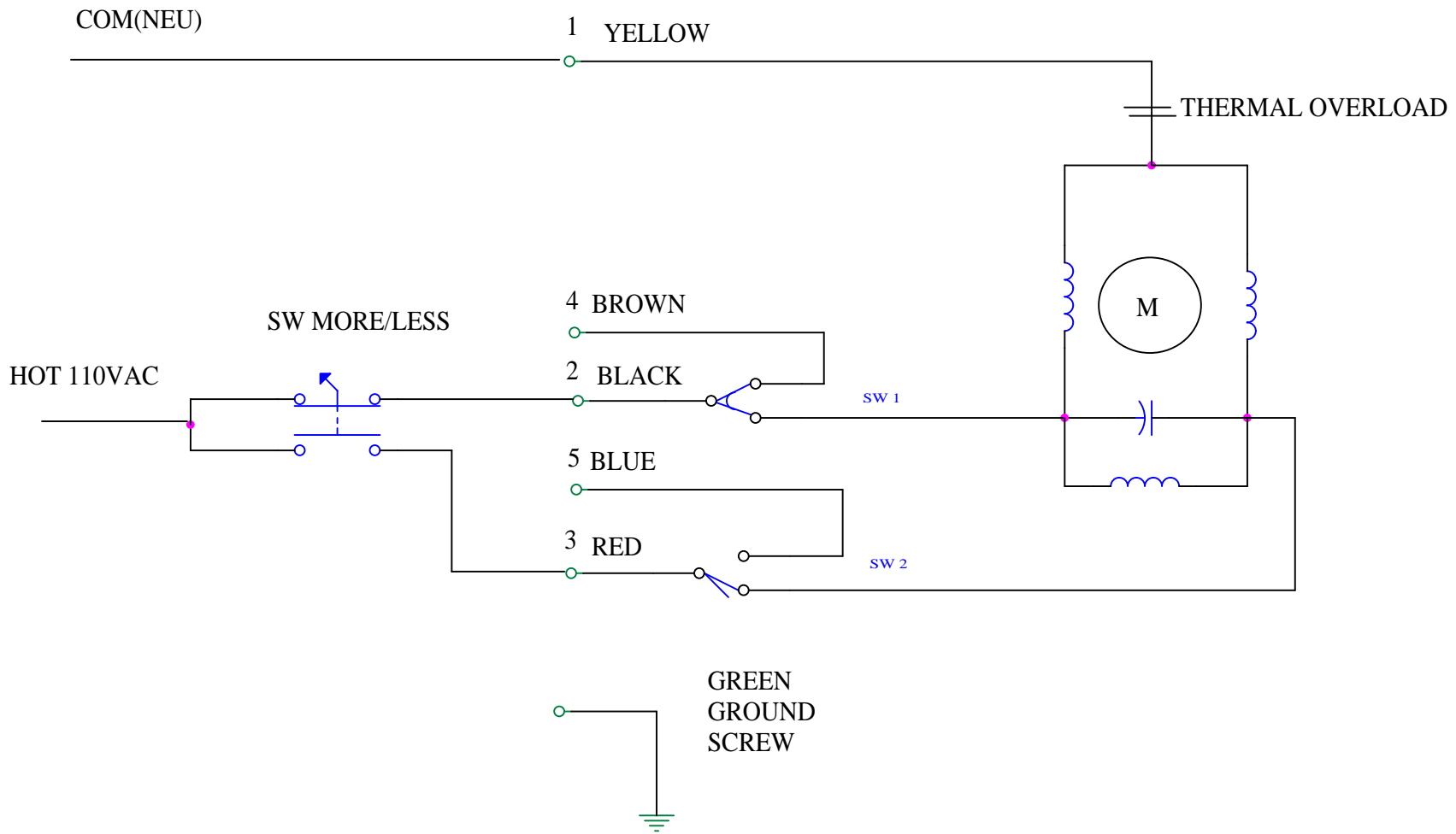

CRITTENDEN CONVERSION CORPORATION		
Title MODEL MAR 8RH-8 120 50/60 0.6 AMP (VACUUM MORE/LESS)		
Size A	Document Number BG3_3PANEL WIRING	Rev A
Date:	Friday, November 14, 2003	Sheet 10 of 12

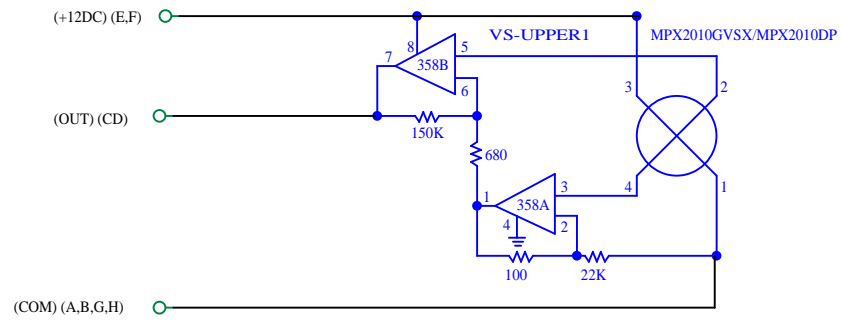

CRITTENDEN CONVERSION CORPORATION		
Title		
BG-2003 - Vacuum Unit		
Size	Document Number	Rev
A	BG2003 3-PANEL WIRING.DSN PAGE #11	A
Date:	Monday, June 02, 2008	Sheet 11 of 12

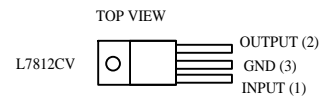
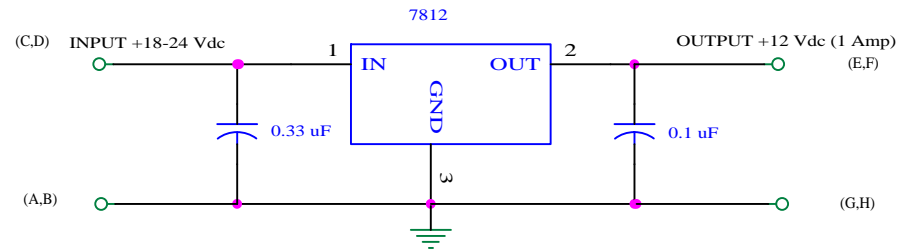

CRITTENDEN CONVERSION CORPORATION

Title DC-DC 24-12VDC CONVERTER VR PHOENIX

Size A Document Number DC-DC 24-12

Rev A

Date: Thursday, October 11, 2007 Sheet 12 of 12

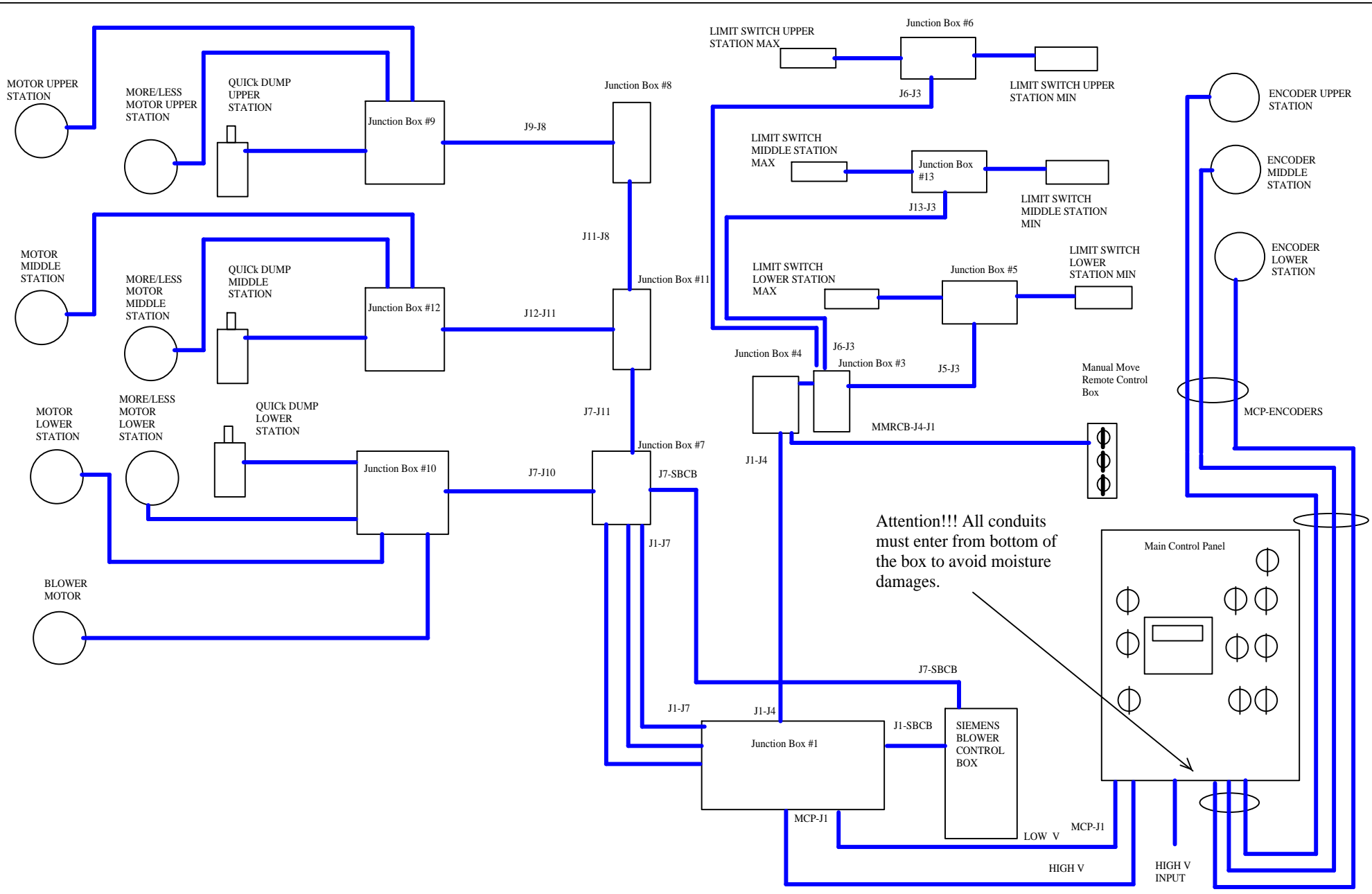

CRITTENDEN CONVERSION CORPORATION		
Title Bridge Guide 2003		
Size A	Document Number CONDUITS AND JUNCTION BOXES	Rev A
Date:	Wednesday, March 17, 2004	Sheet 1 of 10

MCP-J1

14 AWG WIRES

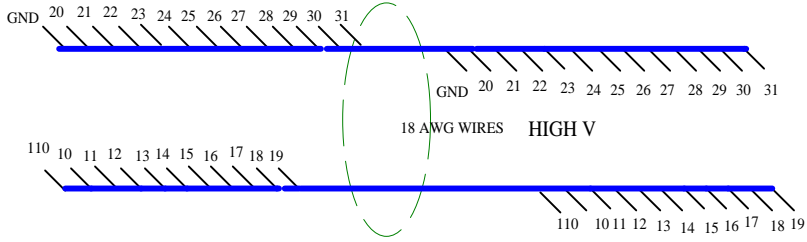

18 AWG WIRES RUNNING IN SEPARATE CONDUIT LOW V

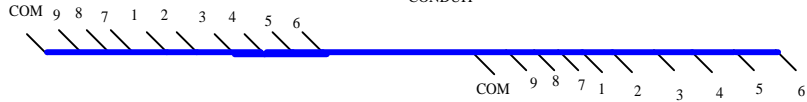

J1-SBCB

14 AWG WIRES

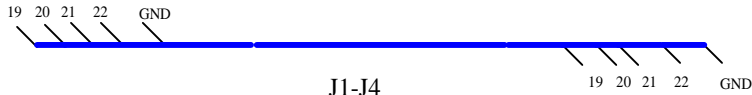

J1-J4

18 AWG WIRES



J7-SBCB

14 AWG WIRES

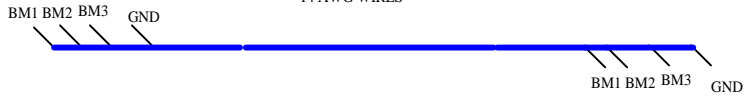

MMRCB-J4-J1

18 AWG WIRES

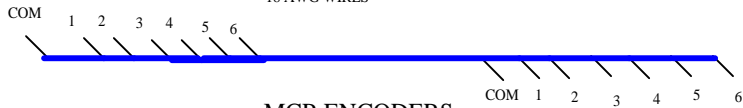

MCP-ENCODERS

20 AWG WIRES CABLE RUNNING IN SEPARATE CONDUIT

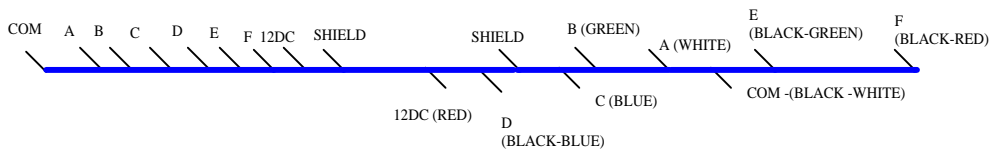

J1-J7

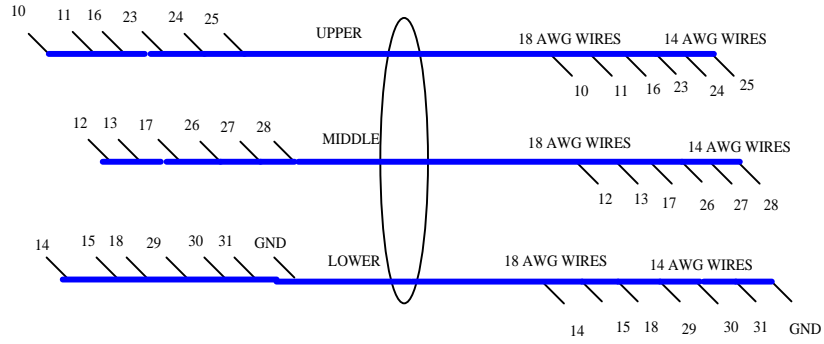

J7-J11

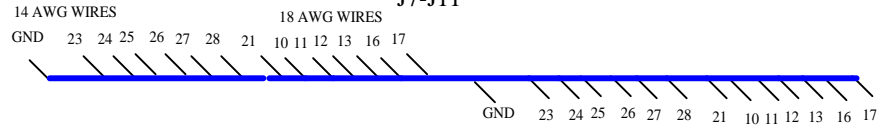

J11-J8

(J8-J9)

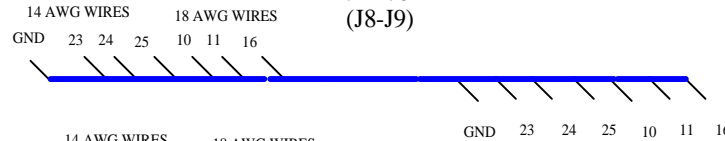

J12-J11



J7-J10

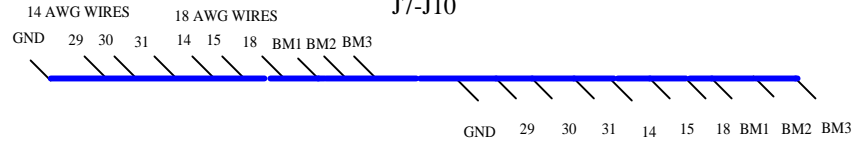

J3-J6

J3-J13

J3-J5

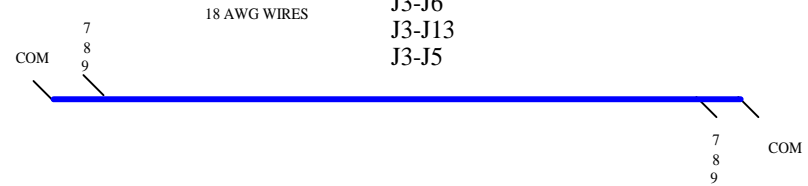

CRITTENDEN CONVERSION CORPORATION

Title
BRIDGE GUIDE 2003

Size
A Document Number
CABLES

Rev
A

Date: Friday, May 14, 2004 Sheet 2 of 10

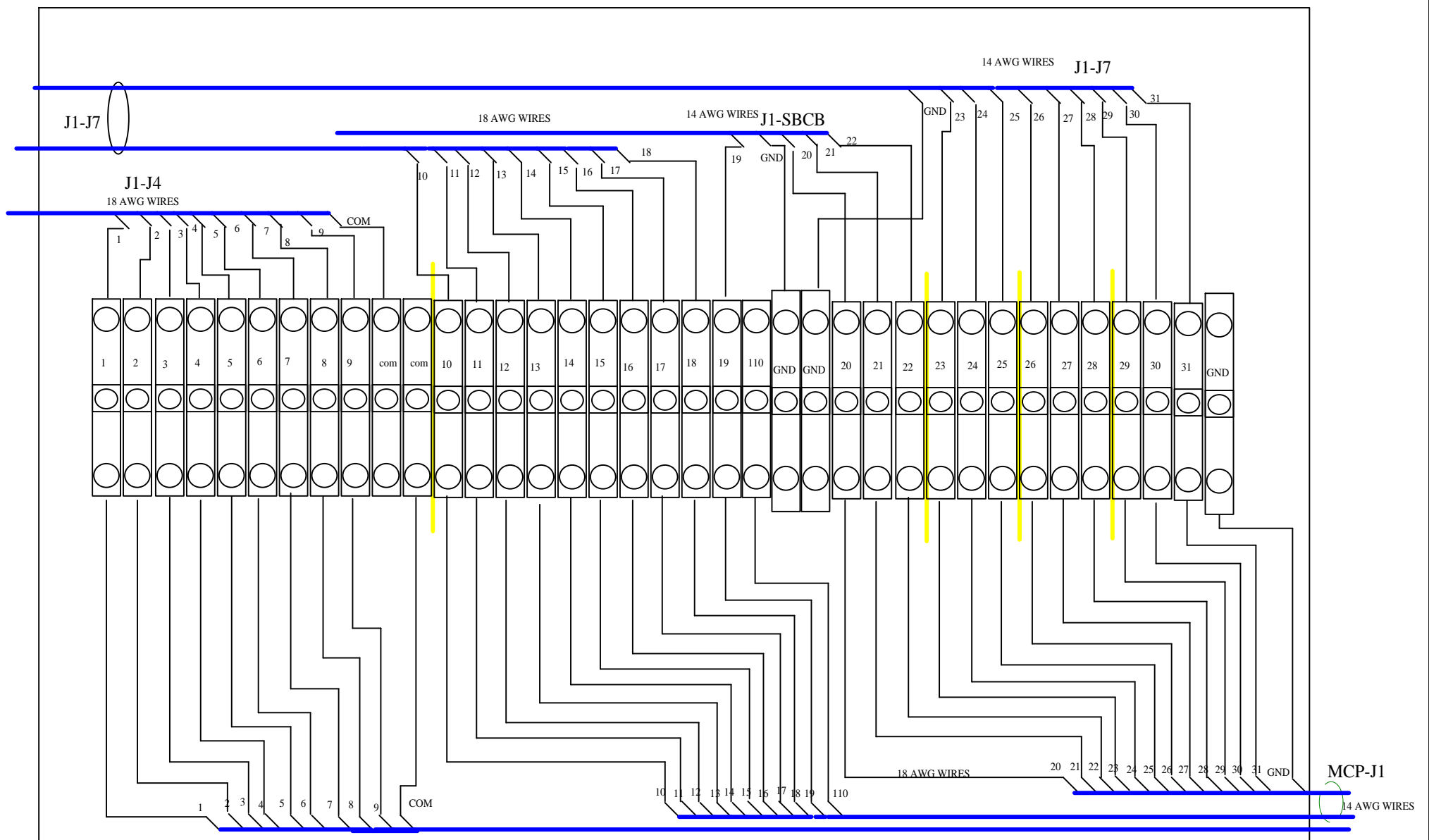

CRITTENDEN CONVERSION CORPORATION		
Title BRIDGE GUIDE 2003		
Size A	Document Number JUNCTION BOX #1	Rev A
Date:	Friday, November 14, 2003	Sheet 3 of 10

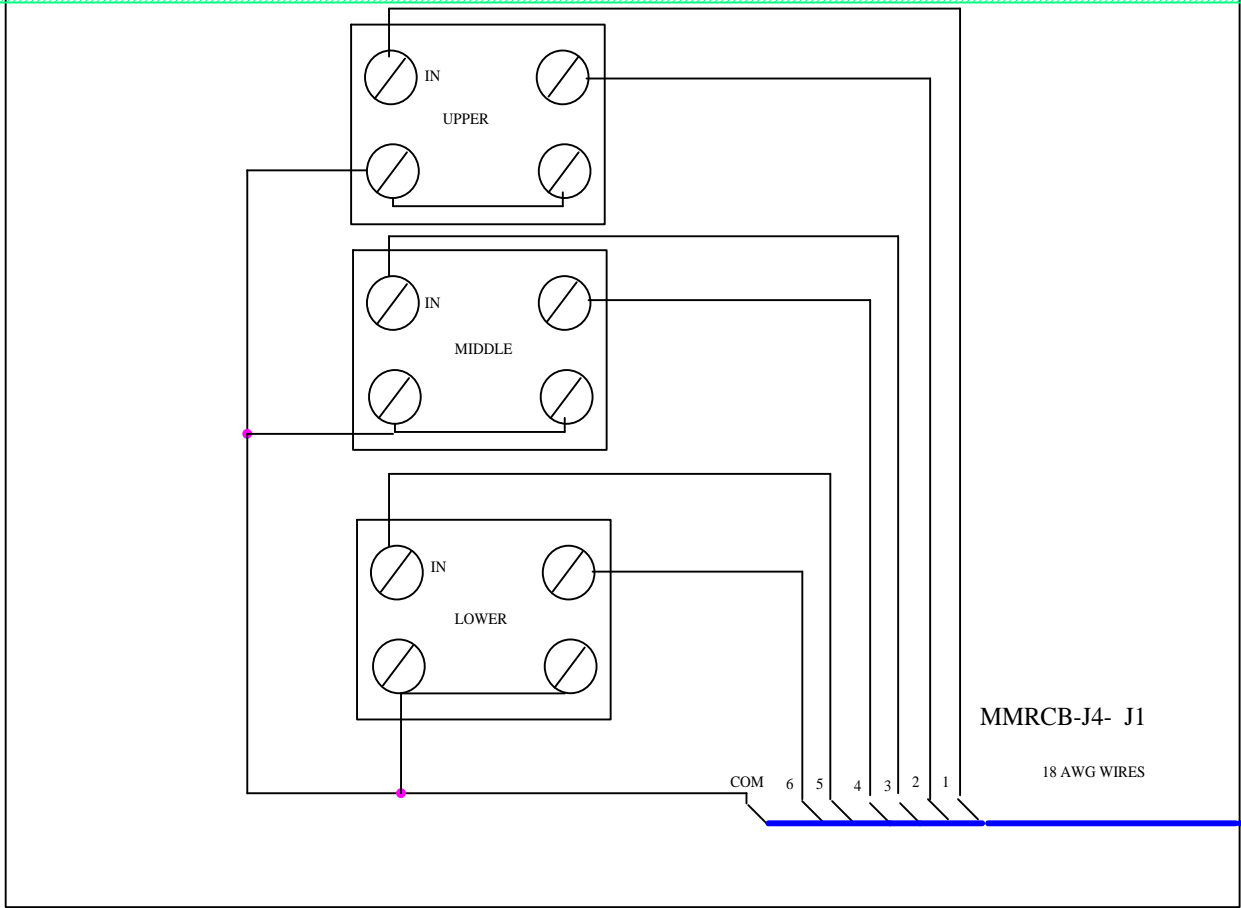
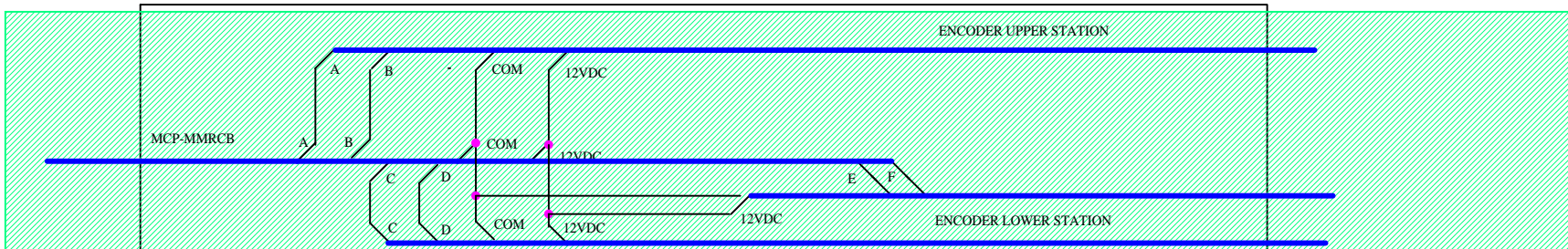

CRITTENDEN CONVERSION CORPORATION		
Title BRIDGE GUIDE 2003		
Size A	Document Number MANUAL MOVE REMOTE CONTROL BOX	Rev A
Date:	Friday, November 14, 2003	Sheet 4 of 10

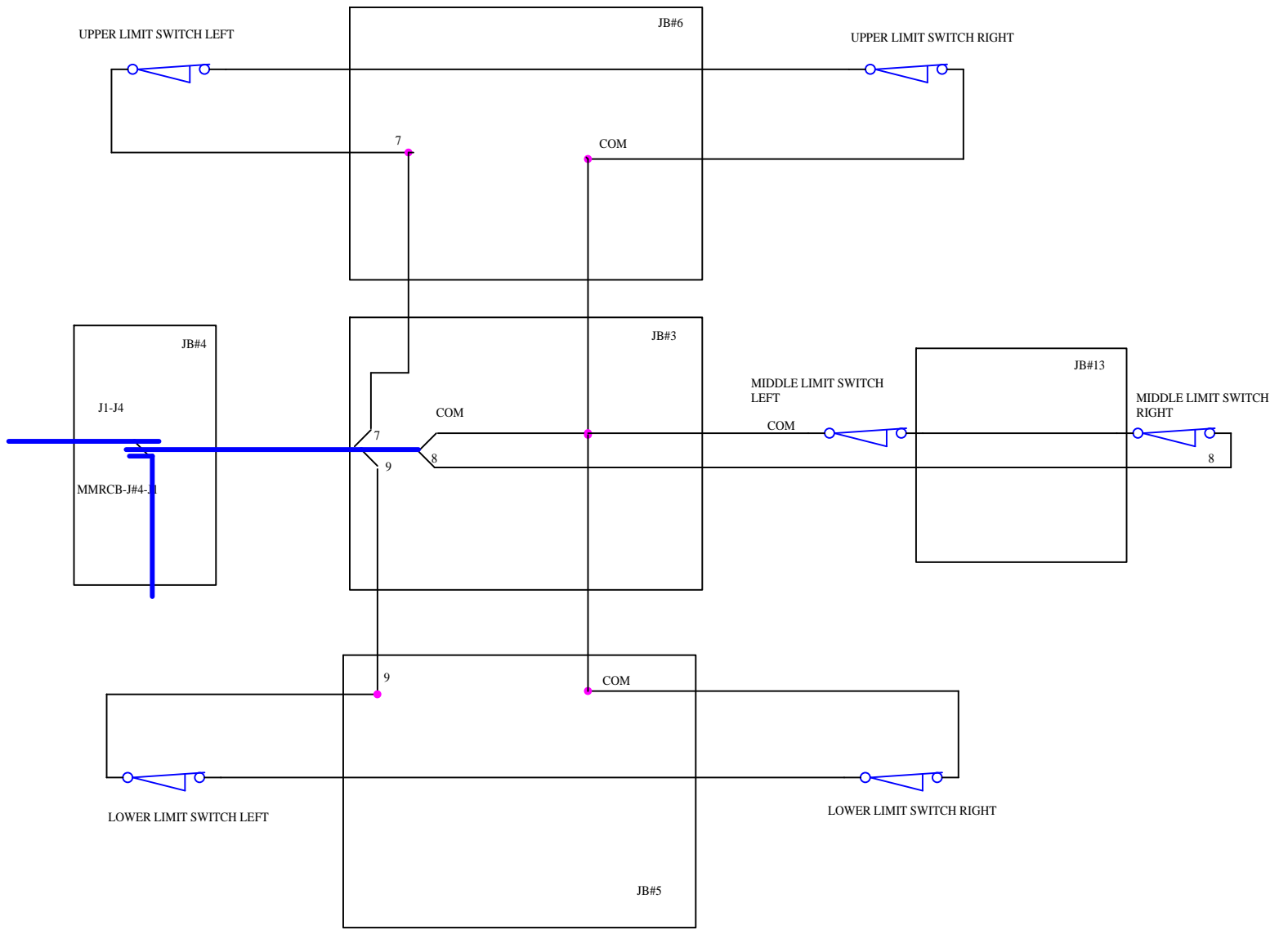

CRITTENDEN CONVERSION CORPORATION		
Title BRIDGE GUIDE 2003		
Size A	Document Number JUNCTION BOX#3#13	Rev A
Date:	Friday, November 14, 2003	Sheet 5 of 10

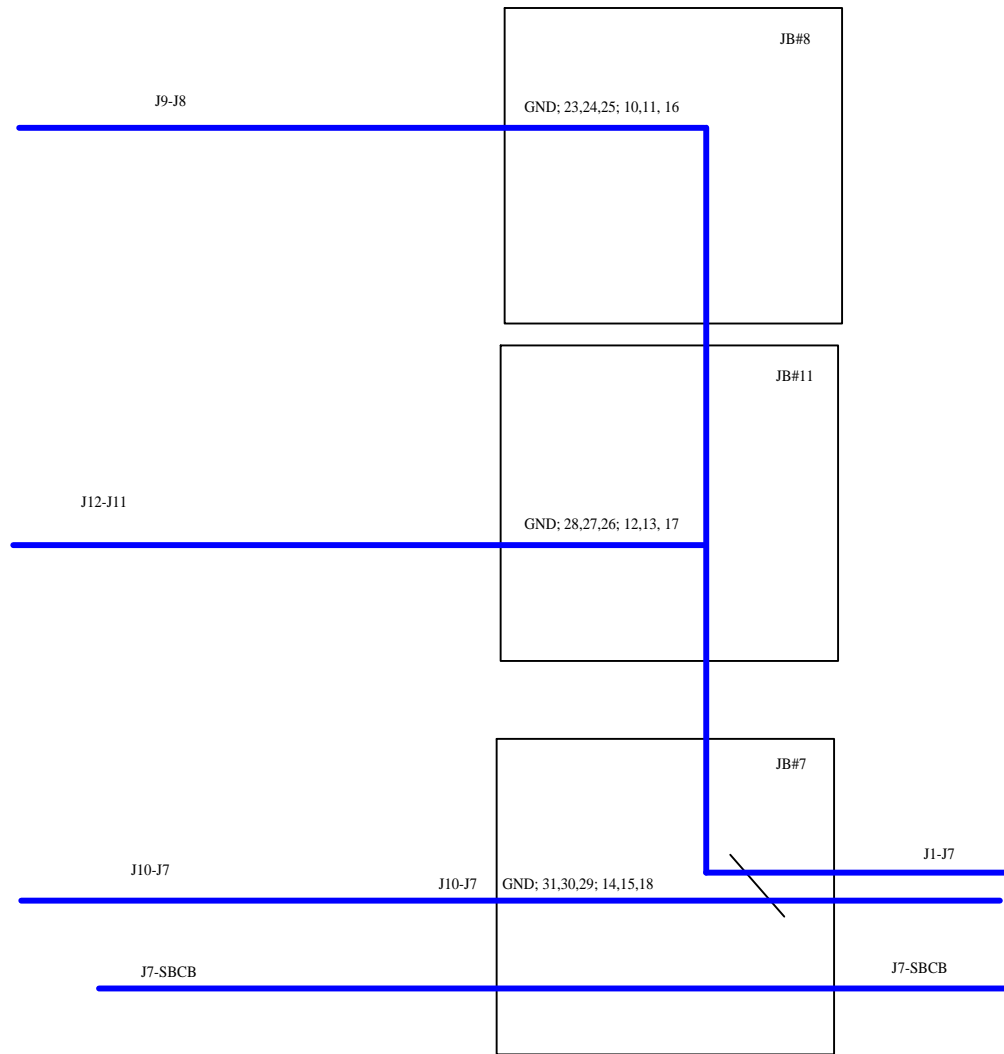

CRITTENDEN CONVERSION CORPORATION		
Title BRIDGE GUIDE 2003		
Size A	Document Number JUNCTION BOX#7	Rev A
Date:	Friday, November 14, 2003	Sheet 6 of 10

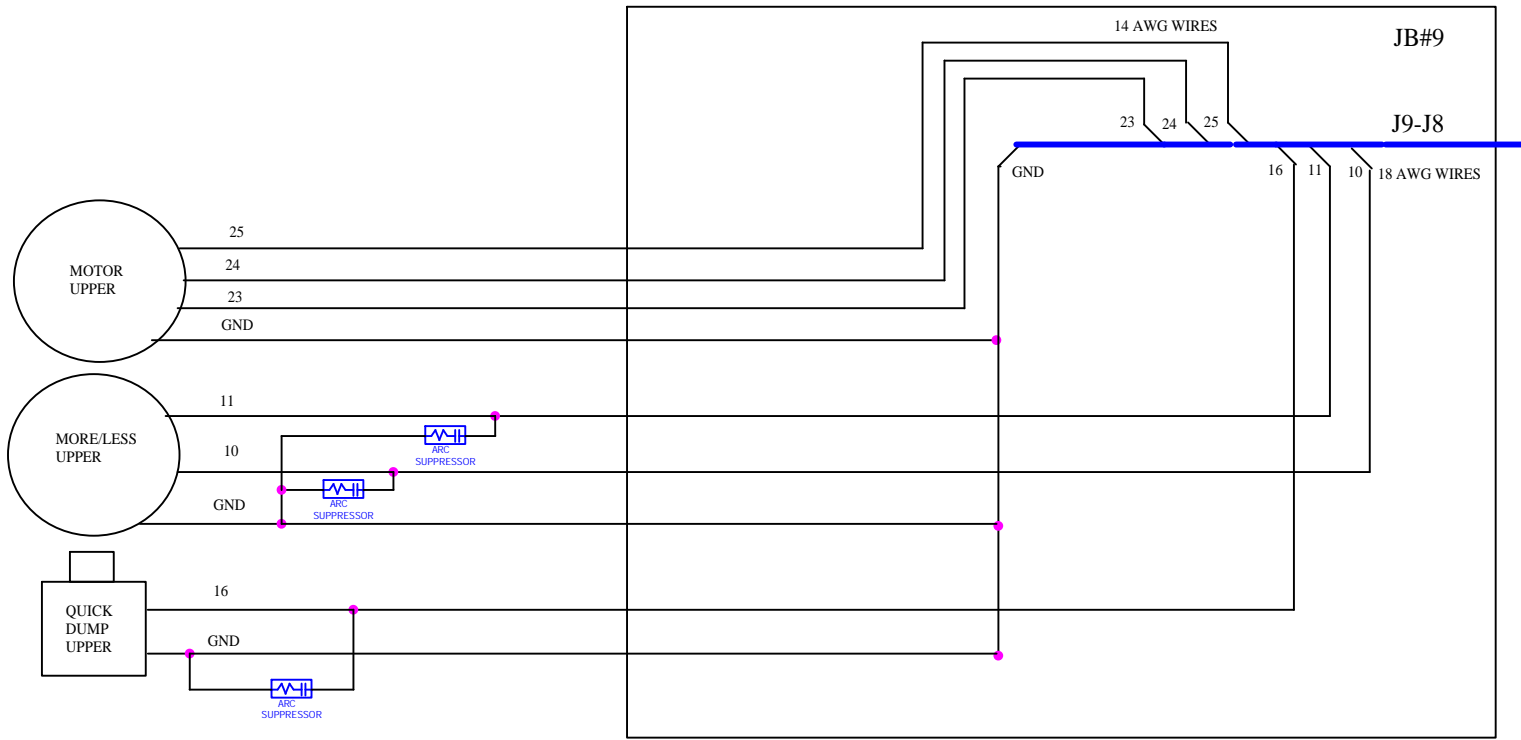

CRITTENDEN CONVERSION CORPORATION		
Title BRIDGE GUIDE 2003		
Size A	Document Number JUNCTION BOX#9	Rev A
Date:	Wednesday, February 04, 2004	Sheet 7 of 10

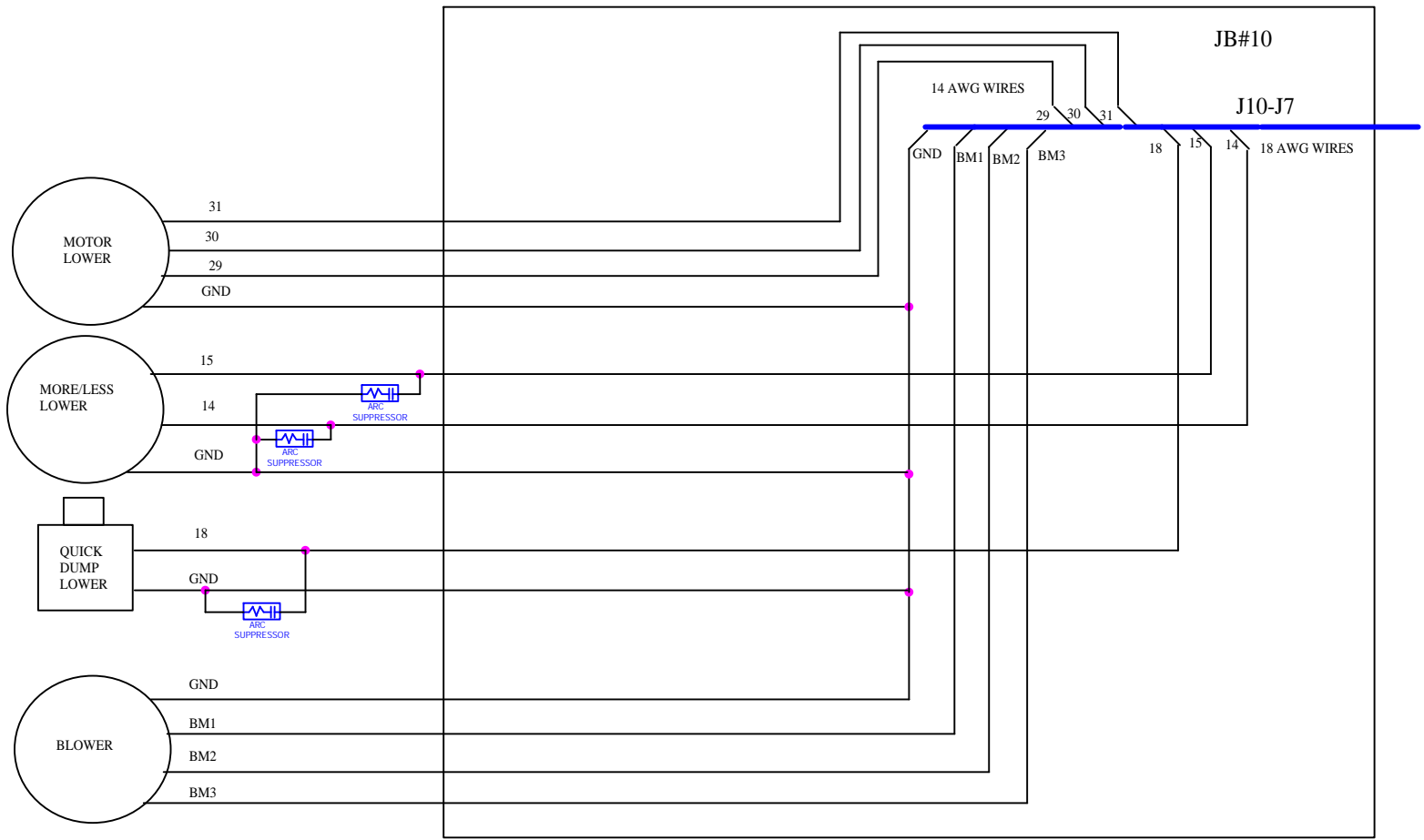

CRITTENDEN CONVERSION CORPORATION		
Title BRIDGE GUIDE 2003		
Size A	Document Number JUNCTION BOX#10	Rev A
Date:	Wednesday, February 04, 2004	Sheet 8 of 10

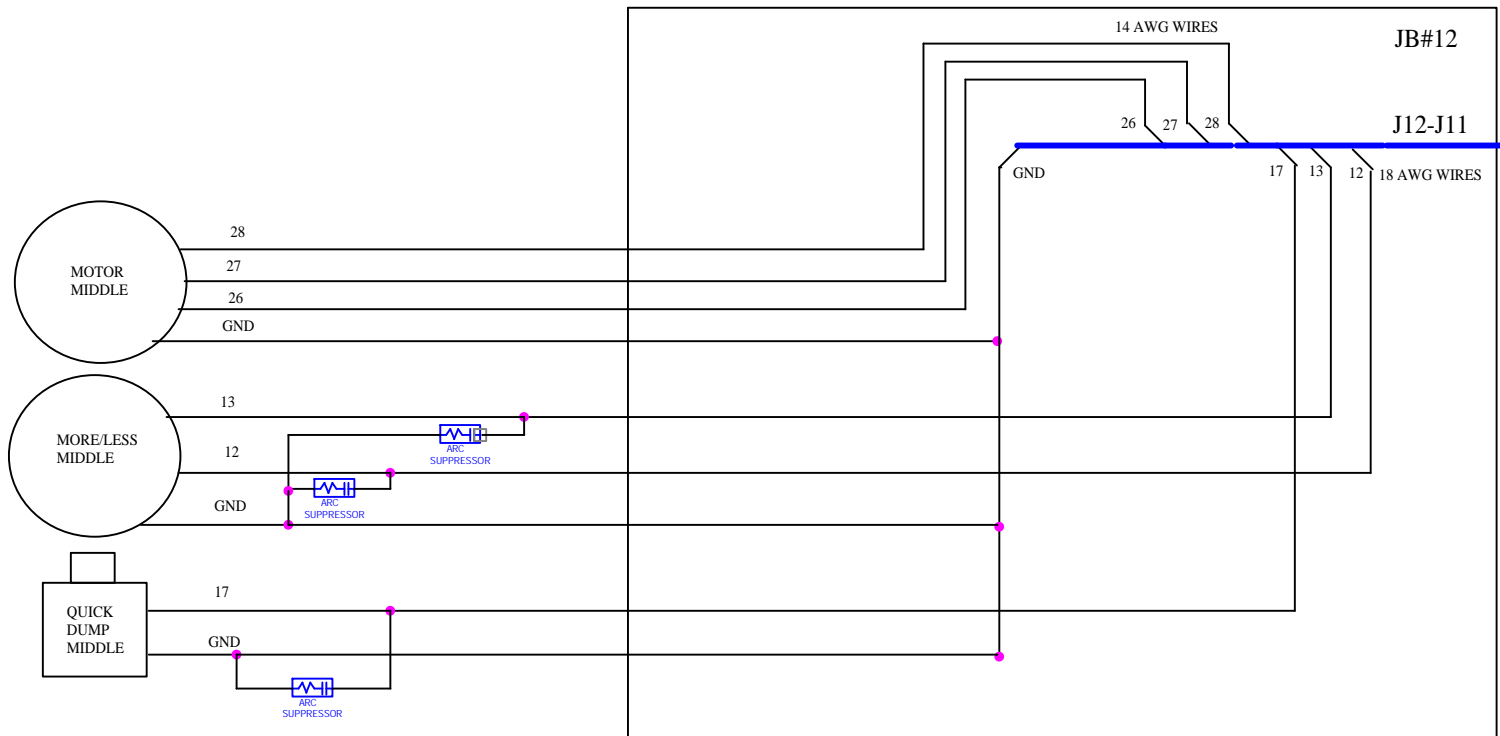

CRITTENDEN CONVERSION CORPORATION		
Title BRIDGE GUIDE 2003		
Size A	Document Number JUNCTION BOX#12	Rev A
Date:	Wednesday, February 04, 2004	Sheet 9 of 10

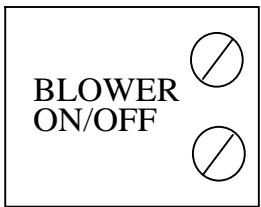

19
110

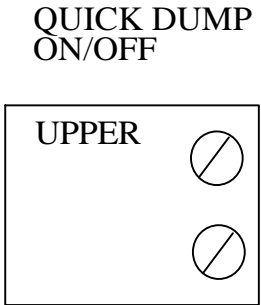

16
110

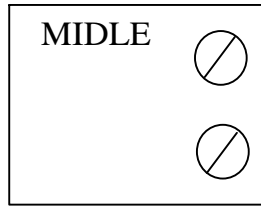

17
110

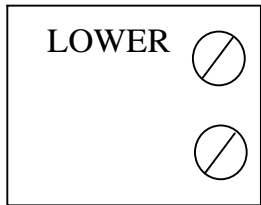

18
110

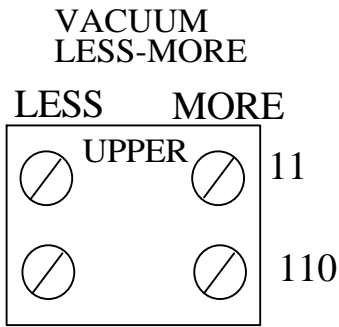

10
110

11
110

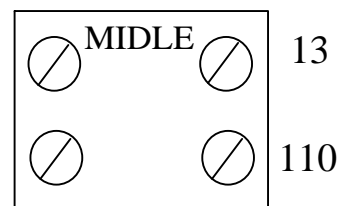

12
110

13
110

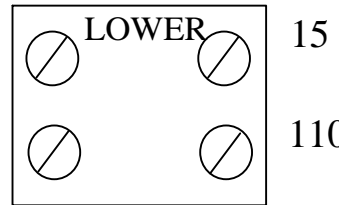

14
110

15
110

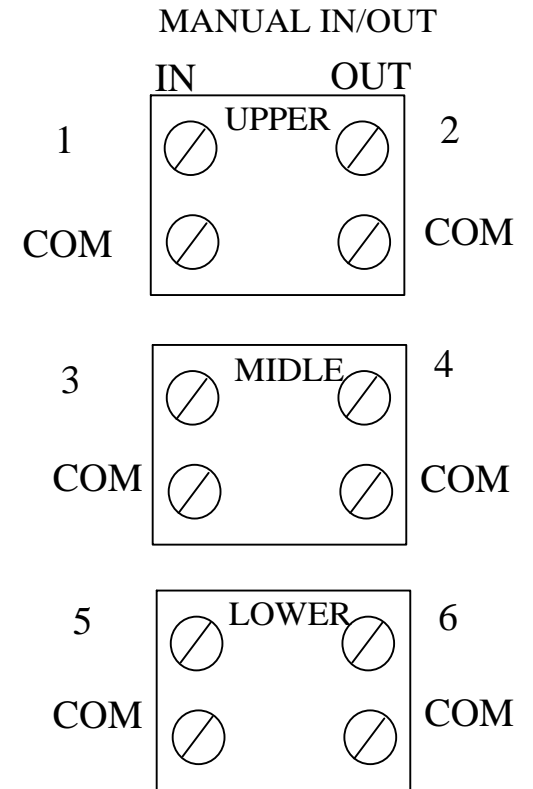
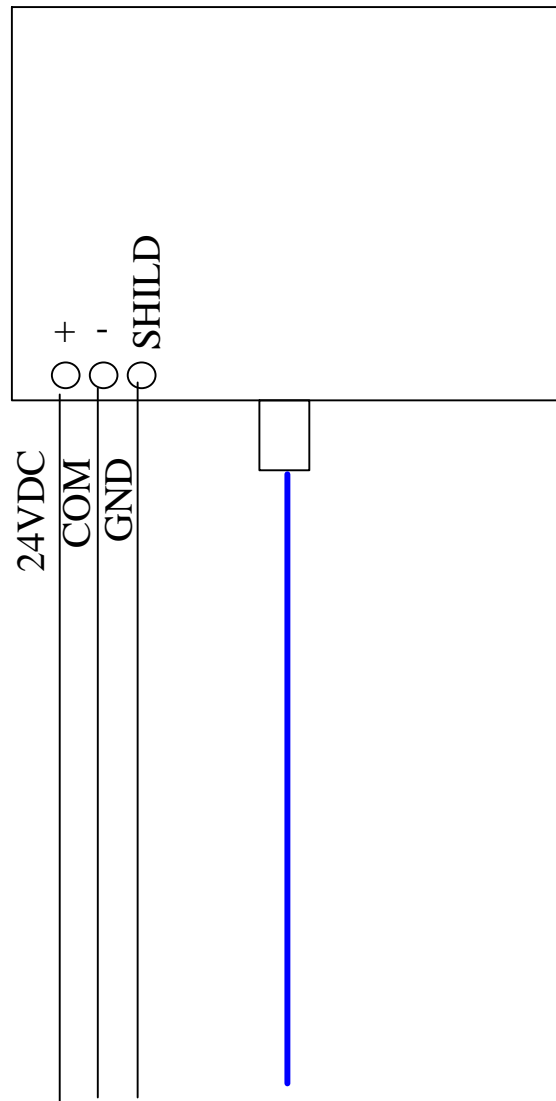

CRITTENDEN CONVERSION CORPORATION		
Title BG3 CONTROL PANEL FRONT INSIDE WIRING		
Size A	Document Number BG2003_3PanelWiring	Rev A
Date:	Friday, November 14, 2003	Sheet 10 of 10

16.0 TROUBLESHOOTING

To aid in troubleshooting, Parameters 50 through 60 can be accessed without entering the PASSWORD. Simply press the **Mode** button twice to “skip” over the PASSWORD prompt, and “P50” will be displayed to indicate that the parameter menu has been entered and Parameter 50 (FAULT HISTORY) can be viewed. The **▲** and **▼** buttons can then be used to scroll from Parameter 50 to Parameter 60. Once the desired parameter is found, press the **Mode** button to view its “contents”. When finished, press **Mode** to exit the parameter menu. An example is shown below:

Press **Mode** once

Display reads "00"

Upper right decimal point blinks

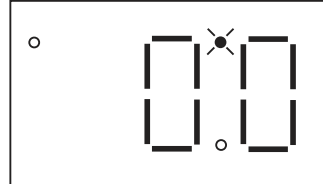

Press **Mode** again

Display reads "P50" (FAULT HISTORY)



Use **▲** and **▼** to scroll to the desired parameter number

(In this example Parameter 54 has been selected, which is MOTOR LOAD)

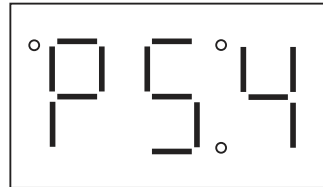

Press **Mode** to view parameter contents (77 = 77% LOAD)

Upper right decimal point blinks

Press **Mode** again to exit

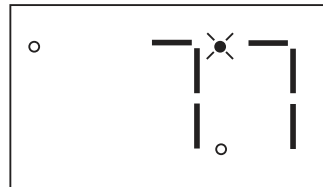

In the example above, Parameter 54 - MOTOR LOAD is being viewed. The “77” in the example indicates that the load on the motor is 77% of the output current rating of the drive.

The table below lists the fault conditions that will cause the drive to shut down, as well as some possible causes. Please contact the factory for more information on troubleshooting faults.

FAULT MESSAGES	
FAULT	DESCRIPTION & POSSIBLE CAUSES
AF	High Temp. Fault: Ambient temperature is too high; Cooling fan has failed (if equipped).
CF	Control Fault: A blank EPM, or an EPM with corrupted data has been installed. Perform a factory reset using Parameter 48 - PROGRAM SELECTION.
cF	Incompatibility Fault: An EPM with an incompatible parameter version has been installed. Either remove the EPM or perform a factory reset (Parameter 48) to change the parameter version of the EPM to match the parameter version of the drive.
dF	Dynamic Braking Fault: The drive has sensed that the dynamic braking resistors are overheating and shuts down to protect the resistors.
EF	External Fault: One of the TB-13 terminals is set as an External Fault input and that terminal is open with respect to TB-11. Refer to Parameters 10, 11 and 12.
GF	Data Fault: User data and OEM defaults in the EPM are corrupted.
HF	High DC Bus Voltage Fault: Line voltage is too high; Deceleration rate is too fast; Overhauling load. For fast deceleration or overhauling loads, dynamic braking may be required.
JF	Remote Keypad Fault: The communication link between the drive and the optional Remote Keypad has been lost. Check for proper wiring and/or noise.
LF	Low DC Bus Voltage Fault: Line voltage is too low.
OF	Output Transistor Fault: Phase to phase or phase to ground short circuit on the output; Boost settings are too high; Acceleration rate is too fast; Failed output transistor.
PF	Current Overload Fault: VFD is undersized for the application; Mechanical problem with the driven equipment.
UF	Start Fault: Start command was present when the drive was powered up. Must wait 2 seconds after power-up to apply Start command if START METHOD is set to NORMAL.
F1	EPM Fault: The EPM is missing or damaged.
FC, F2 - F9, Fo	Internal Faults: The control board has sensed a problem - consult factory.

To clear a fault, issue a STOP command on the terminal strip. The fault will only clear if the condition that caused the fault has passed. For example, if the drive trips on a LOW DC BUS VOLTAGE FAULT (LF) due to low input voltage, the fault cannot be cleared until the input voltage returns to a normal level.

If the drive is programmed to automatically restart after a fault (see Parameter 03), the drive will attempt to restart three times after a fault (the drive will not restart after CF, cF, GF, FC, F1, F2-F9, or Fo faults). If all three restart attempts are unsuccessful, the drive will trip into FAULT LOCKOUT (LC), which requires a manual reset as described above.

17.0 SCL/SCM DISPLAY MESSAGES

The following describes the various displays and messages that can appear on the SCL/SCM drive.

17.1 SPEED DISPLAY

If the drive is in a STOP state (indicated by "- -" on the display), and the commanded speed is changed, the display will show the commanded speed, and the upper left decimal point will turn on solid. About five seconds after a change is made, the display will begin to alternate between the commanded speed value and the "- -" display. If the **Mode** button is pressed, the display will stop alternating and show the "- -" display only.

When the drive is given a START command, the displayed speed will start increasing as the drive accelerates up to the commanded speed. If the commanded speed is changed while the drive is running, the display will show the commanded speed rather than the actual speed, until the actual speed reaches the commanded speed.

If the commanded speed is changed faster than the drive can accelerate or decelerate, the upper left decimal point will blink to indicate that the the drive is accelerating or decelerating to the new speed. Once the actual speed reaches the commanded speed, the upper left decimal point will turn on solid for 5 seconds and then turn off to indicate that the commanded speed has been reached, and that the display is now showing the actual speed.

17.2 CHANGING THE SPEED REFERENCE SOURCE

When the speed source is changed while the drive is running, the display will flash the message for the new speed source to indicate that the new speed source is active. Also, if the drive is being controlled from a speed source other than the ▲ and ▼ buttons (0-10 VDC, 4-20 mA, etc), and one of the ▲ or ▼ buttons is pressed, the display will flash the present speed source message to indicate that the ▲ and ▼ buttons are invalid.

Example 1: The drive is running and the present speed source is the keypad. TB-13A is programmed to select a 4-20 mA signal as the speed source. When TB-13A is closed to TB-11, the display will flash "EI" to indicate that the speed source has changed to the 4-20 mA signal. If the contact between TB-13A and TB-11 is opened, the display will flash "CP" to indicate that the speed source has changed back to the ▲ and ▼ buttons.

Example 2: The speed source is a 0-10 VDC signal. If the ▲ or ▼ button is pushed, the display will flash "EU" to indicate that the present speed source is the 0-10 VDC signal and that the ▲ and ▼ buttons are invalid.

Refer to the table below for the possible speed reference source displays:

SPEED SOURCE DISPLAYS	
DISPLAY	DESCRIPTION
CP	CONTROL PAD: Speed is set using the ▲ and ▼ buttons on the front of the drive.
EI	EXTERNAL CURRENT: Speed is controlled by a 4-20 mA signal wired to TB-25 and TB-2.
EU	EXTERNAL VOLTAGE: Speed is controlled by a 0-10 VDC signal wired to TB-5 and TB-2.
JG	JOG: The drive is in Jog mode, and the speed is set by Preset Speed #2 (Parameter 32).
OP	MOP (Motor Operated Pot): Contacts wired to TB-13B and TB-13C are used to increase and decrease the drive speed.
Pr1 - Pr7	PRESET SPEEDS #1-7: Speed is set by the indicated Preset Speed (Parameters 31-37).

NOTE: The speed source displays will flash when the speed reference source is changed while the drive is running to indicate that the new speed reference source is active.

17.3 STATUS AND WARNING MESSAGES

STATUS AND WARNING MESSAGES	
DISPLAY	DESCRIPTION
br	DC BRAKING: The DC braking circuit is activated.
cE	"cE" will be displayed if an EPM with a different parameter version is installed and then an attempt is made to change parameter settings without performing the TRANSLATE function. Refer to PROGRAM SELECTION (Parameter 48).
CL	CURRENT LIMIT: The output current has exceeded the CURRENT LIMIT setting (Parameter 25) and the drive is reducing the output frequency to reduce the output current. If the drive remains in CURRENT LIMIT for too long, it can trip into a CURRENT OVERLOAD fault (PF).
Er	ERROR: Invalid data has been entered or an invalid command was attempted.
GE	"GE" will be displayed if an attempt is made to change the OEM default settings when the drive is operating in the OEM mode (see Parameter 48).
GF	If "GF" is displayed when a RESET OEM is attempted, it indicates that the OEM defaults in the EPM are corrupted. If "GF" is displayed upon power-up, it indicates that the OEM defaults and the user settings in the EPM are corrupted. Refer to Section 13.2.
LC	FAULT LOCKOUT: The drive has failed three restart attempts and now requires manual reset.
SE	SERIAL: The optional remote keypad is active as the user interface instead of the buttons on the front of the drive. See Parameter 14 - CONTROL.
SP	START PENDING: "SP" blinks during the interval between restart attempts.
✕ ✕	DECEL OVERRIDE (both upper decimal points blinking): The drive has stopped decelerating to avoid tripping into an HF fault due to regenerative energy from the motor.